



III

THE TRANSIT SANCTUARY

SYSTEM AND FRAGMENT



SPATIAL SEQUENCE OVERVIEW

52

- ① ENTRANCE
- ② PART 1
THE THRESHOLD CHAMBERS
- ③ PART 2
THE HALL OF EQUILIBRIUM
- ④ PART 3
THE ATRIUM OF PATHS
- ⑤ PART 4
THE CHAMBER OF LOOPS
- ⑥ PART 5
THE CORRIDOR OF RETURN
- ⑦ EXIT

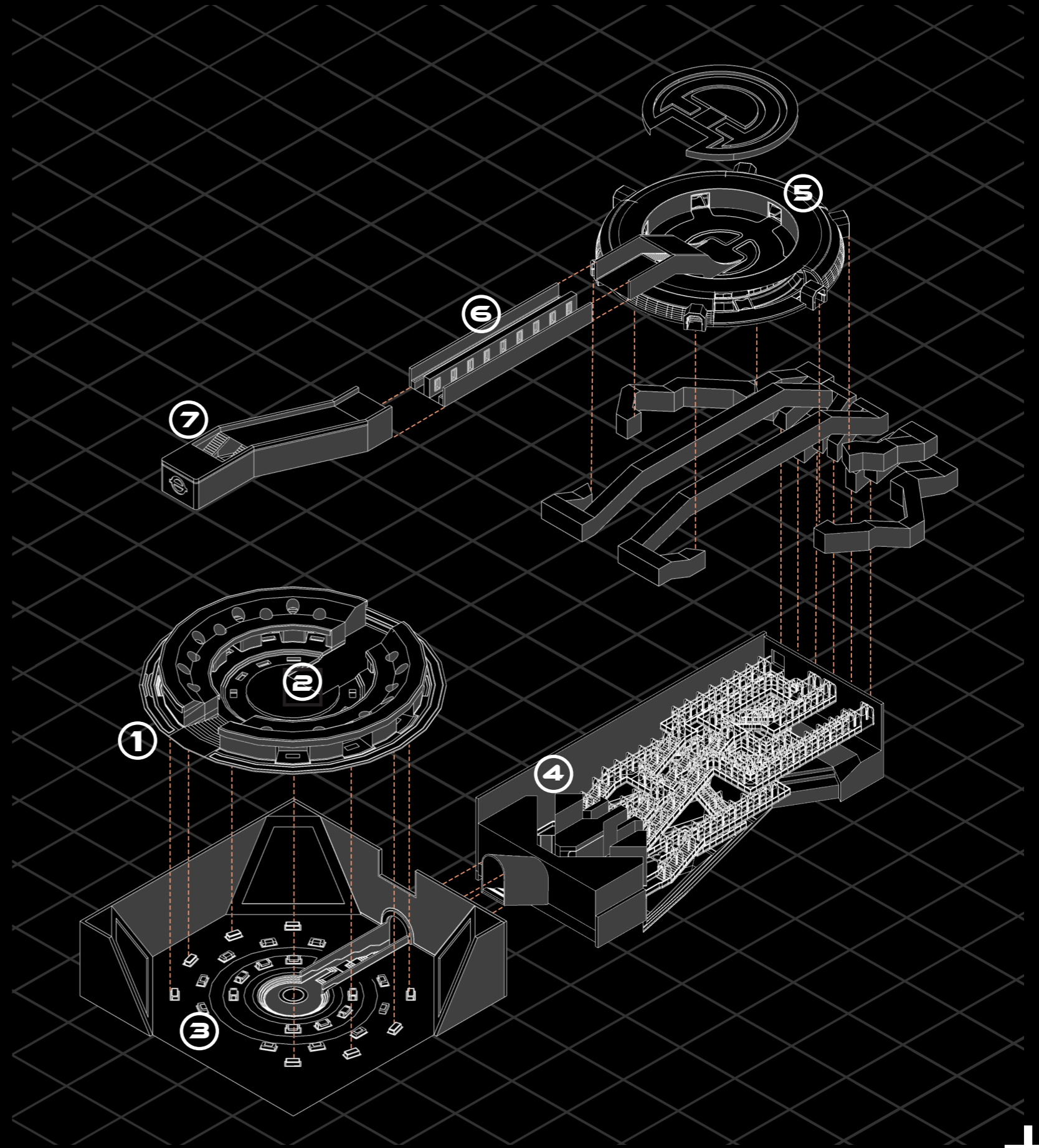

SECTION PERSPECTIVE

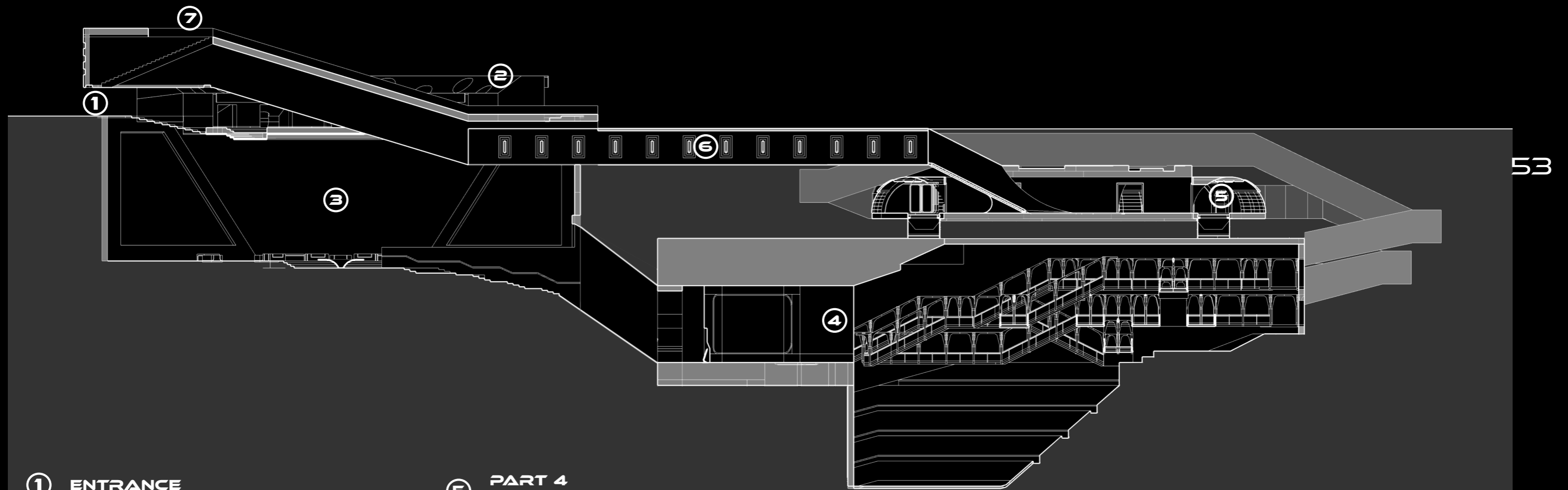

① ENTRANCE

② PART 1
THE THRESHOLD CHAMBERS

③ PART 2
THE HALL OF EQUILIBRIUM

④ PART 3
THE ATRIUM OF PATHS

⑤ PART 4
THE CHAMBER OF LOOPS

⑥ PART 5
THE CORRIDOR OF RETURN

⑦ EXIT

SPATIAL SYSTEM AND PROCESS DIAGRAM

54

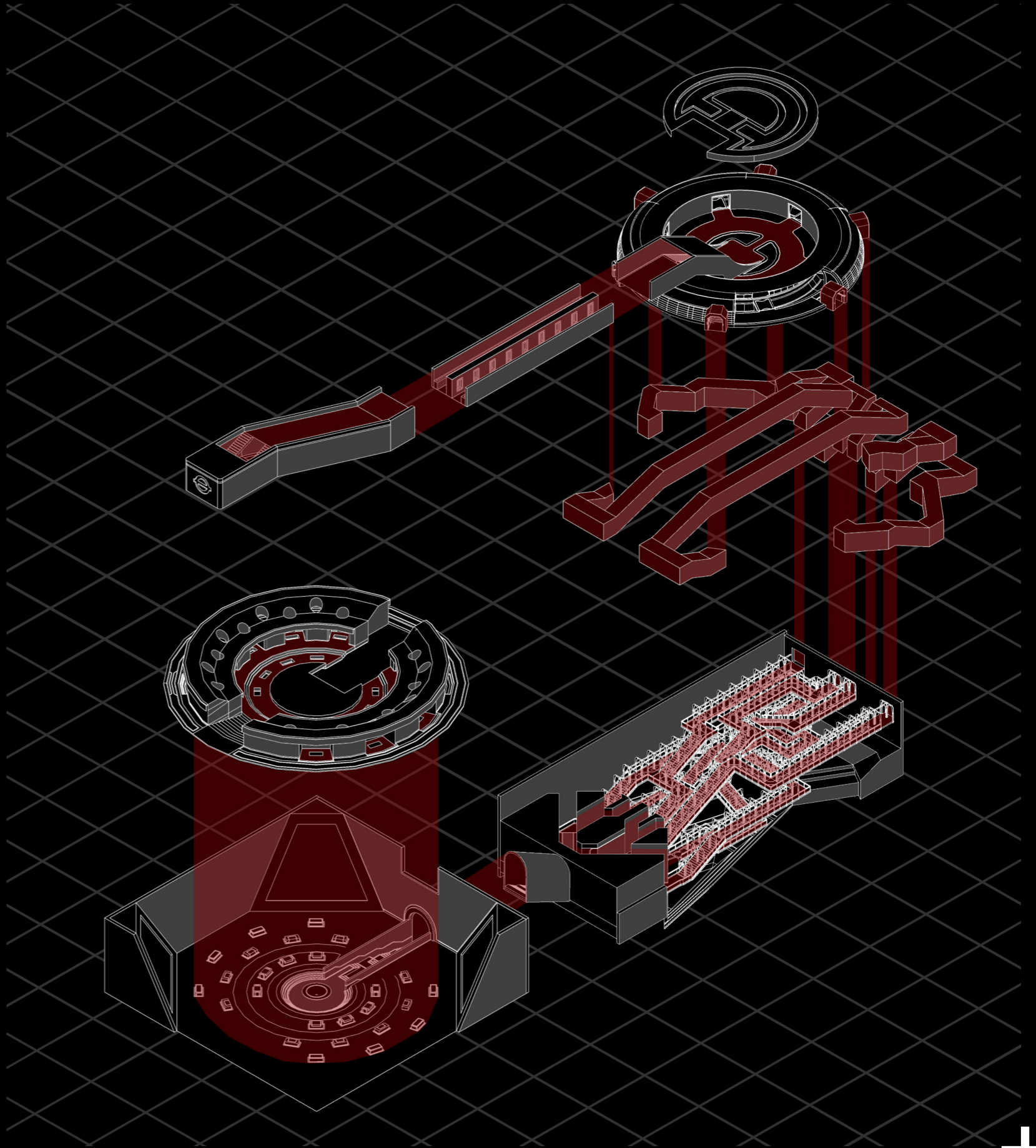
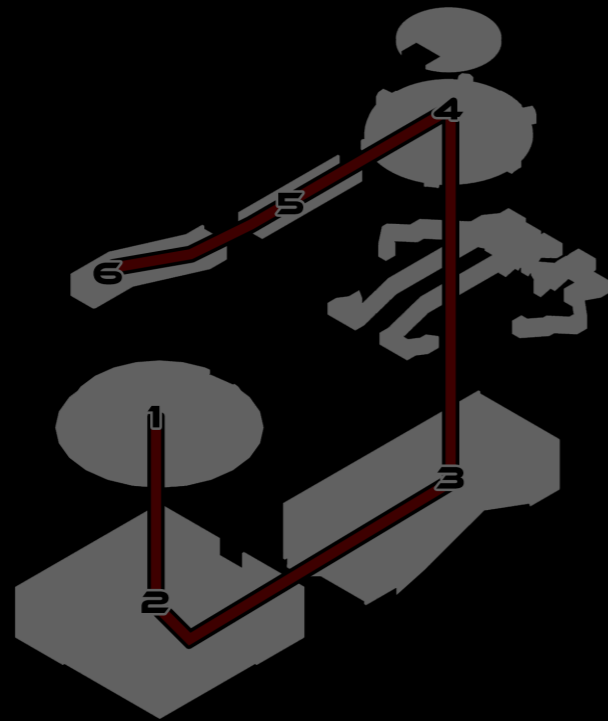

PART 1

THE THRESHOLD

CHAMBERS

THE RITUAL OPENS WITH SOLITUDE AND SUSTENANCE. EACH PARTICIPANT SITS BEFORE A SMALL PORTION OF FOOD – AN ORDINARY ACT STRIPPED OF ITS DAILY MEANING. HERE, EATING BECOMES A SYMBOLIC GESTURE OF READINESS, A MOMENT WHERE PERSONAL IDENTITY IS SUSPENDED AND THE SELF PREPARES TO DESCEND. AS THE STONE PLATFORM LOWERS, THE BOUNDARIES BETWEEN INDIVIDUALS FADE; THE ACT OF NOURISHMENT TURNS INTO COLLECTIVE SURRENDER. THE DESCENT IS NO LONGER PHYSICAL ALONE, BUT A QUIET PASSAGE FROM INDIVIDUALITY TO SHARED RHYTHM.

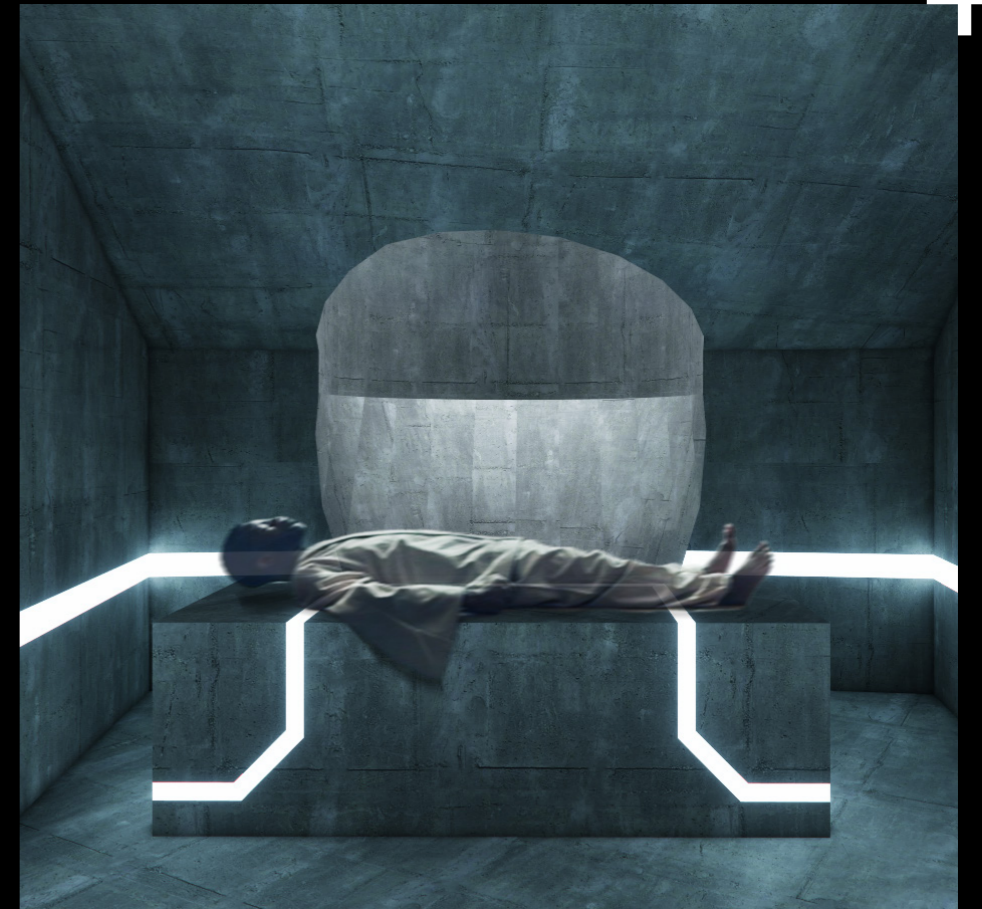

EXPLODED VIEW AND DETAILS

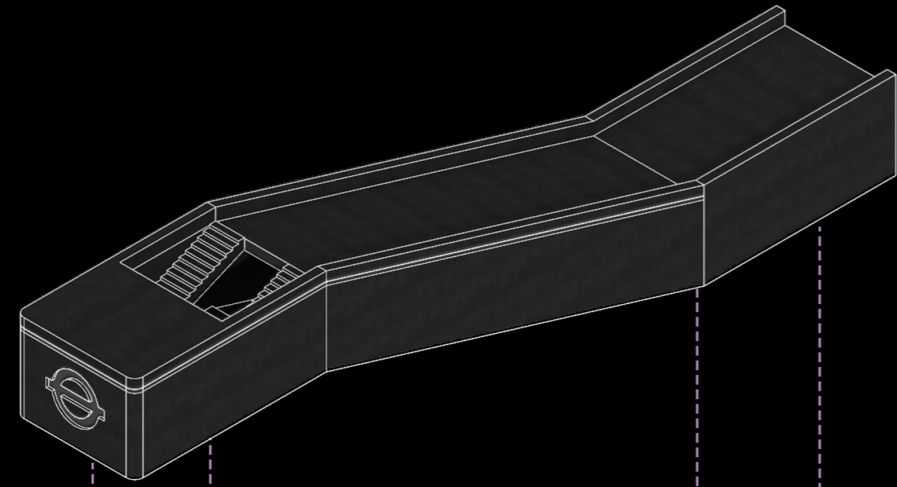

THE HIGH CHAMBER

THE LARGEST AND HIGHEST POSITION SPACE, LOCATED ON THE OUTSIDE, WITHDRAWN AND UNSEEN, WHERE SOLITUDE MARKS THE PRIVILEGE OF DETACHMENT

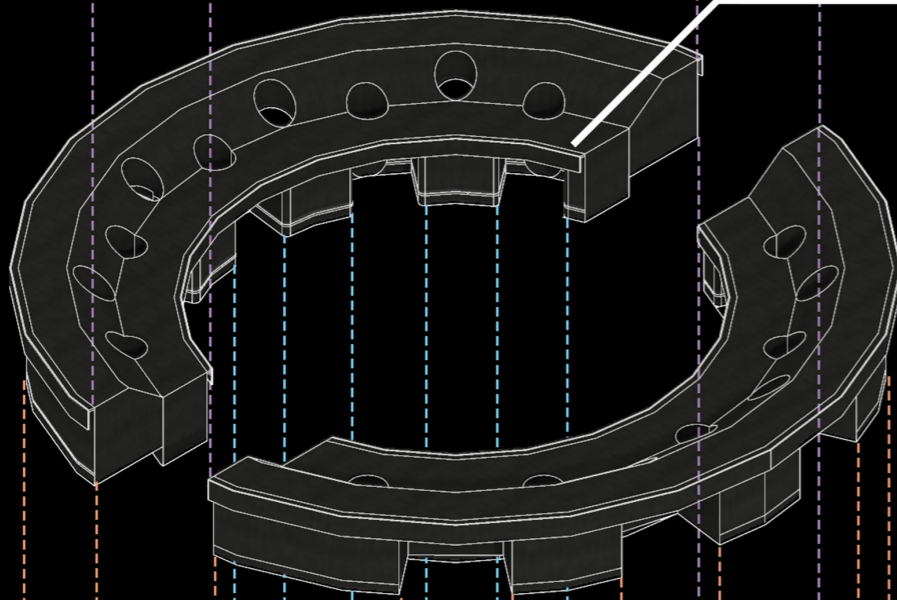
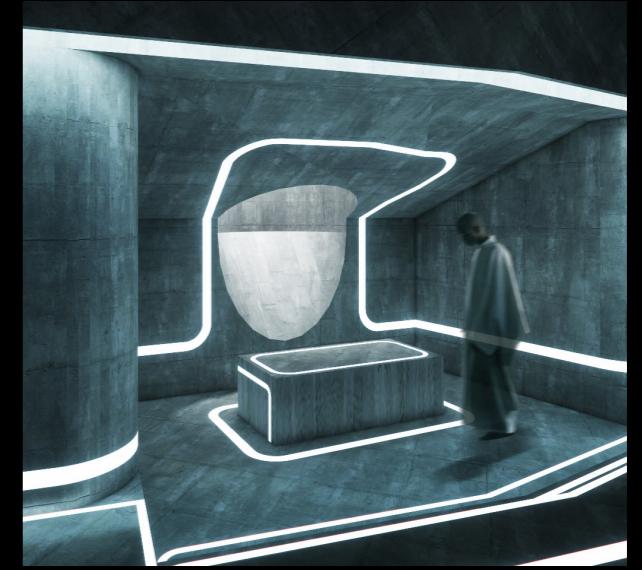
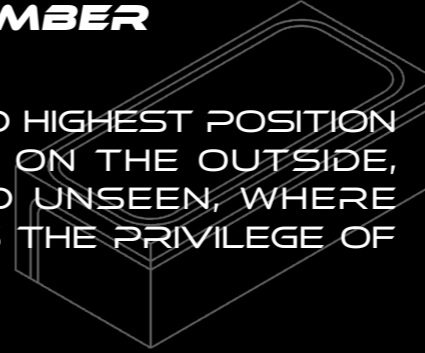

THE MIDDLE COURT

A SEPARATE SPACE, LOCATED ON THE INSIDE, OPEN TOWARD THE CROWD, WHERE VISIBILITY AND RESTRAINT COEXIST

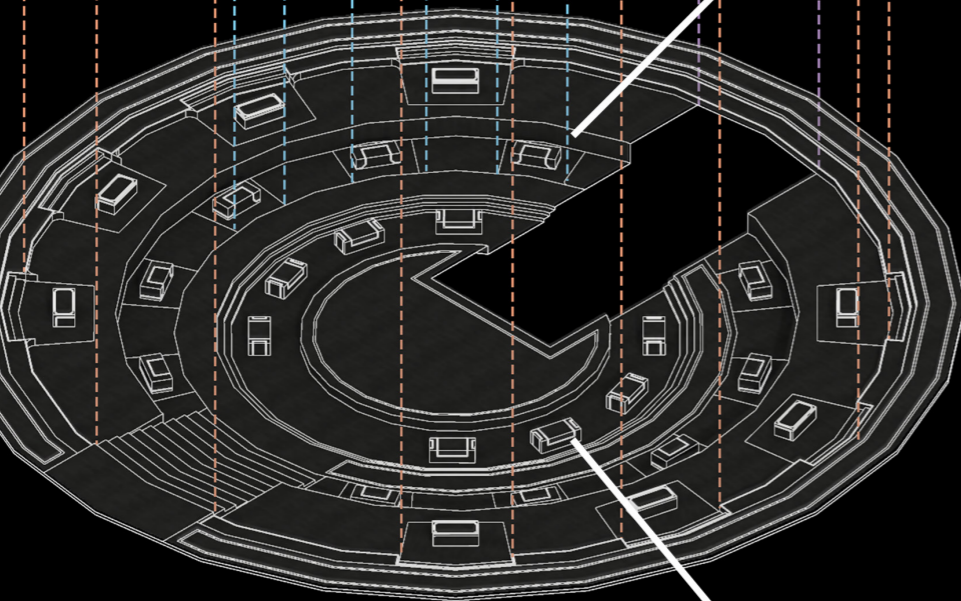
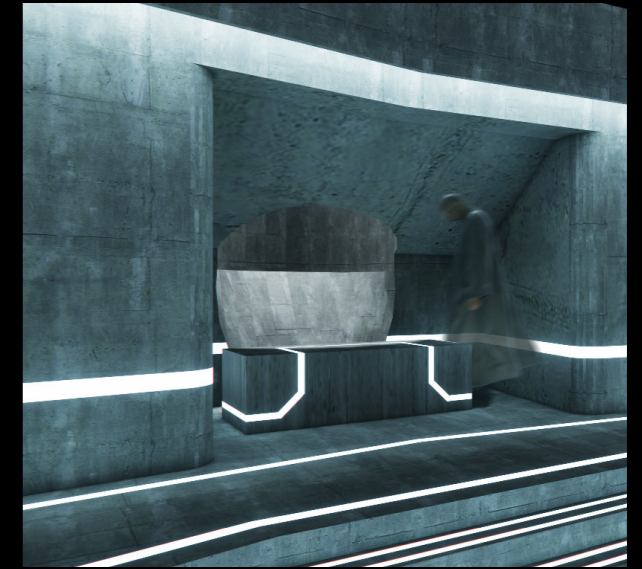

THE GROUND OF OFFERING

OPEN TO THE ELEMENTS, AT THE LOWEST PHYSICAL LOCATION, EXPOSED TO LIGHT AND AIR, WHERE THE SELF MERGES WITH THE COLLECTIVE





IDENTIFYING ELEMENTS OF LONDON UNDERGROUND STATIONS

THE LONDON UNDERGROUND HAS A LONG HISTORY AND IS CONSTANTLY UNDER CONSTRUCTION. THIS HAS LED TO THE RELIANCE ON THE BULLSEYE LOGO TO IDENTIFY SUBWAY STATION BUILDINGS.

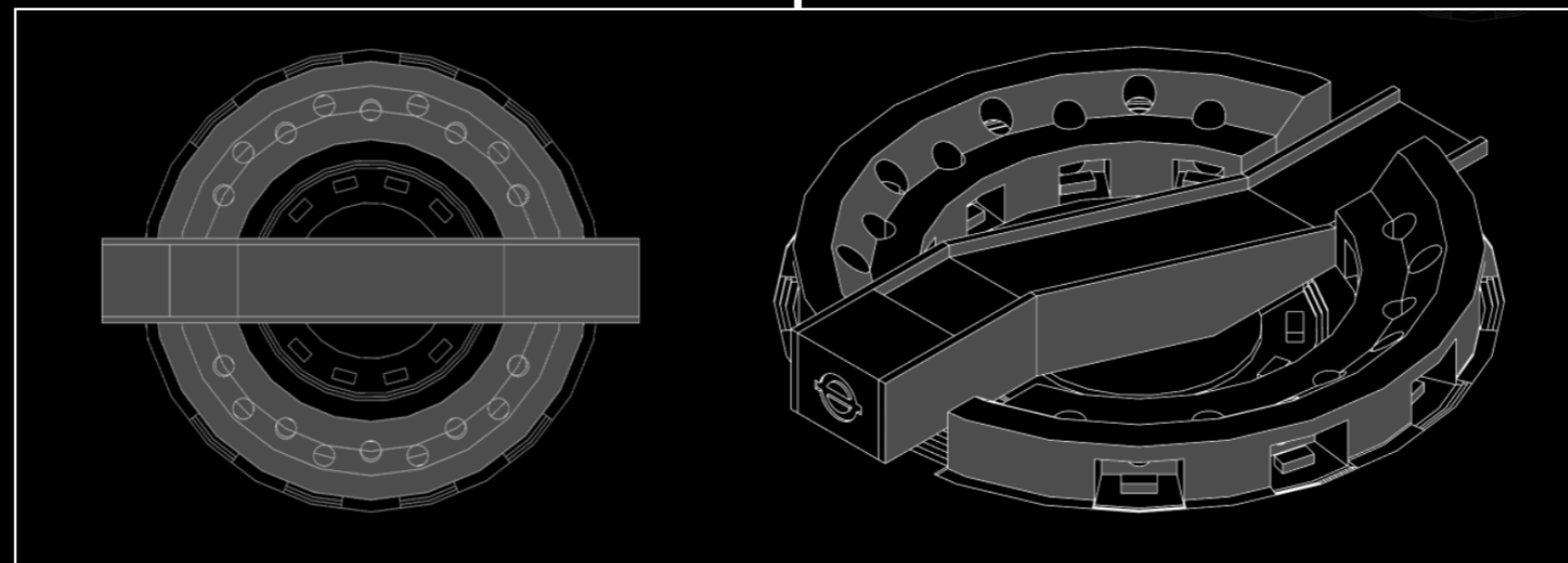

GROUND PART OF THE DESIGN

PART 2

THE HALL OF EQUILIBRIUM

WHEN THE DESCENT ENDS, SEPARATION GIVES WAY TO GATHERING. PARTICIPANTS STEP FROM THEIR INDIVIDUAL CHAMBERS INTO A CIRCULAR HALL WHERE ALL HIERARCHIES DISSOLVE. MOVEMENT BECOMES SYNCHRONIZED; EACH STEP ECHOES ANOTHER. IN THIS MOMENT, IDENTITY IS NO LONGER PERSONAL BUT RHYTHMIC – A PULSE SHARED BY MANY. THE CROWD FORMS A SINGLE BODY, GUIDED NOT BY COMMAND BUT BY TEMPO. WHAT WAS ONCE A COLLECTION OF INDIVIDUALS NOW BREATHES AS ONE.

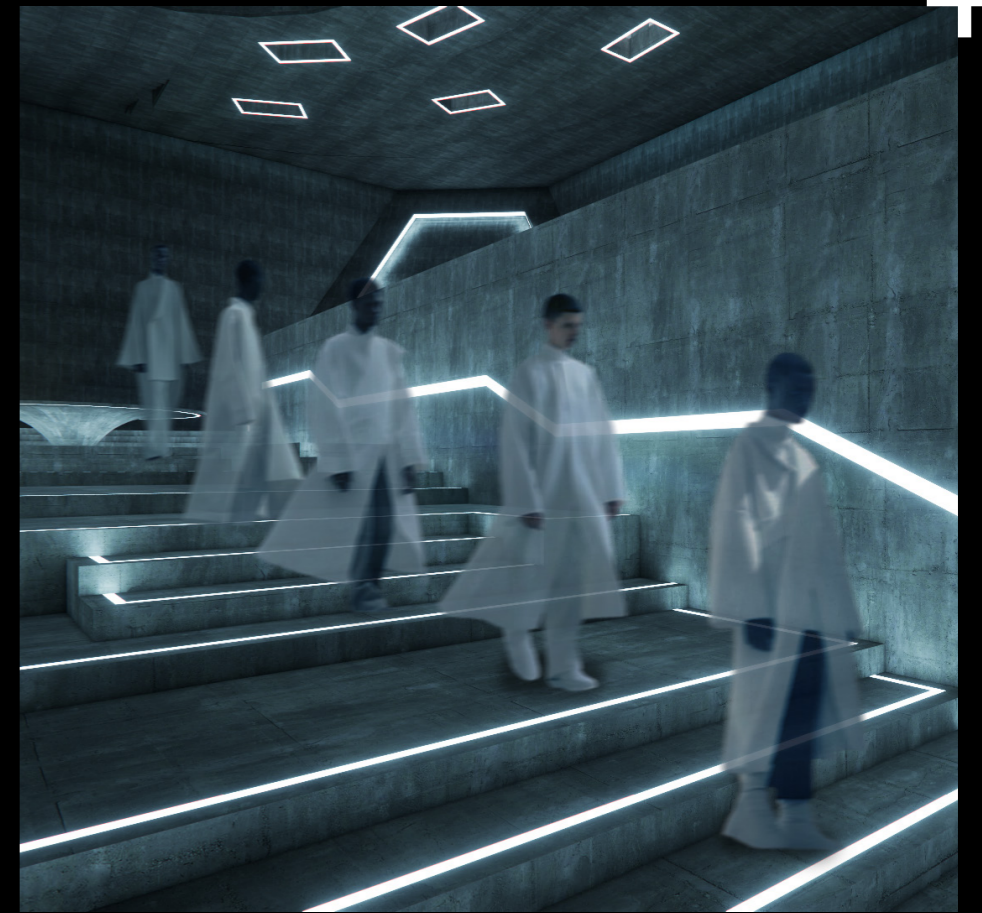

EXPLODED VIEW AND DETAILS

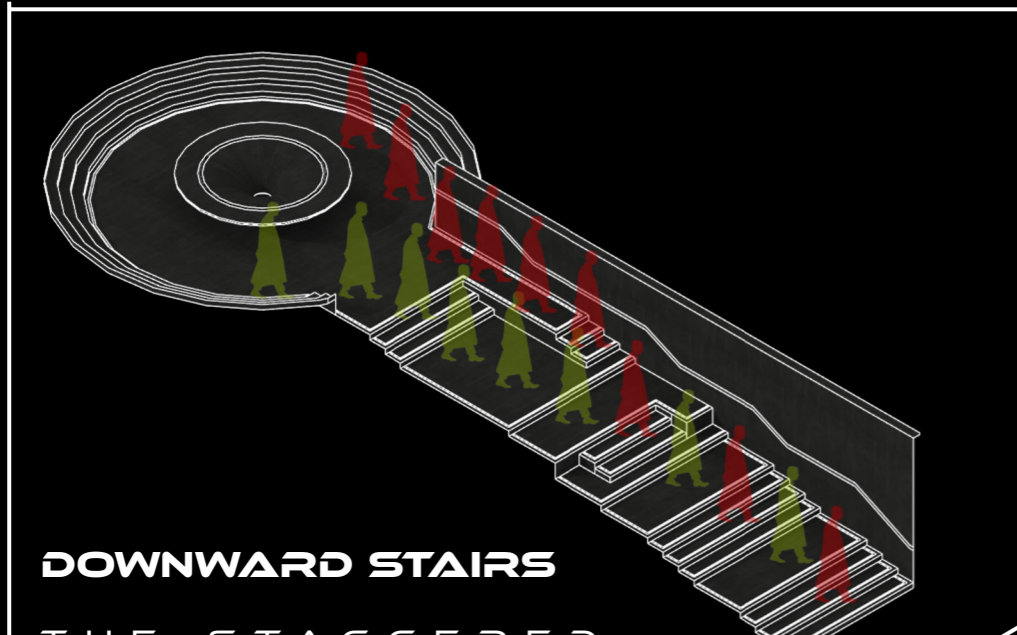

DOWNWARD STAIRS

THE STAGGERED, NARROWING STAIRCASES FACILITATE THE CONVERGENCE OF PEDESTRIAN TRAFFIC.

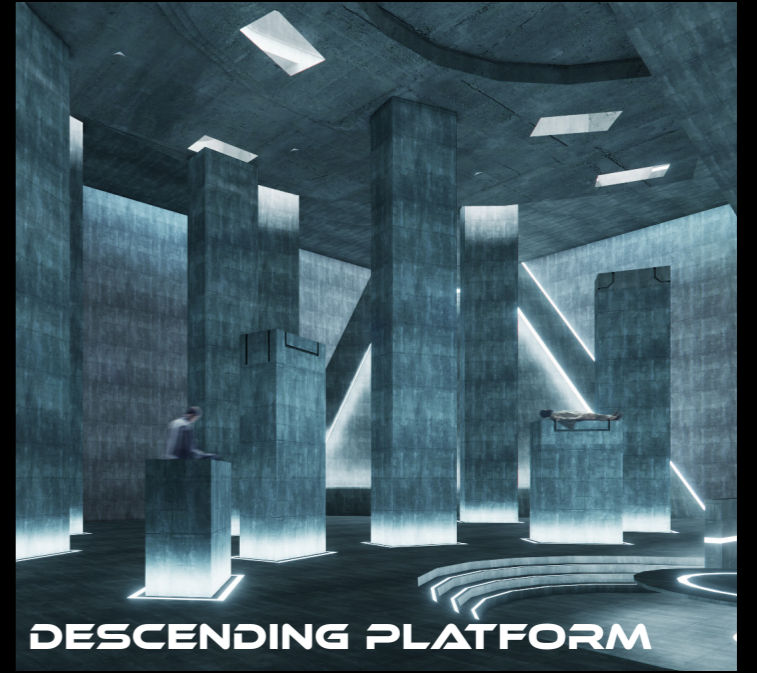
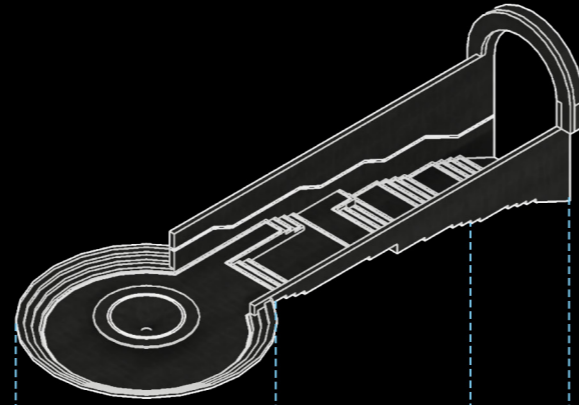

DESCENDING PLATFORM

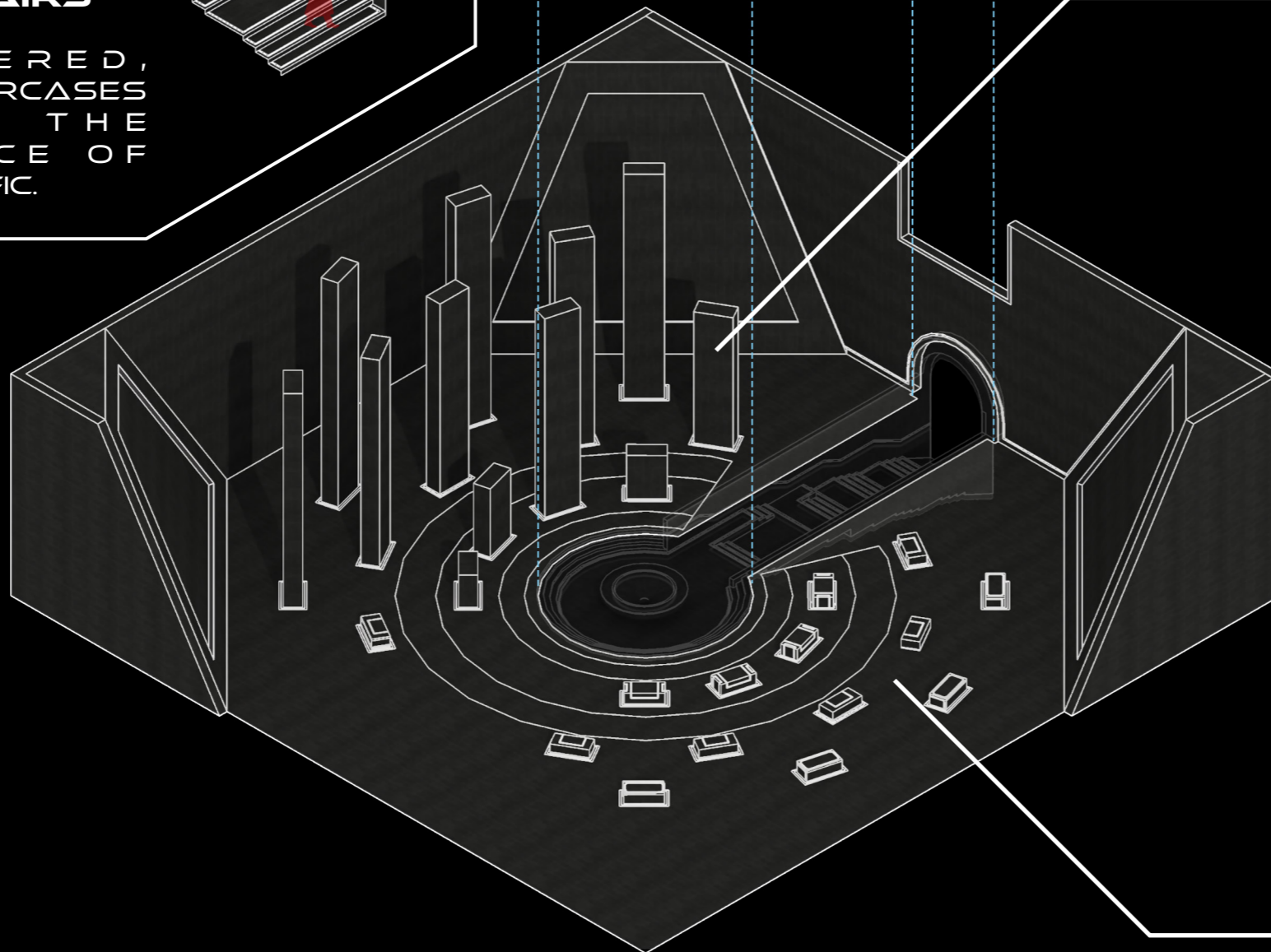

SPACE ENTRANCE

PARTICIPANTS ARE BROUGHT TO THE SAME SPACE AT THE SAME HEIGHT BY A PLATFORM THAT DESCENDS FROM THE GROUND.



AFTER DESCENT

PART 3

THE ATRIUM OF PATHS

FROM THE SHARED RHYTHM, DIFFERENCE BEGINS TO RISE AGAIN. WITHIN THE TALL ATRIUM, PATHS BRANCH IN MULTIPLE DIRECTIONS. BODIES SEPARATE, YET THEIR MOTION STILL FOLLOWS THE SAME UNDERLYING BEAT. CHOICE HERE IS NOT FREEDOM IN THE ABSOLUTE SENSE, BUT A VARIATION WITHIN RHYTHM, A NEGOTIATION BETWEEN INDIVIDUALITY AND ORDER. EACH ASCENT OR DESCENT BECOMES A MEASURE OF PERSONAL WILL WITHIN THE COLLECTIVE FLOW.



+ EXPLODED VIEW AND DETAILS +

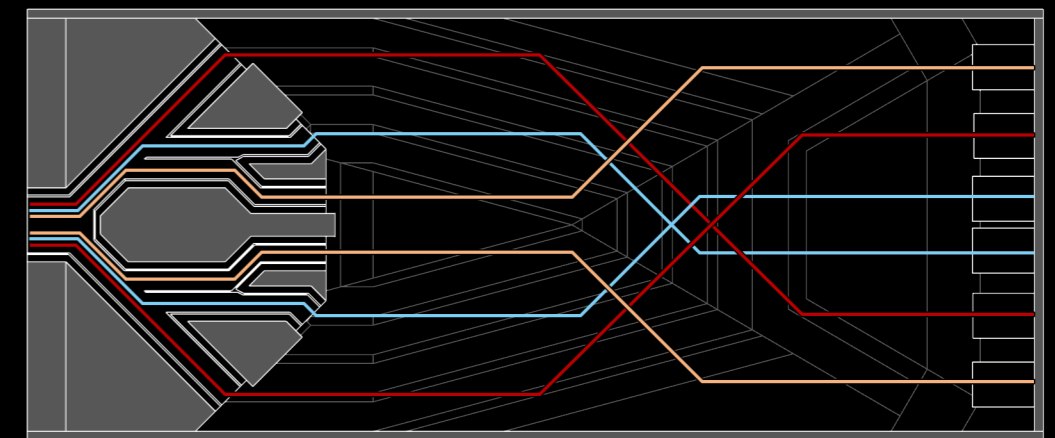
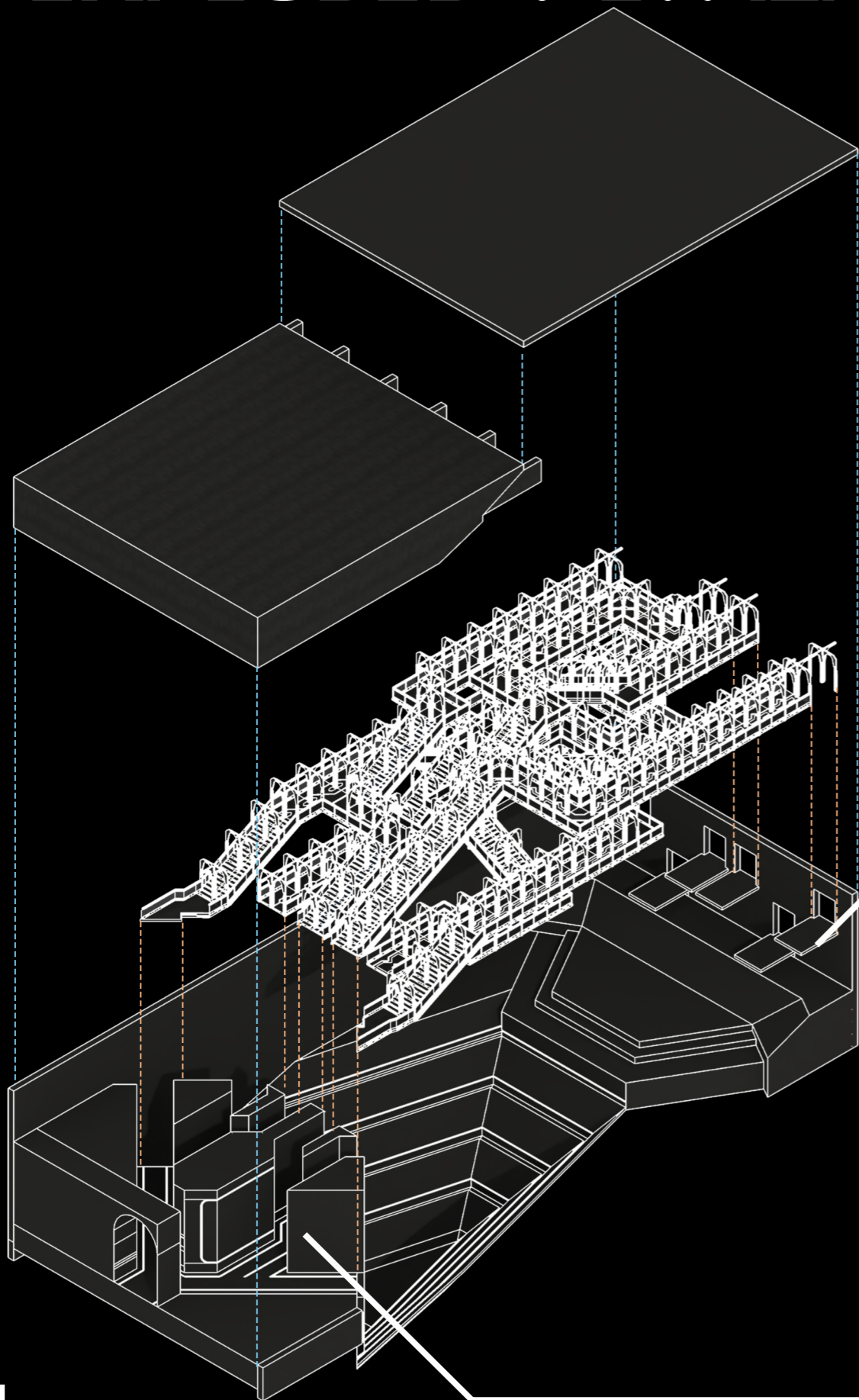

DIVERGENCE

THE CROWD GATHERED AT THE STARTING POINT OF THE SPACE, THEN IMMEDIATELY SPLIT INTO SIX DIRECTIONS, TRAVERSING THE SPACE ALONG THESE SIX INDEPENDENT ROUTES TO ENTER THE NEXT SECTION.



CHOICE

THE SOLID BLOCKS AND WALLS SEPARATE THE SELECTION DIRECTION, AND OTHER OPTIONS ARE NOT VISIBLE FOR A PERIOD OF TIME AFTER SELECTION.

+ THE STAIRS

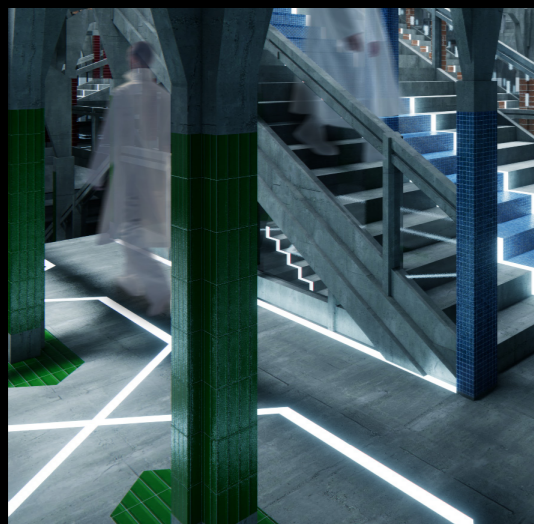

VERDANT GREEN TILE

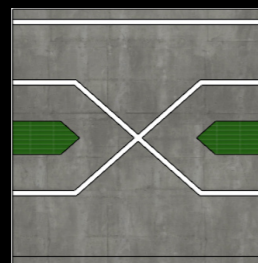
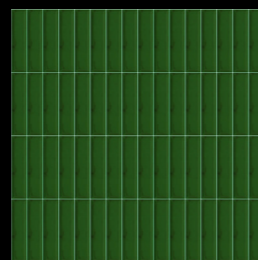

OX-BLOOD GLAZED TILE

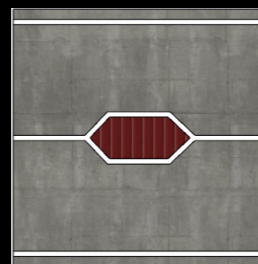

BLUE MOSAIC

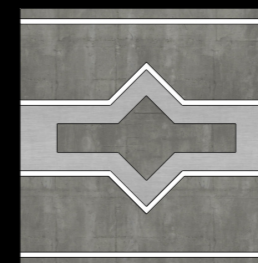
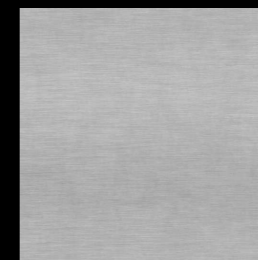
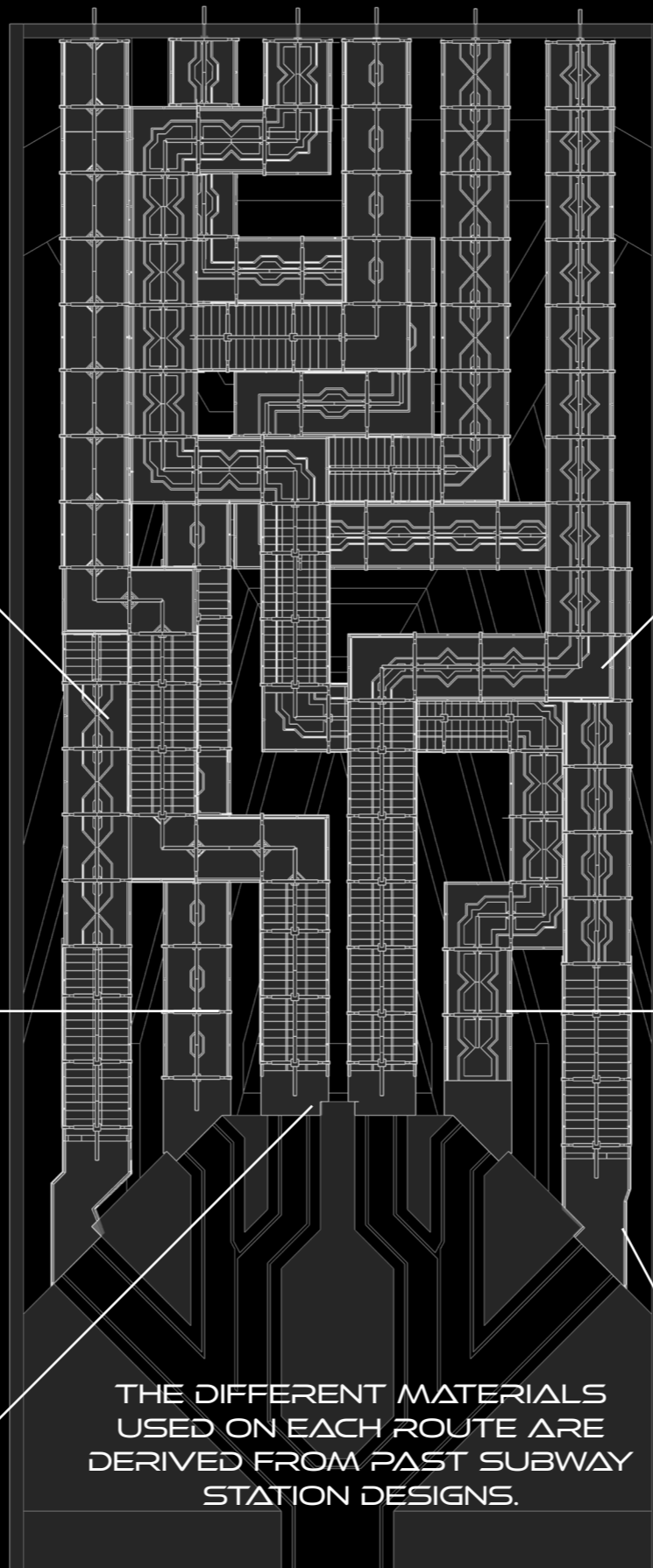
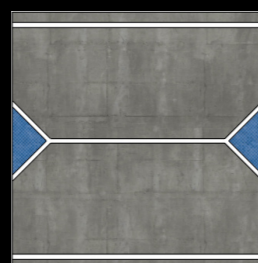
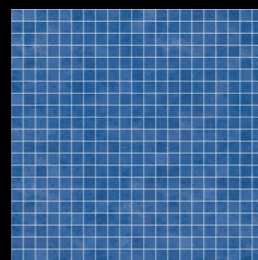

BRUSHED METAL PANEL

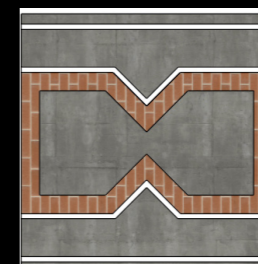
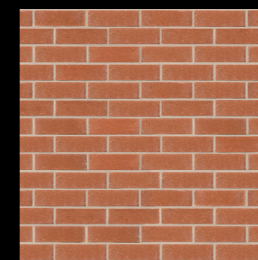

STOCK BRICK

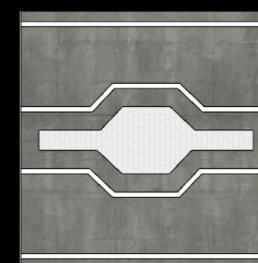
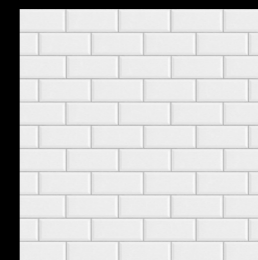

WHITE CERAMIC TILE

PART 4

THE CHAMBER OF LOOPS

PATHS FROM DIFFERENT DIRECTIONS CONVERGE HERE. PARTICIPANTS ARRIVE THROUGH SEPARATE ROUTES, YET MEET WITHIN THE SAME TRANSITIONAL SPACE — A REVOLVING PLATFORM THAT NEVER FULLY STOPS. HERE, MOVEMENT BECOMES CHOICE: TO STEP BACK INTO THE PREVIOUS PASSAGE AND BEGIN ANEW, OR TO MOVE FORWARD INTO WHAT FOLLOWS. THE SPACE LOOPS GENTLY, ITS RHYTHM NEITHER ENDING NOR BEGINNING, OFFERING A PAUSE WITHIN MOTION — A FLEETING MOMENT WHEN DECISION AND HESITATION COEXIST.



+ EXPLODED VIEW AND DETAILS +

64

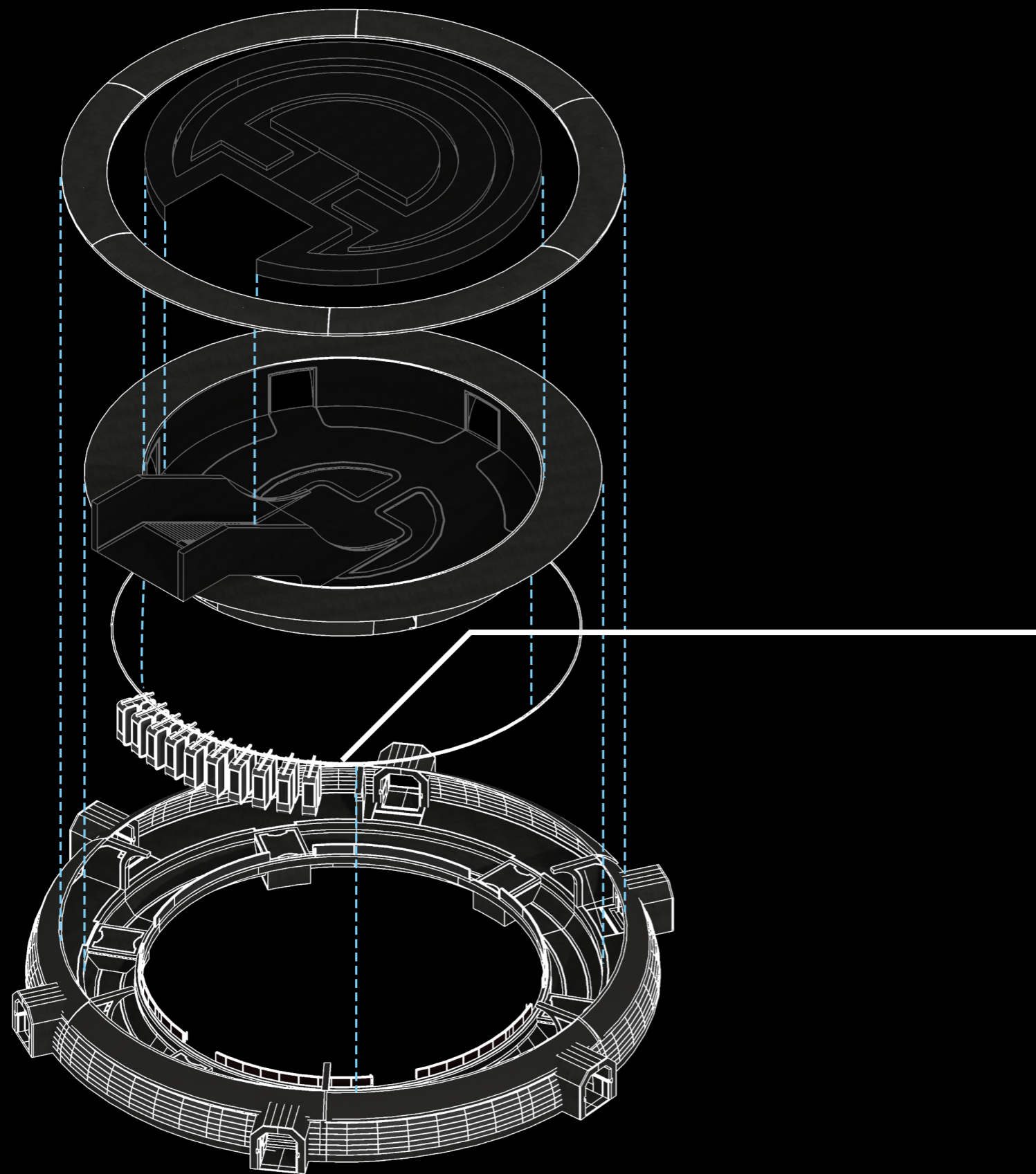

THE GLASS CHAMBER IS AN ABSTRACTED FORM OF A SUBWAY CARRIAGE. IT ISOLATES EACH INDIVIDUAL WHILE PRESERVING THE SENSE OF SYNCHRONIZED MOVEMENT WITHIN A SHARED SYSTEM.

THE GLASS CHAMBER

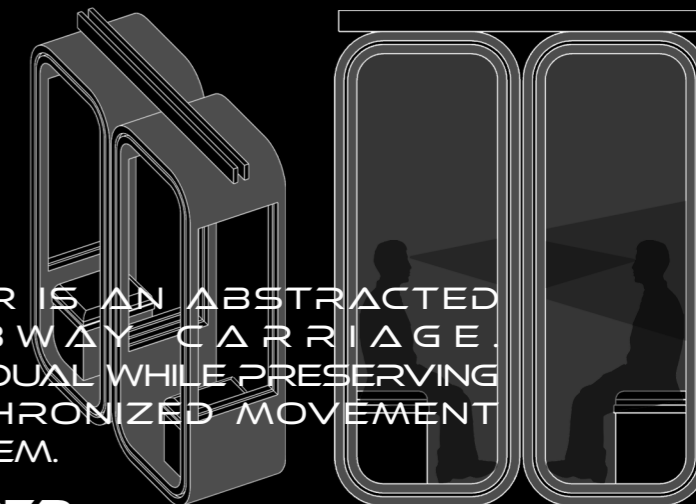

SHOWING INFORMATION



SHOWING OTHERS

INFORMATION IS PROJECTED ONTO THE GLASS, CREATING A PRIVATE VISUAL FIELD. WHEN THE PROJECTION IS TURNED OFF, ONE CAN SEE AND CONNECT WITH THE PERSON OPPOSITE.

INFORMATION PROJECTION

+ EXPLODED VIEW AND DETAILS +

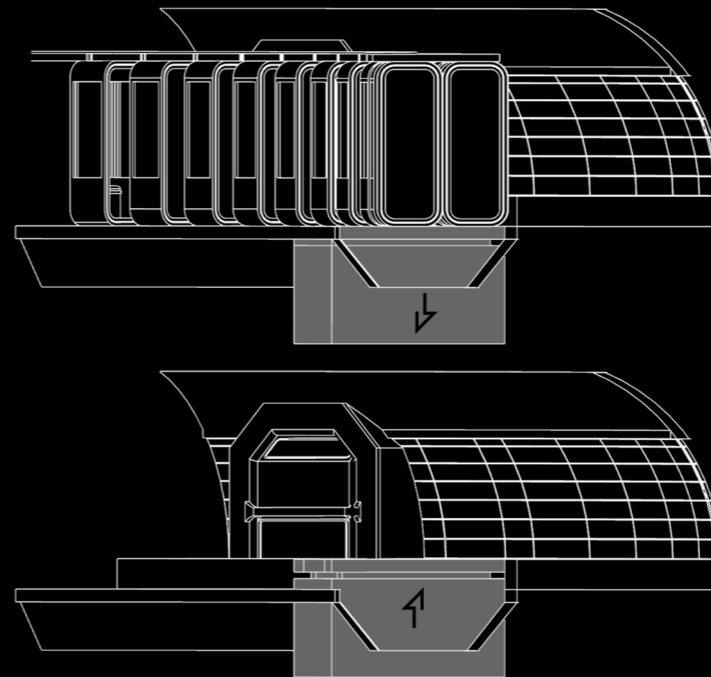
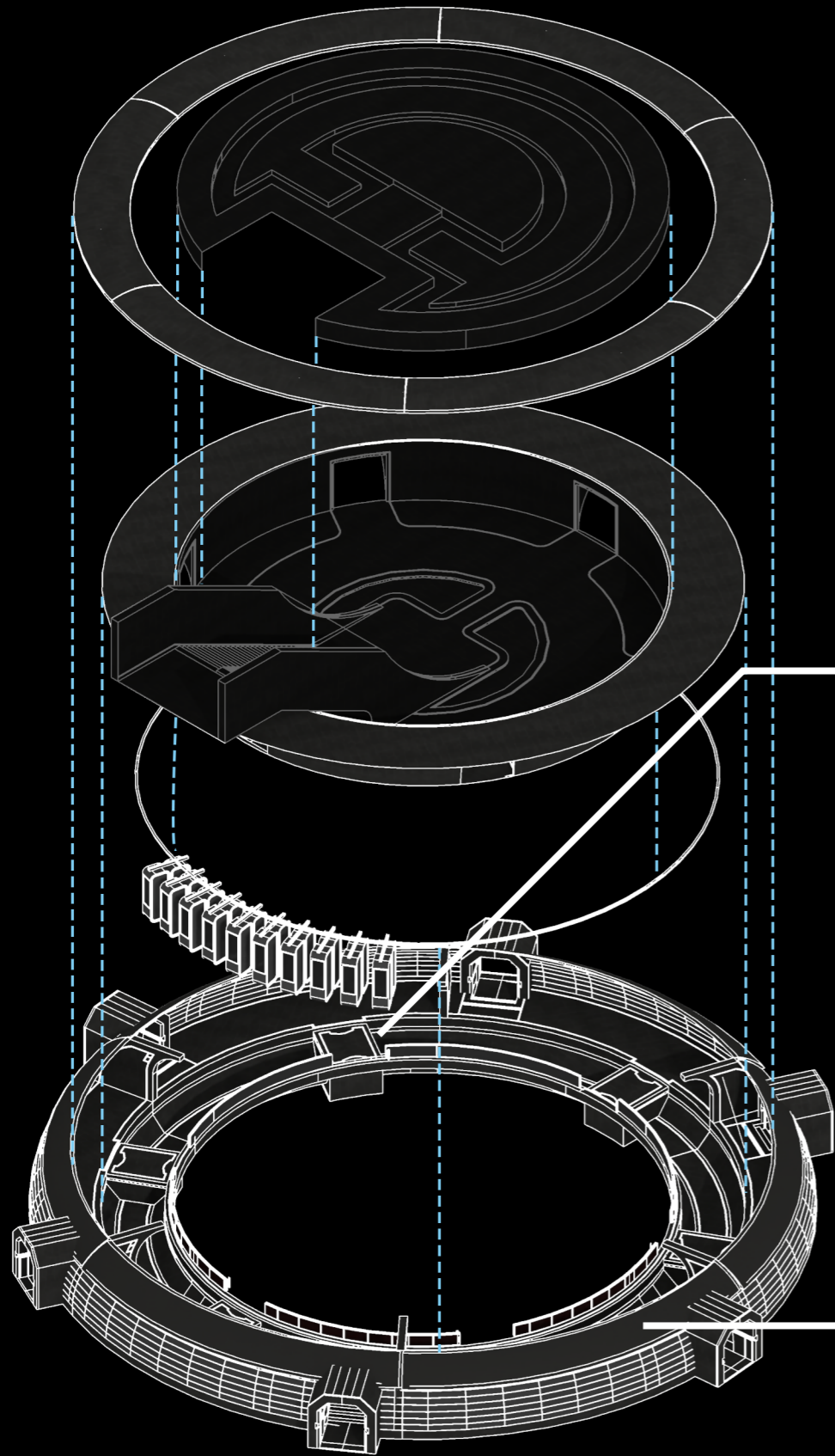

LIFTING PLATFORM

AFTER THE GLASS CHAMBER DEPARTS, THE LIFT PLATFORM WILL RISE, ALLOWING PARTICIPANTS TO ENTER THE NEXT SPACE, AND WILL DESCEND AGAIN BEFORE THE GLASS CHAMBER ARRIVES TO MAKE ROOM FOR IT.

65

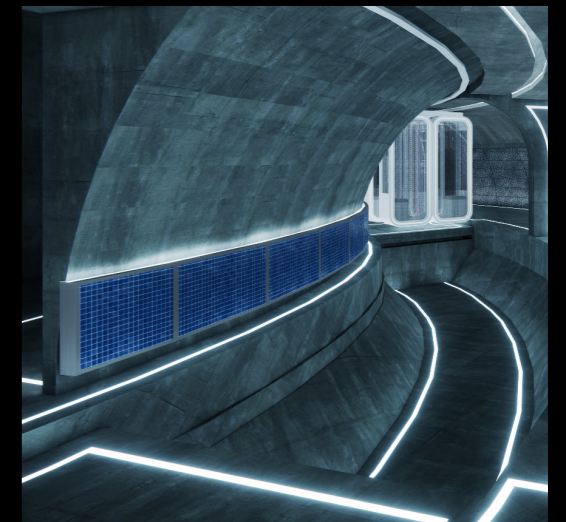

DECORATE

THE DECORATIVE MATERIALS USED IN THIS SECTION ARE THE SAME AS THOSE USED IN THE PREVIOUS SECTION OF THE STAIRCASE, INDICATING ITS LOCATION.



PART 5

THE CORRIDOR OF RETURN

WHEN THE GLASS CHAMBERS COME TO A HALT, PARTICIPANTS FACE TWO DIRECTIONS. SOME RETURN THROUGH THE CORRIDORS, RE-ENTERING THE HALL OF STEPS TO REPEAT THE CYCLE – A REFLECTION OF THE CONSTANT TRANSFERS WITHIN THE SUBWAY SYSTEM. OTHERS CHOOSE TO ASCEND ALONG A LONG PASSAGE LEADING BACK TO THE SURFACE. THE GRADUAL RISE RECALLS THE ACT OF LEAVING A STATION, A SYMBOLIC RETURN FROM THE CONTROLLED ORDER OF THE SYSTEM TO THE OPENNESS OF THE CITY. AS THEY REACH THE GROUND, THE SHARED IDENTITY DISSOLVES, AND EACH PERSON QUIETLY RESUMES THEIR INDIVIDUALITY.



+ EXPLODED VIEW AND DETAILS +

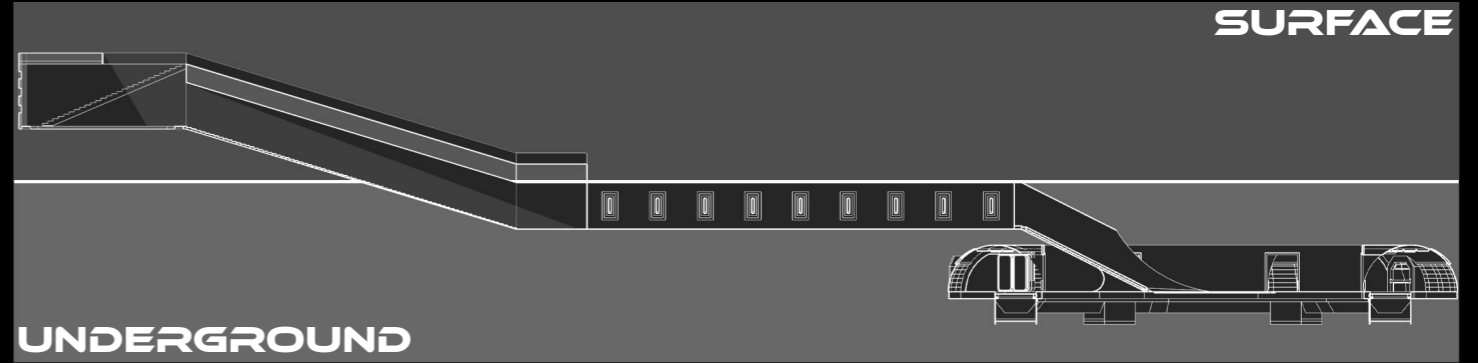
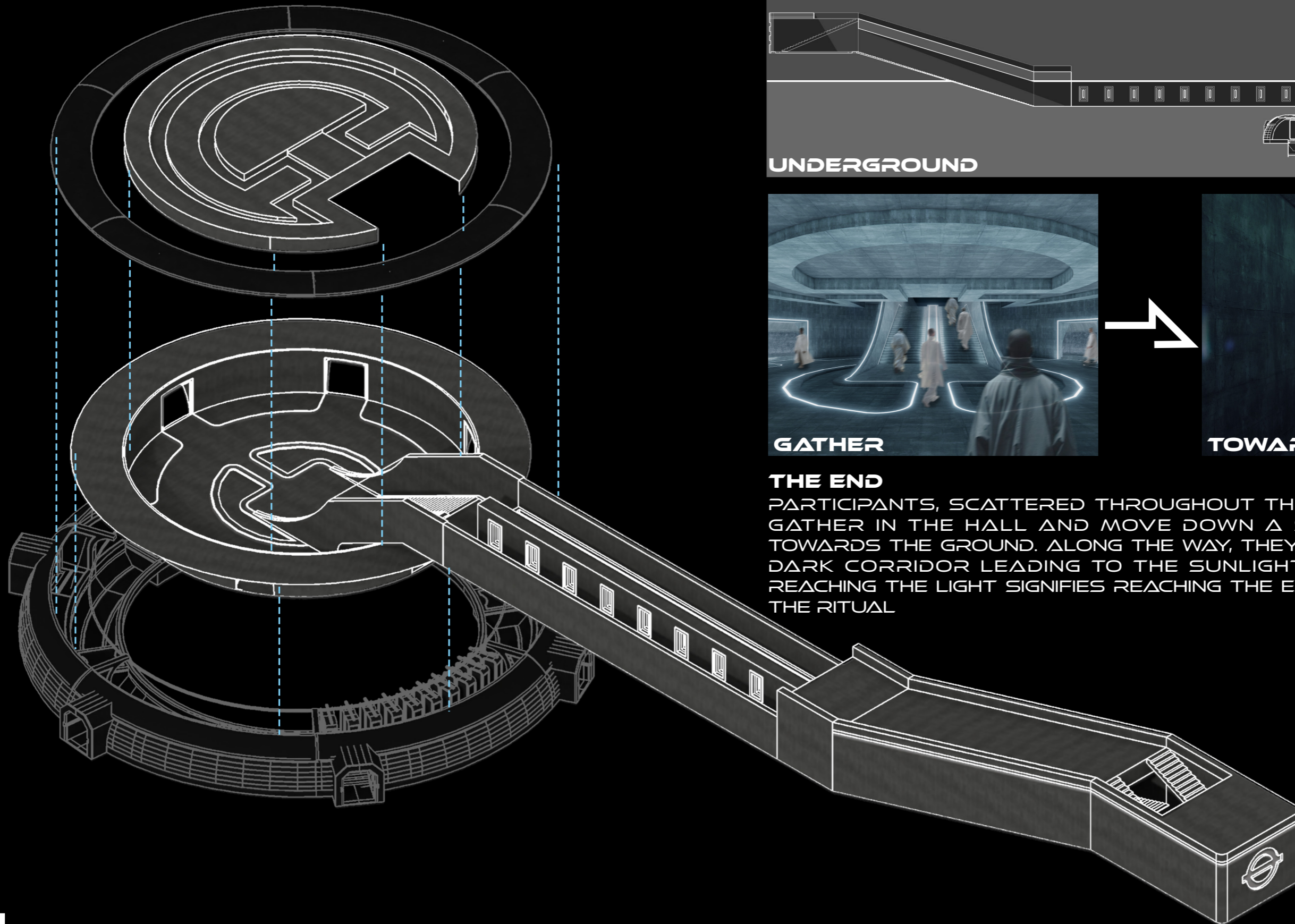

THE END

PARTICIPANTS, SCATTERED THROUGHOUT THE PREVIOUS SPACE, GATHER IN THE HALL AND MOVE DOWN A SINGLE STAIRCASE TOWARDS THE GROUND. ALONG THE WAY, THEY TRAVERSE A LONG, DARK CORRIDOR LEADING TO THE SUNLIGHT AT THE SURFACE. REACHING THE LIGHT SIGNIFIES REACHING THE EXIT AND THE END OF THE RITUAL