

Efficient short-range

Low cost

Technical support

Limited capacity

Policy constraints

Affected by weather

Drone

Efficient short-range:

UAVs are suitable for intra-urban and close-range transport and can quickly cut through congestion.

Low cost

low operating costs, suitable for frequent short-range missions.

Limited capacity

limited weight and range, suitable for small organ or sample transport.

Policy constraints

urban airspace control may affect flight permits, especially in densely populated areas.

Affected by weather

UAVs are susceptible to inclement weather, such as wind and rain, which can lead to unstable or interrupted flights.



BYD X DJI

BYD and DJI collaborated to launch the world's first integrated automotive drone.



It can take off and land with a single button, and provides high-definition, low-latency mapping to give owners a bird's-eye view and enhance the travelling experience.

Intelligent Storage

Automatic Battery Replacement

Charge Management

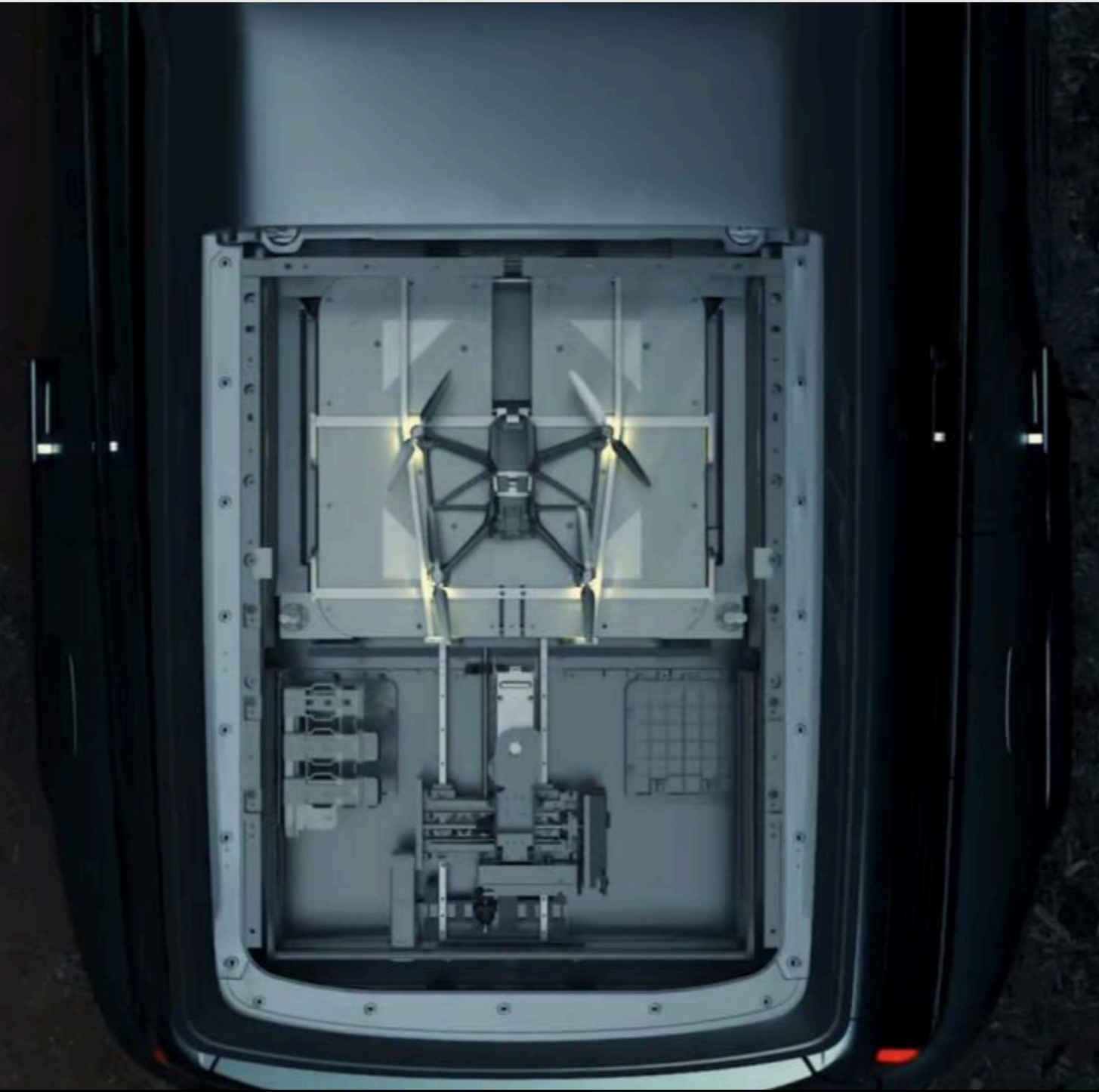

The roof compartment houses a modified DJI Mavic drone and three spare batteries which can be monitored by a roof-mounted camera that automatically loads the batteries into the drone before releasing them.



Equipped with a 49 kWh battery and a 75L fuel tank, it offers a 621-mile range while continuously powering the drone. Users can control the drone via the U8 infotainment system with built-in DJI Fly. After filming, the drone automatically returns and docks on the roof.



INTRODUCING
DJI FLYCART 30

Heavy Payloads, Long Distances

30 kg Max Payload ^[1]
28 km Flight Distance Without Payload ^[2]
16 km Flight Distance with Full Payload ^[3]
20 m/s Max Speed ^[4]

The first three indicators are measured in dual battery mode

Built for Extremes

6,000 m Max Flight Altitude ^[5]
-20° to 45° C (-4° to 113° F) Operating Temperature ^[6]
12 m/s Max Wind Speed Resistance ^[7]

Strong Signal

20 km Video Transmission with O3 ^[8]
4G Enhanced Video Transmission ^[9]
Dual Operator Mode ^[10]
High-Resolution FPV Gimbal Camera

Advanced Safety and Intelligence

IP55 Protection and Corrosion Resistance ^[11]
Radars, Binocular Vision, Intelligent Obstacle Sensing ^[12]
Dual Batteries and Parachute

Convenient Configurations

Foldable
70 L EPP Case ^[13]
Winch System

Fully-Automatic Operations

DJI Pilot 2
DJI DeliveryHub
Health Management System

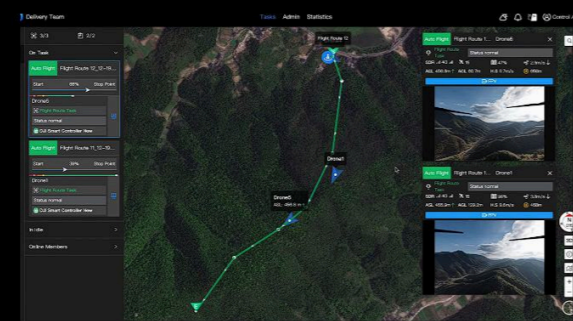

30 kg
Max Payload (Dual Batteries) ^[1]

40 kg
Max Payload (Single Battery) ^[1]



28 km
Max Flight Distance Without Payload (Dual Batteries) ^[2]

16 km
Max Flight Distance with Full Payload (Dual Batteries) ^[3]

20 m/s
Max Flight Speed (with Carbon Fiber Propellers) ^[4]

15 m/s
Cruising Speed ^[4]

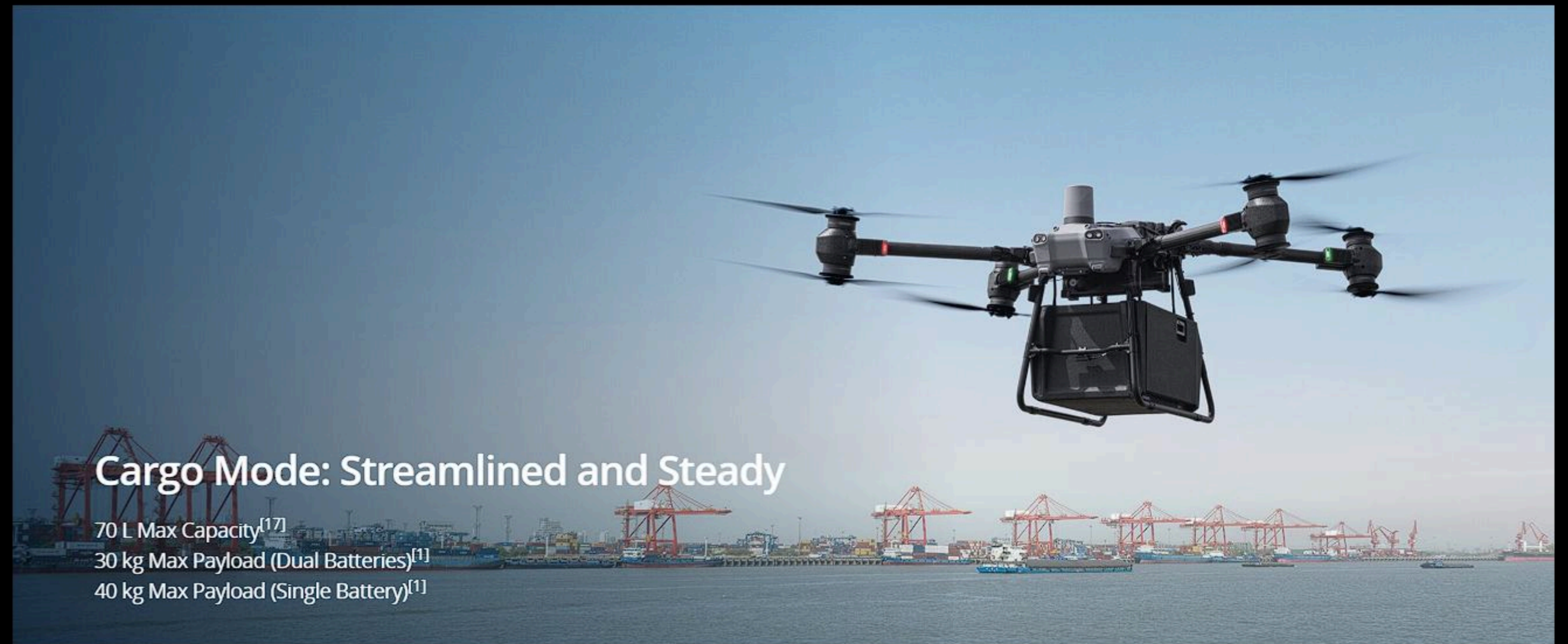

Cargo Mode: Streamlined and Steady

70 L Max Capacity ^[17]
30 kg Max Payload (Dual Batteries) ^[1]
40 kg Max Payload (Single Battery) ^[1]

Suitable market products



Photos of Amazon's new Prime Air drone, which can fly in light rain and deliver packages weighing up to five pounds in an hour

Eligible customers can choose from thousands of drone delivery items, including household essentials such as AA batteries (our most popular drone delivery item) as well as beauty and pharmacy products.

While current drones can be flown in sunny weather, the new MK30 can operate in more diverse weather conditions, including light rain.

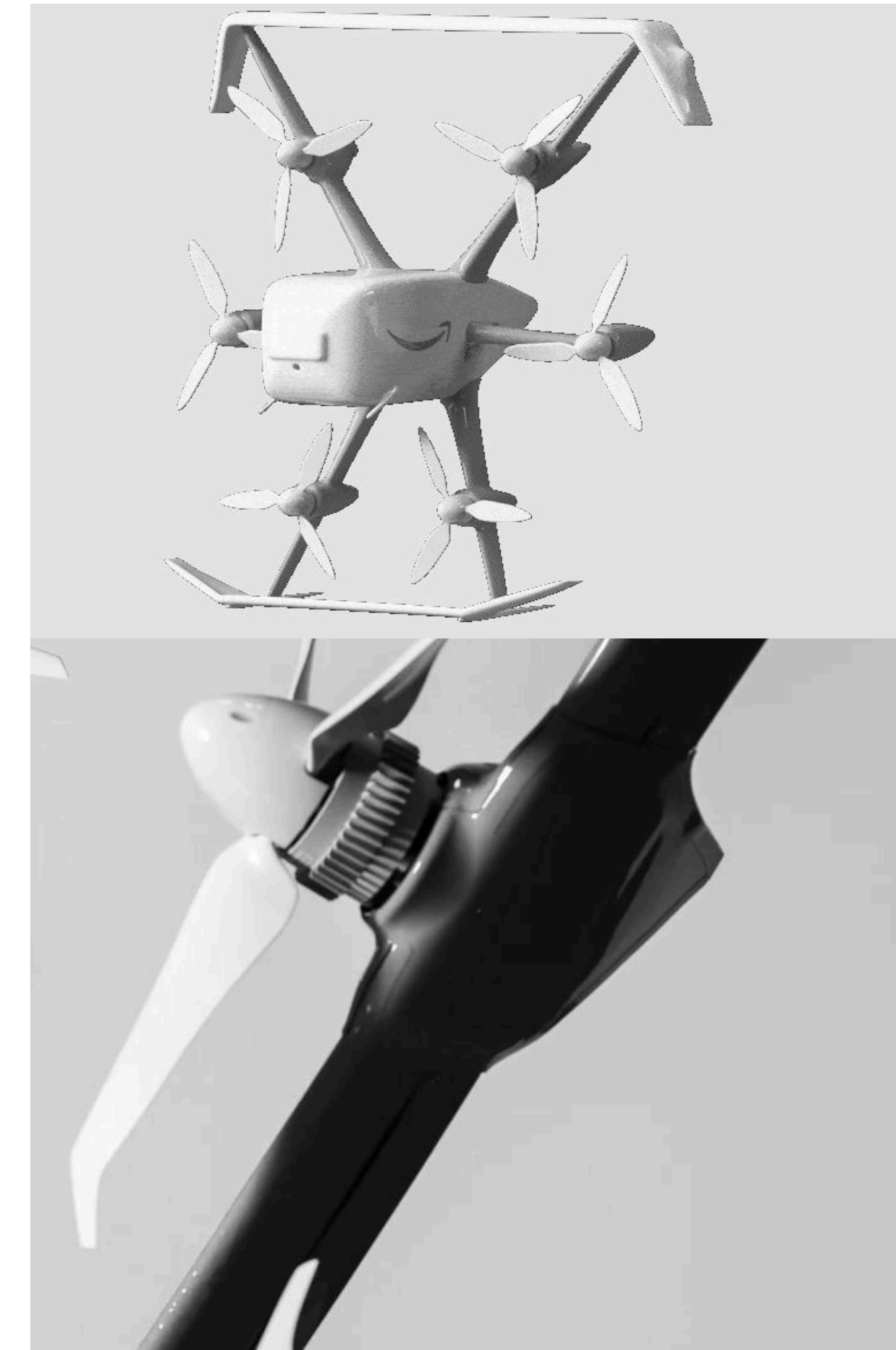



Containerised drones

Drones with built-in cargo bins have a more streamlined design that helps improve aerodynamics and protects cargo from environmental factors.

Enclosed warehouses provide greater cargo security against damage, theft and the effects of bad weather, especially when transporting sensitive or high-value goods.

Since the cargo is located inside the fuselage, heavier loads can usually be carried. Optimised internal cargo compartment design helps to spread the weight and improve transport efficiency.

Hanging Parcels

Cargo is usually suspended from the outside of the UAV and secured with the aid of hooks, net bags or other devices. This design is flexible and facilitates rapid loading and unloading, but may affect the stability and air resistance of the UAV.

Goods are exposed to the external environment and are susceptible to damage or loss, especially in bad weather. Therefore, this type of drone is more suitable for short-distance transport or less valuable items.

The load capacity is limited, especially when the cargo is suspended externally, which requires a high centre of gravity balance. In addition, mounting cargo increases air resistance and may affect range.



Organ transport

Safe usage scenarios

Commonly used in scenarios where transport stability and cargo protection are important, such as pharmaceutical and organ transport. The enclosed design helps to maintain temperature or minimise the effects of vibration.



Safety

Stability



Simple scenarios

It is more suitable for tasks requiring high speed and flexibility, such as e-commerce and food distribution, with fast loading and unloading of goods for short-distance distribution.

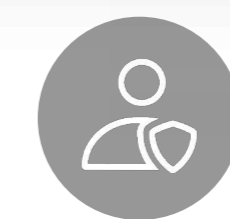

Security



Efficiency

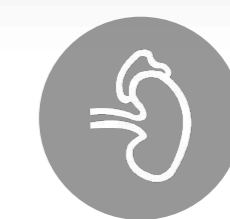

Organ stability

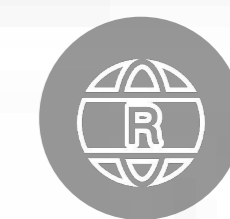

Policies



Technology

Conclu sion

Respondents generally agreed that they are willing to accept drones if they can improve healthcare efficiency and ensure safety. The main concerns centred on the reliability of the drones, noise issues, and government regulation, all of which need to be prioritised for future roll-outs



SAFETY

Design specification



Storage box



Control panel

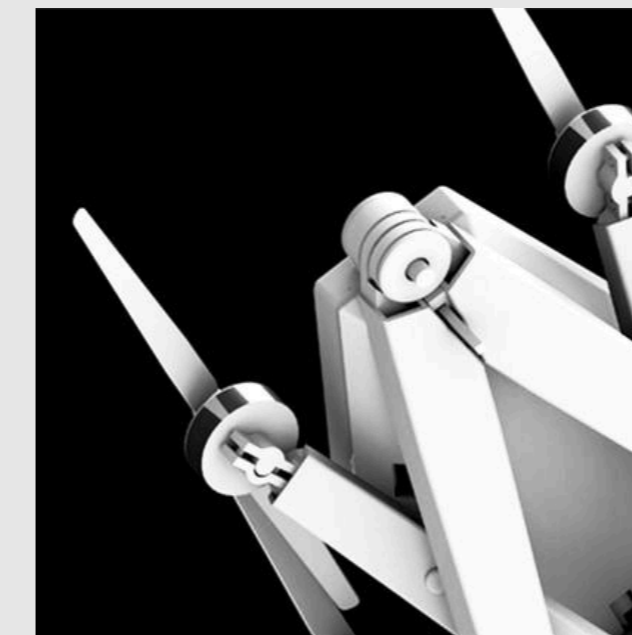

Folding Structure



Sonar Location



Drone parachute

Drones with built-in cargo bays enhance the stability and protection of medical supplies like organs and blood, offering better shielding from environmental changes than externally mounted payloads.

Integrated safety systems and environmental controls help alleviate public concerns about drone reliability.

To enhance safety, these drones feature emergency parachutes that deploy in case of failure, reducing crash risks and minimizing harm to people and the environment.

Demonstrating these safety mechanisms, along with transparent communication and strict regulatory compliance, can strengthen public trust and acceptance of drone-based medical transport.

organ preservation

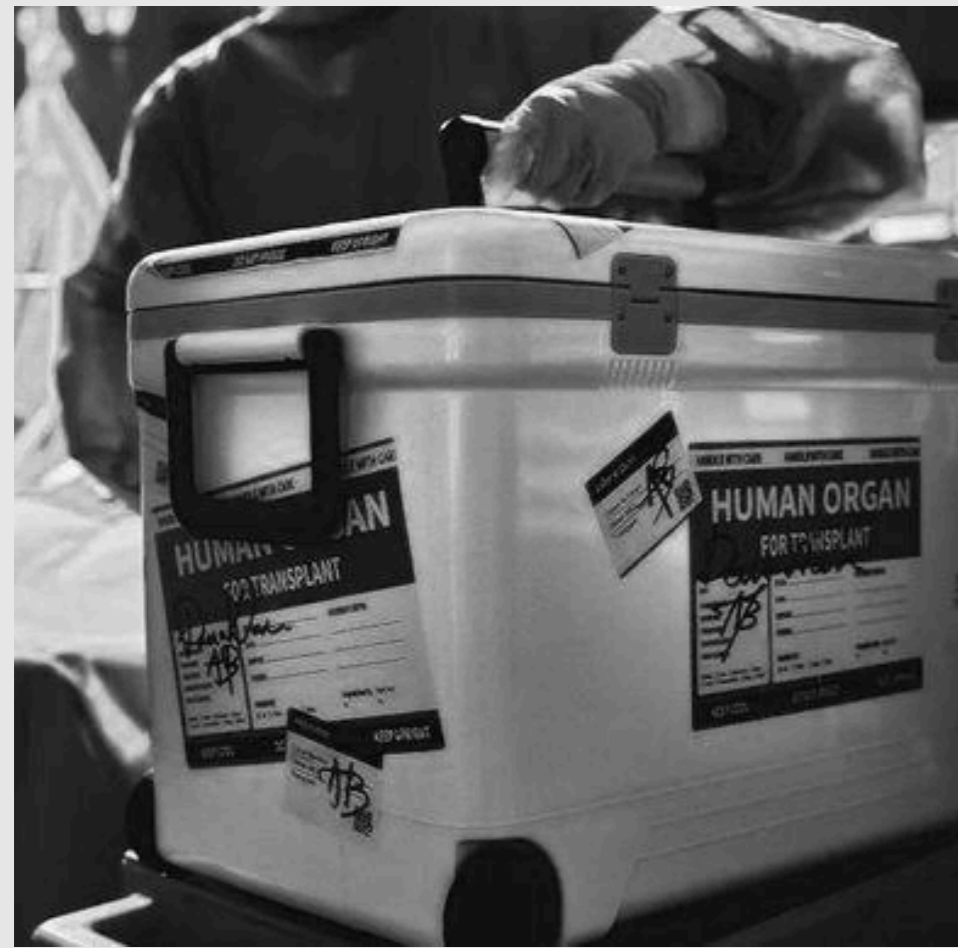

Static cold storage (SCS)

The simplest way to preserve organs by cryopreservation without active circulatory devices.

Approved for clinical use in kidney and liver.

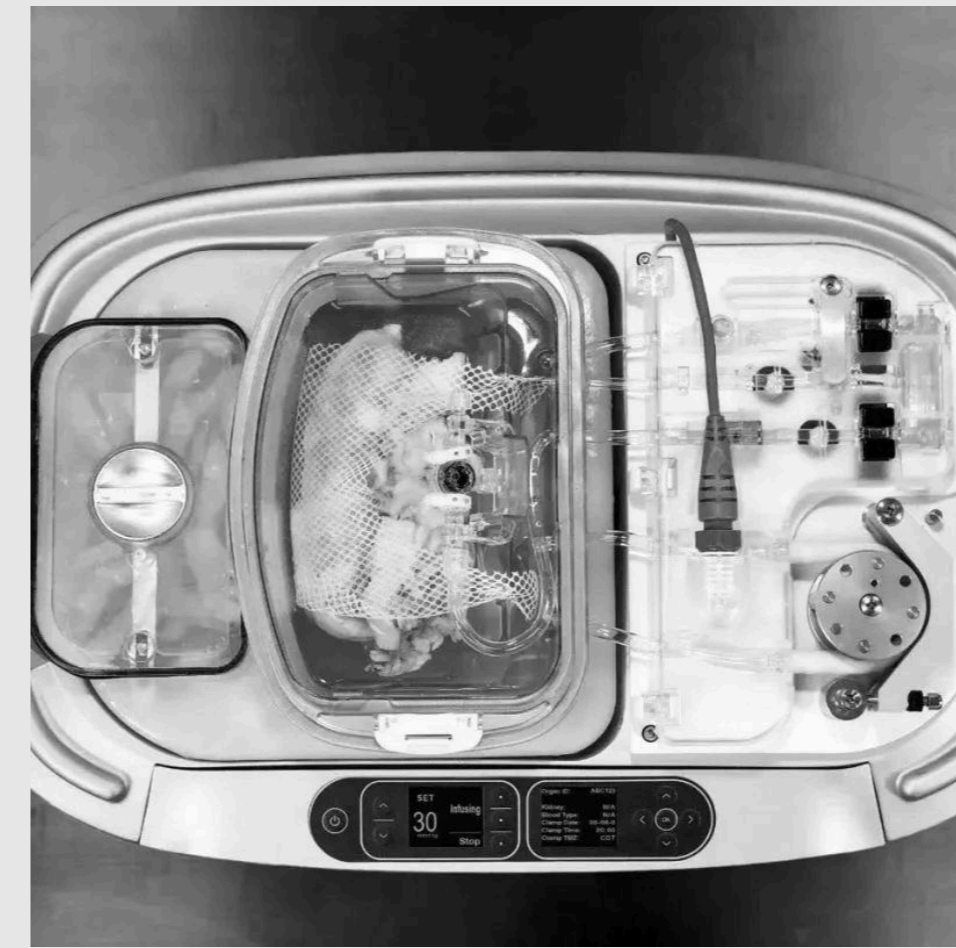

Cryogenic machine perfusion (HMP)

A machine is used to continuously perfuse organs in a cryogenic environment to help maintain supply and remove metabolites.

It has been approved for use in the kidneys.

Normal temperature machine infusion (NMP)

Perfusion of organs at temperatures close to the physiological temperature of the body to maintain organ function and observe status.

Still in clinical trials and not yet widely used.

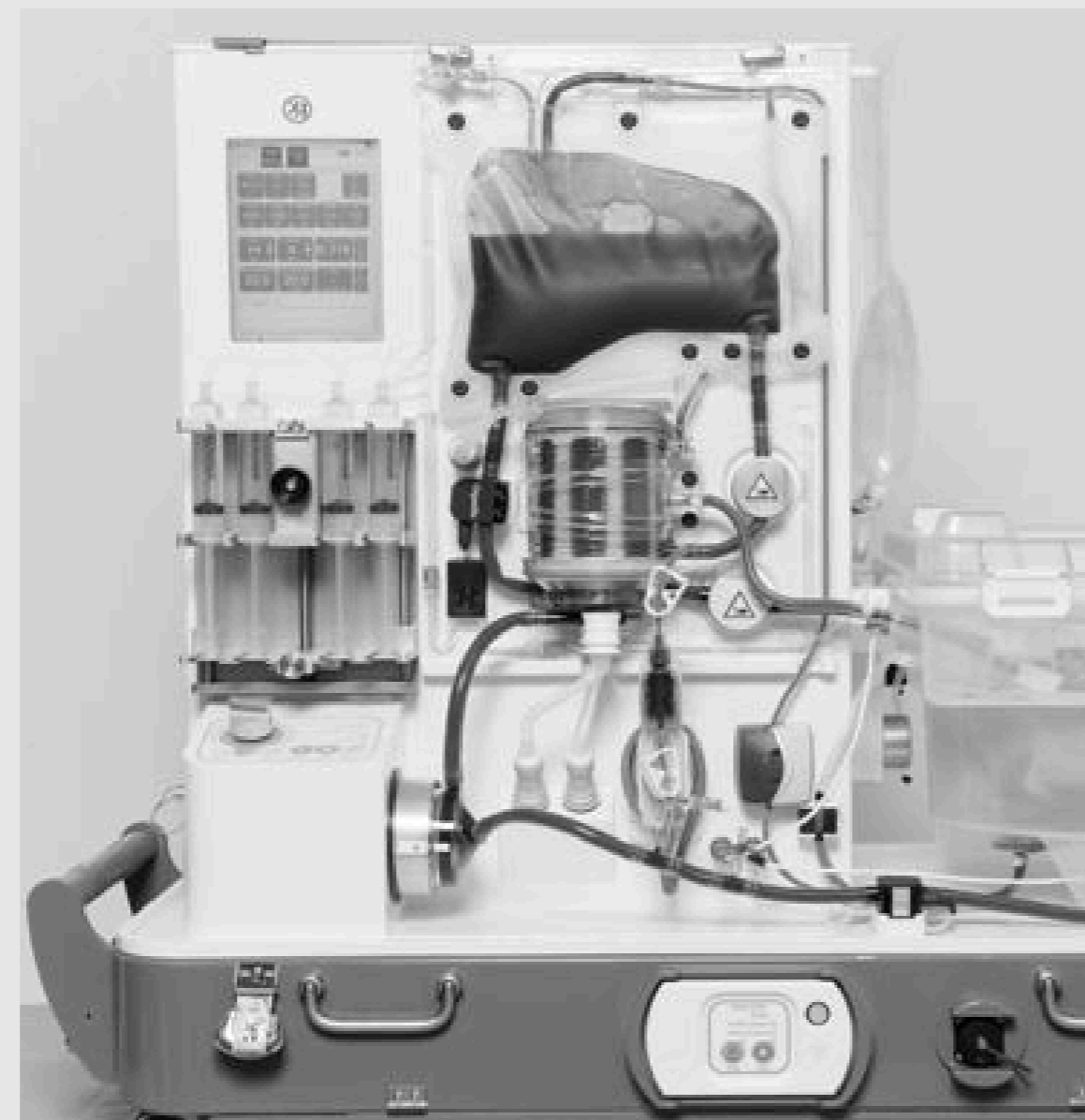

Oxygen blowing (OP)

Blowing oxygen into tissues to maintain oxygenation.

Currently mainly in preclinical or early clinical trials.

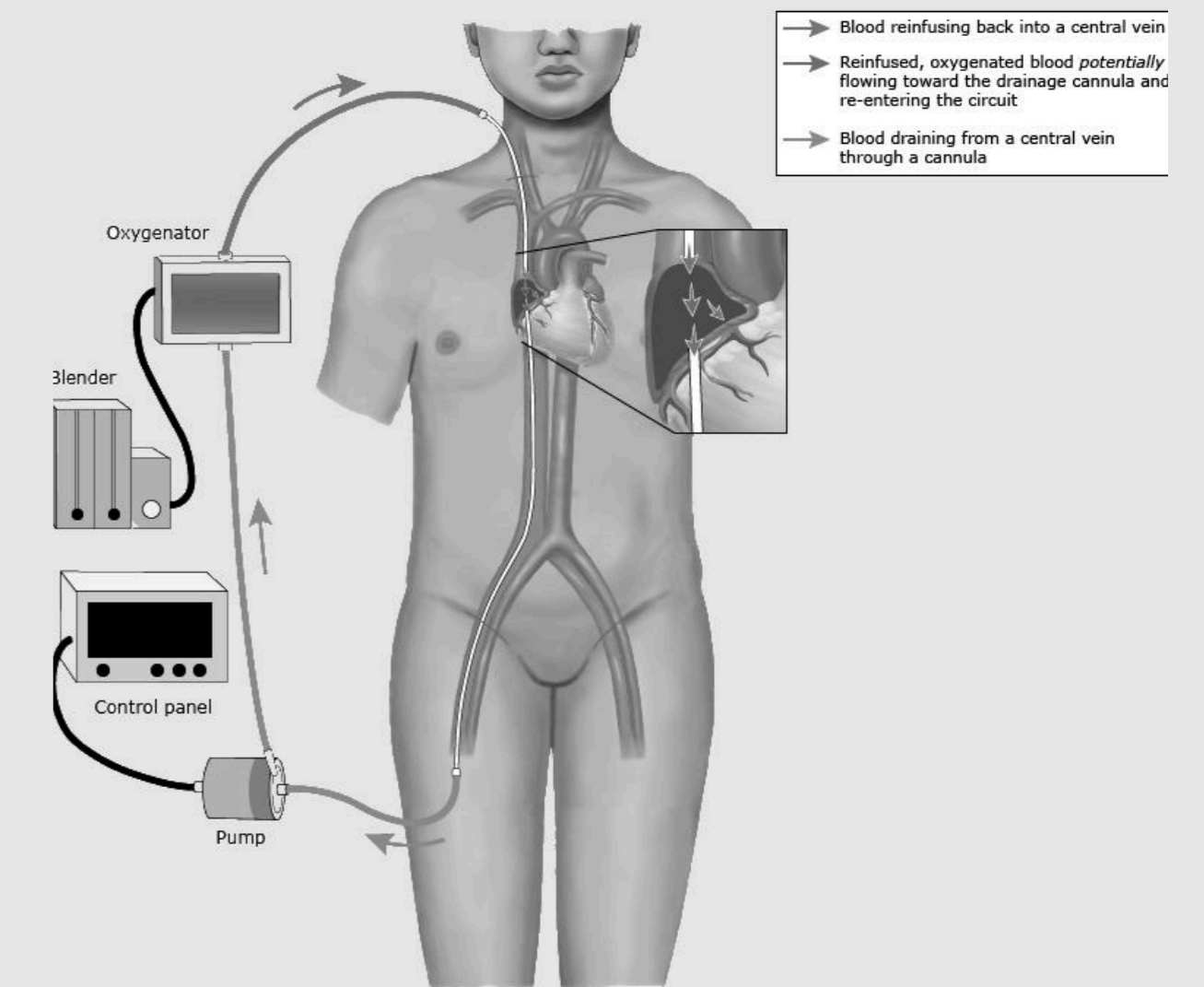

Schematic

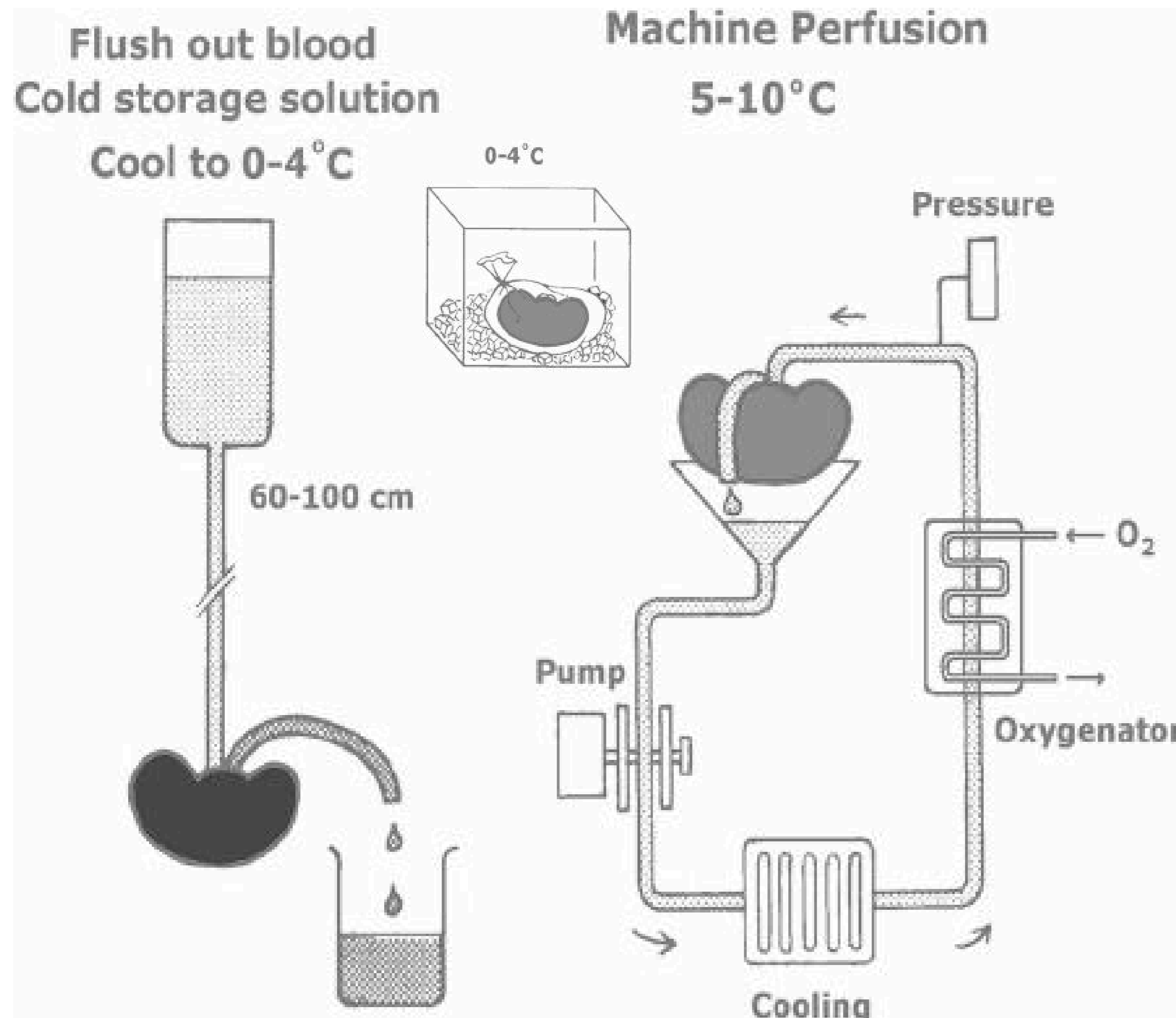

Schematic diagram of static refrigeration and machine perfusion

Left:

Blood is flushed from the kidneys by the cryopreservation solution before static freezing. The organ is then immersed in the preservation solution and kept in a box on melted ice (0 - 5 °C).

Right:

Before machine perfusion, the kidney is flushed out, then its artery is connected to the perfusion circuit and immersed in a cassette containing preservation solution (5°C). The solution is pumped

What need to be improved

Storage

Why do traditional medical kits fail?

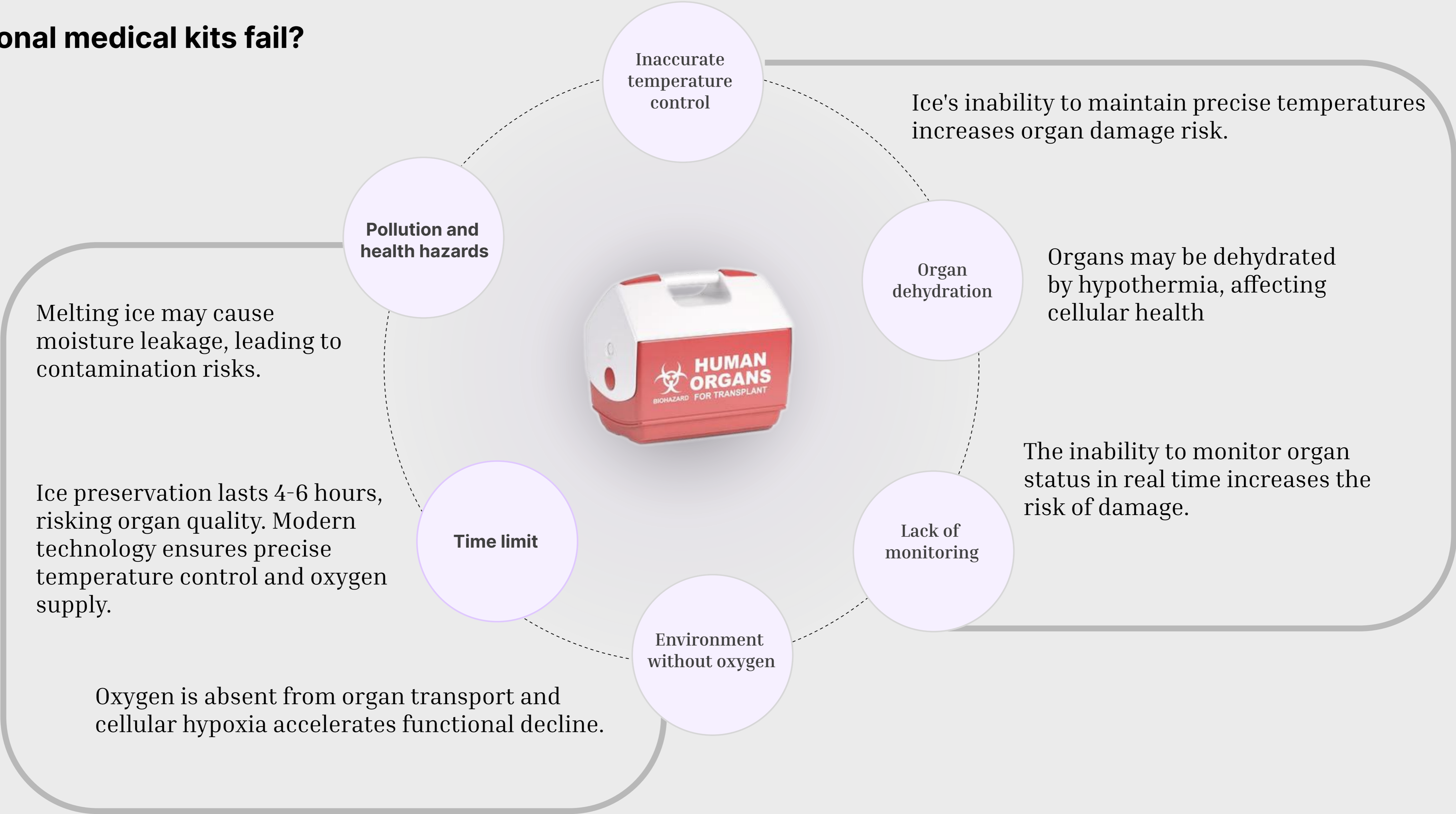

Transmedics' organ care system prolongs organ preservation by mimicking the human environment and avoiding the cold ischaemia associated with traditional ice storage.

Business example

The best ambient organ perfusion system on the market today, from which we make our products!



Organ Care System Heart

The portable system uses retrograde perfusion to maintain cardiac beating, prolonging ischaemic time and enabling preoperative assessment.



Organ Care System Lung

Simulates the human environment to maintain lung respiration, circulation and constant temperature, ensuring stable function during transport.



Organ Care System Liver

The system maintains organ body temperature, protects organs through blood, oxygen and nutrient perfusion, and regulates perfusion pressure and flow.

Storage conditions

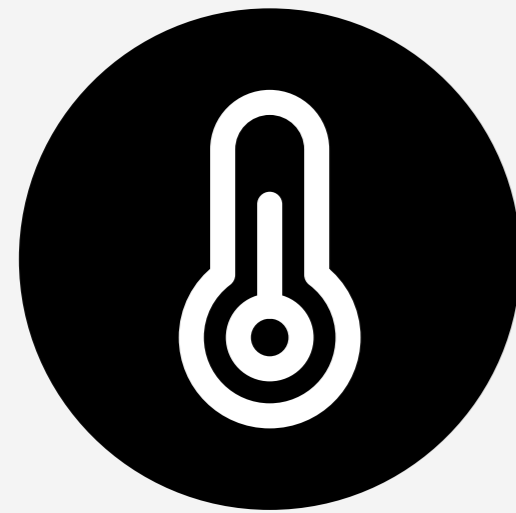

Temperature Setting

Organs Should Be Kept Between 2-8°C To Avoid Freezing Or Damage.

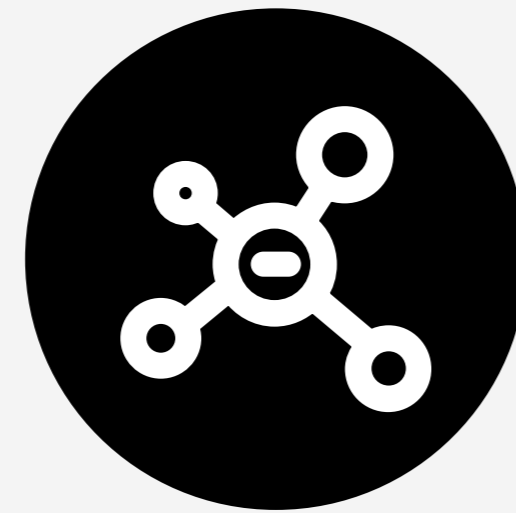

Metabolism Reduction

Use Preservation Fluids (E.G., UW, HTK, Celsior) To Reduce Metabolism And Maintain Stability.

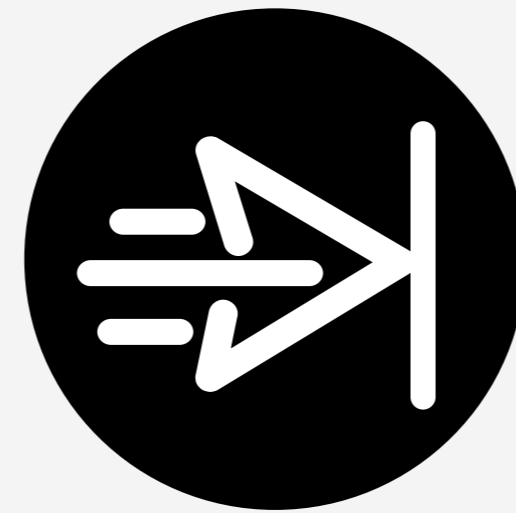

Shock Resistance

Protects Organs From Shocks During Transport.

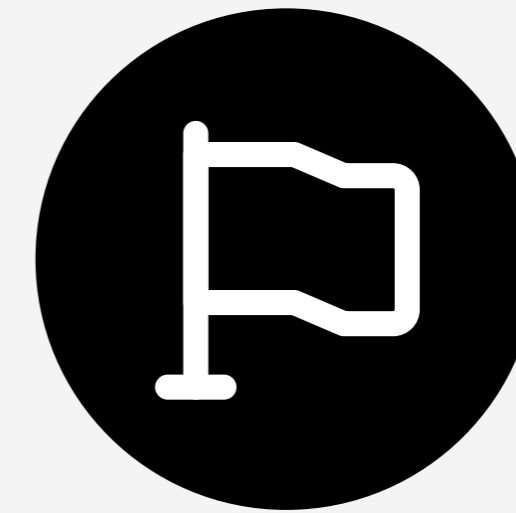

Markings

Labeled As "Human Organs" With Emergency Transport Symbols For Quick Identification.



GPS Tracking

Enables Real-Time Monitoring Of Transport Route And Status For Timely Delivery.

Technologies

Perfusion system

Providing nutrients and oxygen by pumping oxygenated liquid, Thus simulating physiological conditions.

Advantages

Extending organ preservation time and improving organ quality, especially for the heart and liver.

Tec: Kidney dialysis

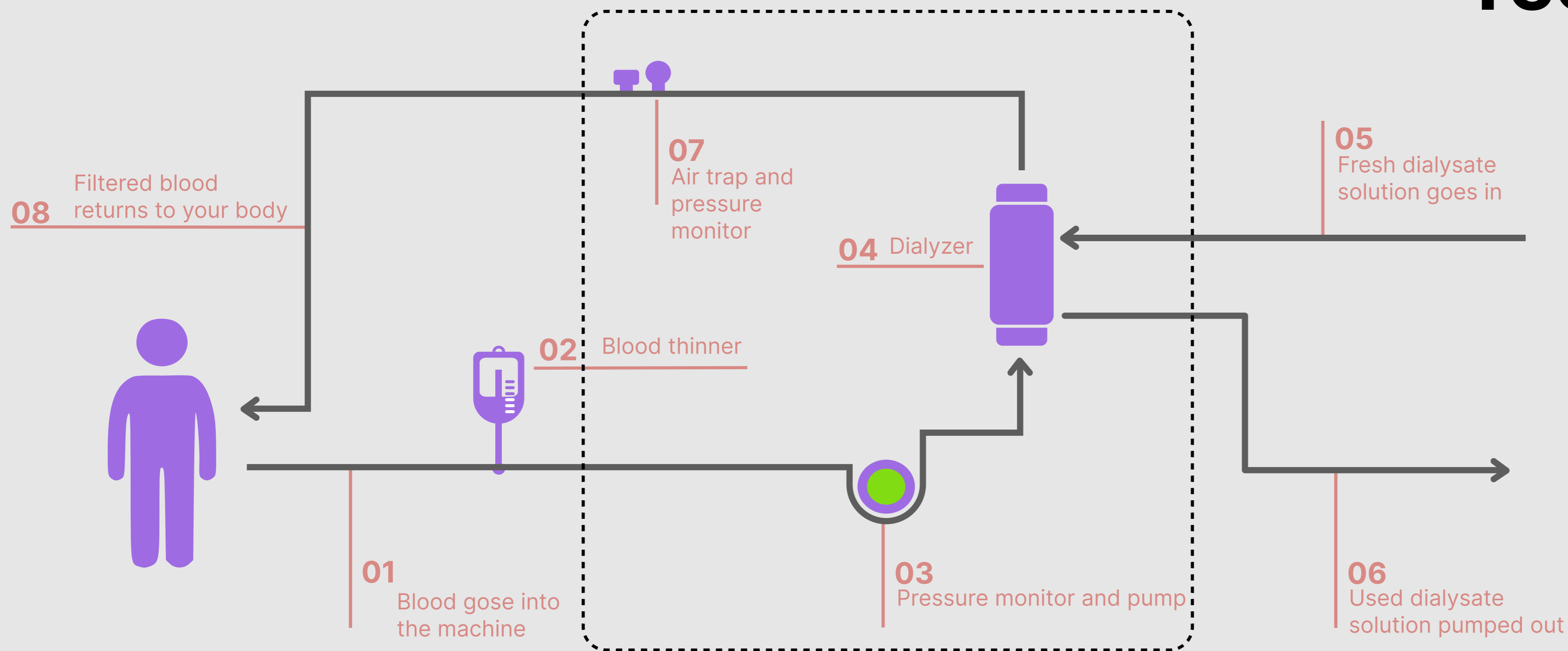

Two tubes are connected through a hemodialysis circuit. Blood flows from your body into the machine through one of the tubes. If your doctor has prescribed a blood thinner as part of your treatment, it will be added to prevent your blood from clotting in the machine. Pressure monitors and pumps work together to maintain the correct flow rate. Your blood enters the dialyzer, where it is filtered. Dialysate flows into the dialyzer to remove waste from the blood. The used dialysate is then pumped out and discarded. Finally, your blood passes through another pressure monitor and air trap to ensure it can safely return to your body via the second tube connected to your access site.

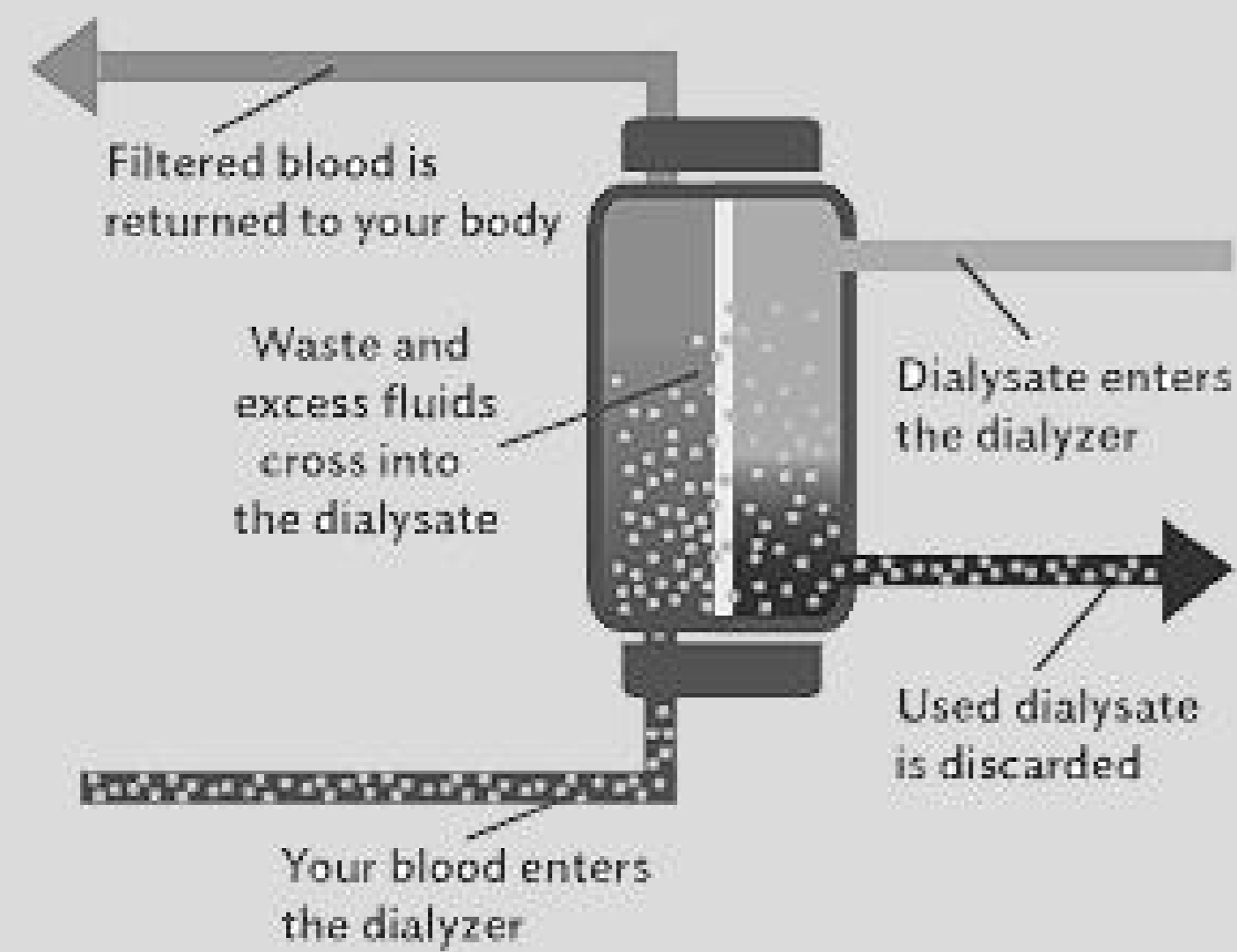

Dialysate is a fluid made up of water, electrolytes and salts. During dialysis, the dialysate helps clean the blood inside the dialyzer by removing waste products and balancing electrolytes.

The dialyzer contains thousands of mesh tubes. Blood flows inside them while dialysate outside removes waste through tiny holes. The cleaned blood then returns to your body.

During dialysis, key data (pump speed, blood pressure, temperature) is displayed for safety. Alarms signal issues; home patients are trained with 24/7 support, while center patients are monitored by staff.

Tec: DIALYSATE?



Renal dialysis equipment

NCU-18



图 1-3 装置整体图（背面）

No.	名称	功能
1	酸液接头	酸洗时，连接酸液罐的接头。
2	消毒液接头	消毒时，连接消毒液的接头。
3	供水口	进水的连接口。
4	排液口	排出使用过的透析液的连接口。
5	ETRF1 精密过滤器盖 (选配件)	ETRF (精密过滤器) 1 的外盖。
6	ETRF2 精密过滤器盖 (选配件)	ETRF (精密过滤器) 2 的外盖。
7	液体回路冷却扇	热水清洗时，冷却液体回路的电子零件。
8	中央接口 B1/A2 (选配件)	集中配管的连接口。
9	中央接口 A1 (选配件)	集中配管的连接口。

1.2. 操作面板

1.2.1. 各部位名称

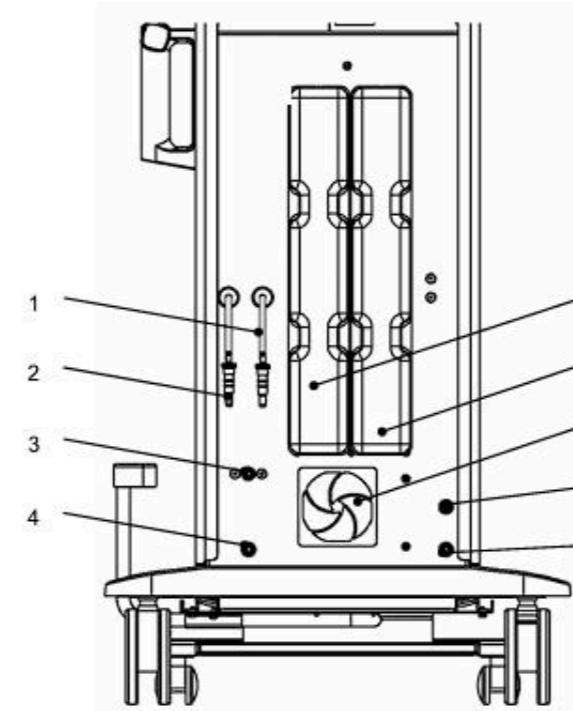

图 1-4 操作面板（整体）

No.	名称	功能
1	I/O 电源开关	将装置背后的电源断路器打开，按下电源开关，装置处于可使用状态。关闭 I/O 电源开关则装置所有功能都停止。（但电池电路等一部分仍在通电）
2	I/O 指示灯	装置启动后点亮。
3	供电指示灯	供电时显示绿灯，停电时熄灭。
4	触摸式显示屏	各种设定或显示执行透析等操作的指示画面。
5	血泵流量设定旋钮	旋转血泵流量设定旋钮，可改变血泵的流量。往右旋转，血泵流量上升 5mL/min。往左旋转，血泵流量下降 5mL/min。

注意

- 触摸显示屏使用的是 TFT 彩色液晶屏。液晶屏容易受损，请勿使用尖锐的物体触摸或摩擦液晶屏的表面。
- 触摸显示屏是玻璃制品，请小心避免机械性撞击。
- 如触摸显示屏内的开关或液晶屏出现故障，请迅速关掉电源开关，中断治疗并将患者与装置分离。
- TFT 彩色液晶屏是用精密非常高的技术制作而成的，画面的一部分像素有时不点亮或时常点亮。从不同角度看，色彩或亮度或有不均匀。这些是由液晶屏结构引起的，并非故障。

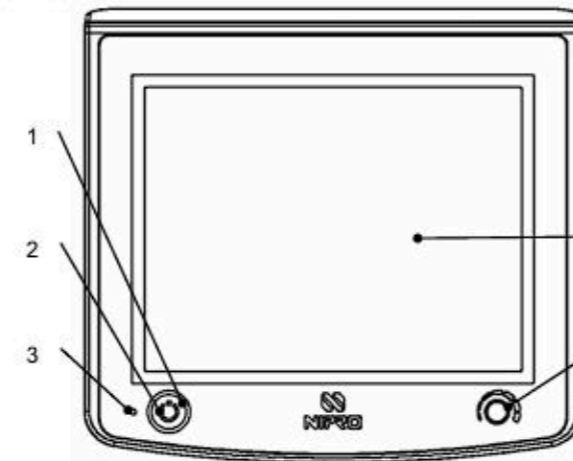
1. 装置结构

1.1. 装置整体

1.1.1. 各部位名称及功能



图 1-1 装置整体图（正面及右侧面）

No.	名称	功能
1	操作面板	对装置进行设定及透析等各流程做出操作指示。
2	肝素泵	装设注射器，按规定的速度注入药物。
3	血泵	将血液送入血液管路内。
4	补液泵 (选配件)	将补液送入血液管路内。
5	前板	维修装置内部的液体回路时打开。
6	原液罐台 (选配件)	放置 A、B 原液罐。
7	4 连指示灯	用 4 个指示灯来显示装置的状态和当前的流量及报警等。
8	挂架	支撑补液器等。
9	支柱	用于支撑透析器和输液管等。
10	支柱固定螺丝	固定支柱。
11	支柱夹	安装支柱的夹具。
12	右侧面板	维修装置内部的液体回路及电子设备时打开。
13	酸液、药液架 (选配件)	托放酸液、药液的罐。

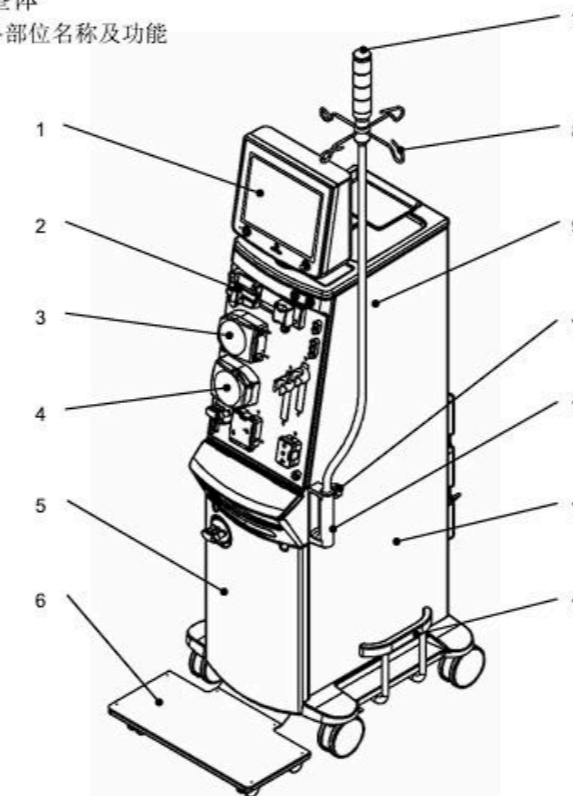

图 1-2 装置整体图（背面及左侧面）

No.	名称	功能
1	内置 IC 读卡机 (选配件)	用于 IC 卡的读出和输入。
2	托盘	放置注射器等小物件的盒子。
3	袖带连接口	连接制造商指定的血压测量袖带。参照「13 血压计 (选配件)」。
4	电子风扇	冷却电源部。
5	呼叫护士的连接口	选择制造商指定的呼叫按钮。
6	血压计遥控开关连接口	选择制造商指定的血压计遥控开关按钮。
7	电源线	电源插头插入电源插座，向装置供电。
8	等电位插头	连接合适 DIN42801 的等电位导线。
9	B 型托架	装设 B 型架。
10	LAN 连接口	连接网络格式社会信息管理系统。
11	电源断路器	接通或断开电源。
12	左侧面板	维修装置内部的液体回路时打开。

1.3. 血液管路安装构成

1.3.1. 各部位名称及功能

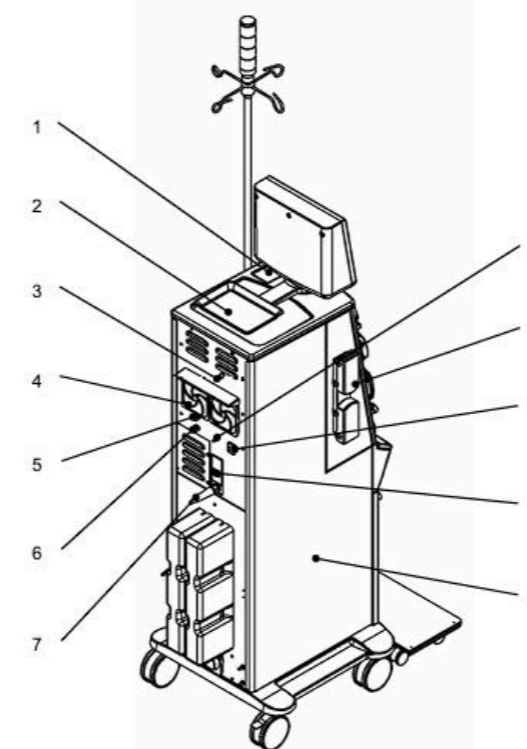

图 1-5 血液管路安装部

No.	名称	功能
1	注射器托架	装设注射器的托架。
2	注射器压杆	固定注射器的可动压杆。
3	管路导槽	压住血液管路的防止上翘。
4	手柄	将滚轮与电机轴连接。
5	滚轮	滚压血液管路并将血液送出。
6	补液接口 (选配件)	连接在线补液管路，用于在线补液。支持生理盐水或在补液管的自动预充/回血。
7	SPR 组件 (选配件)	动脉夹钳 生理盐水夹钳
8	透析液回收口	回收从透析器流出的使用过的透析液。



图 2.3 数据输入示例（治疗数据）

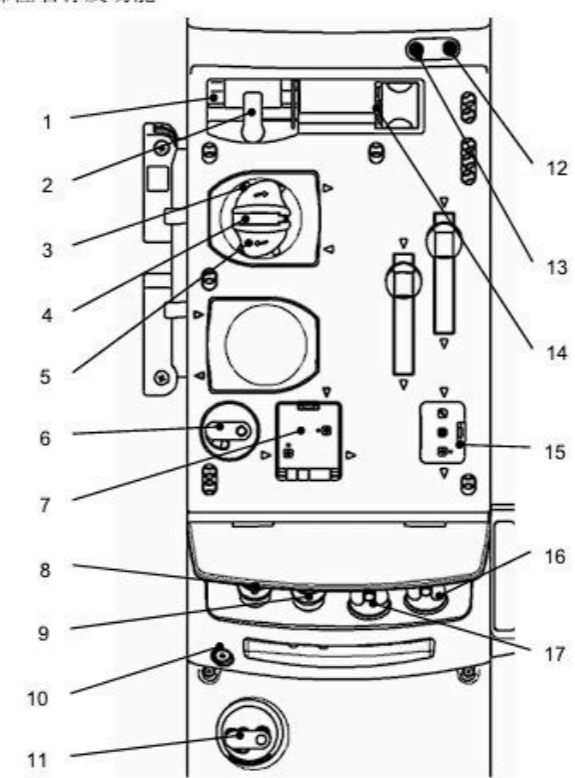
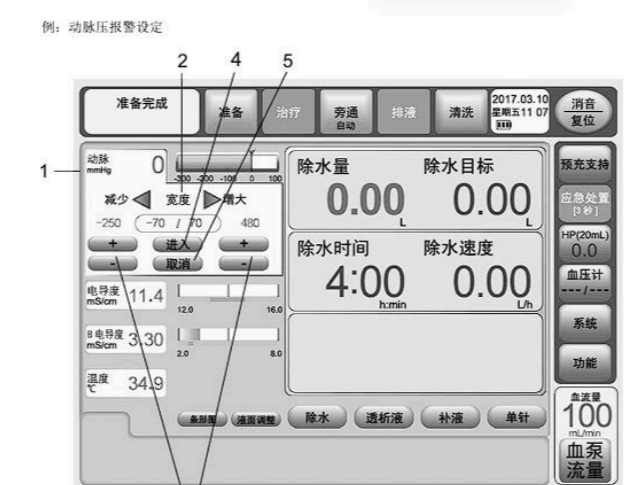

No.	名称	说明
1	目标除水量显示	触摸显示区域后，显示目标除水量。
2	十一号按钮	设定目标除水量。
3	十一号按钮	设定上下限报警数值。
4	进入按钮	确定设定。
5	取消按钮	取消设定。

2.2. 治疗画面

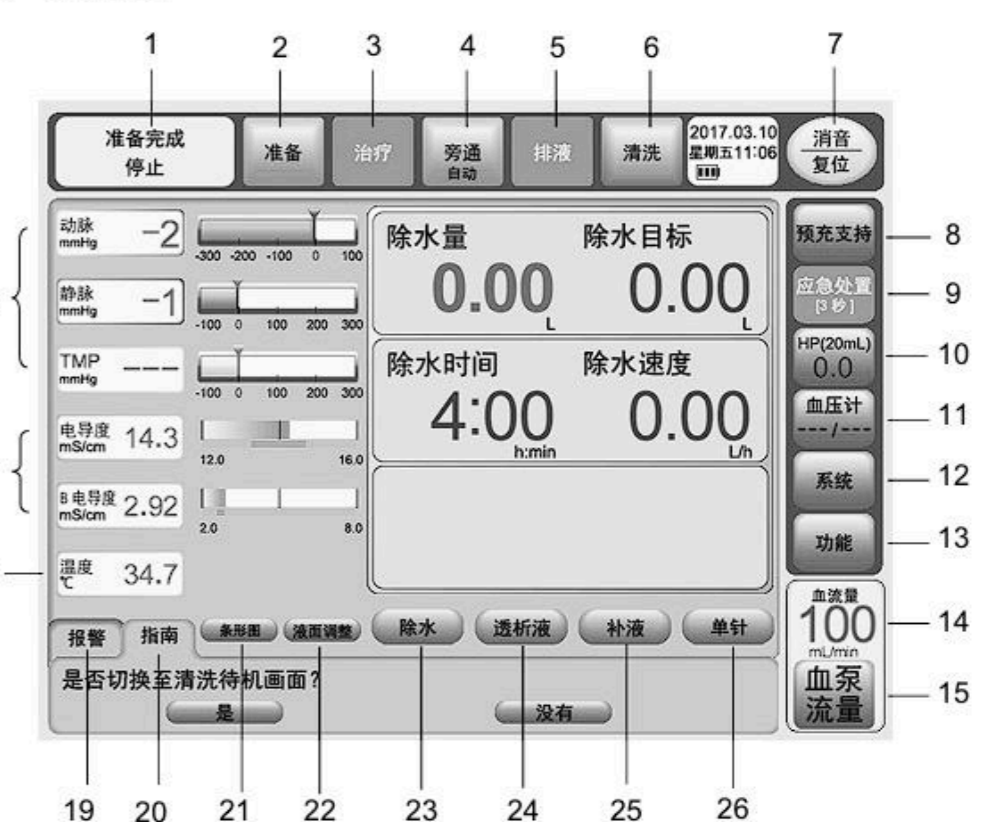

No.	名称	说明
1	运行模式	显示装置的运作状态。
2	准备按钮	移至准备程序。在透析程序时，变更为返回按钮，按下后移至返回程序。
3	治疗按钮	准备完成程序、在回血程序时按下治疗按钮，则移至透析程序。
4	旁通按钮	在准备完成程序、透析程序、回血程序时按下旁通按钮，透析液旁通。
5	除水停止按钮或 排液按钮	在准备程序、准备完成程序、回血程序时按下排液按钮，可进行排液动作。在透析程序时可停止除水。
6	清洗按钮	在准备程序、准备完成程序、回血程序时按下清洗按钮，移至清洗模式。
7	消音/复位按钮	发生报警时，停止蜂鸣器，报警复位。

2.5. 液面水平调整画面



图 2.5 目标除水量设定

3. 屏幕保护程序



图 3 屏幕保护程序

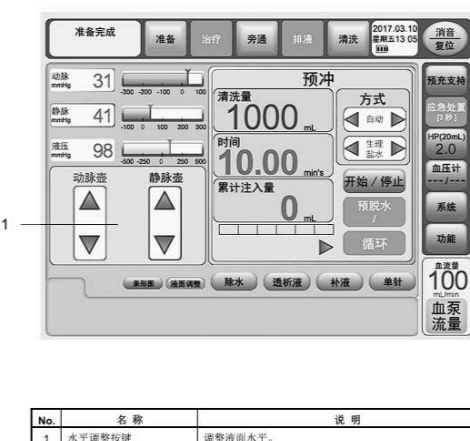
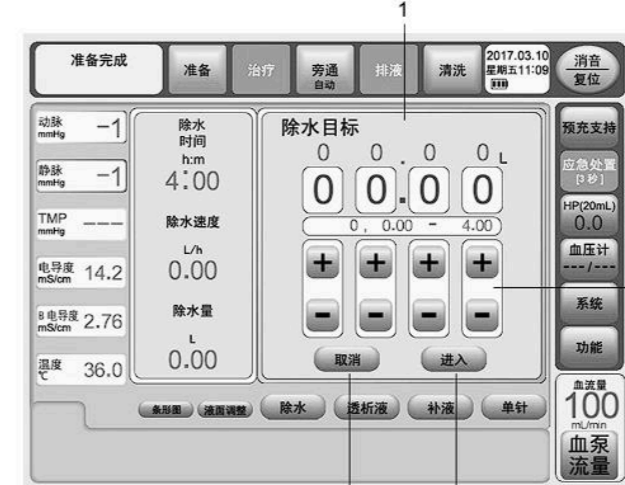

No.	名称	说明
1	目标除水量显示	触摸显示区域后，显示设定数值。
2	十一号按钮	通过十一号按钮，设定数值。
3	取消按钮	取消设定变更。
4	进入按钮	确定设定。

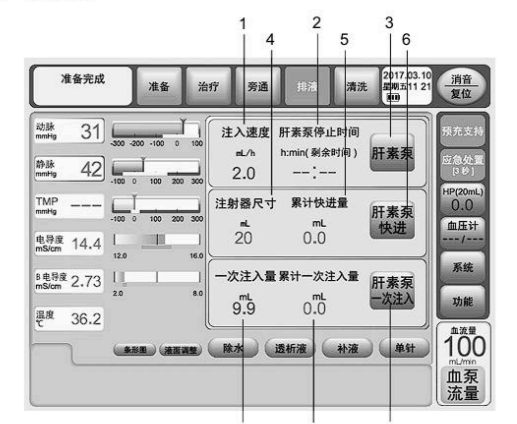

No.	名称	说明
1	注入速度	显示注入速度。
2	肝素泵停止时间	显示肝素泵停止时间。
3	肝素泵流量	触摸显示区域后，可进行设定。
4	肝素泵流量	触摸显示区域后，可进行设定。
5	量计流量	显示量计流量。
6	肝素泵流量	显示肝素泵流量。
7	一次注入量	显示一次注入量。
8	量计一次注入量	显示量计一次注入量。
9	肝素泵一次注入量	显示肝素泵一次注入量。

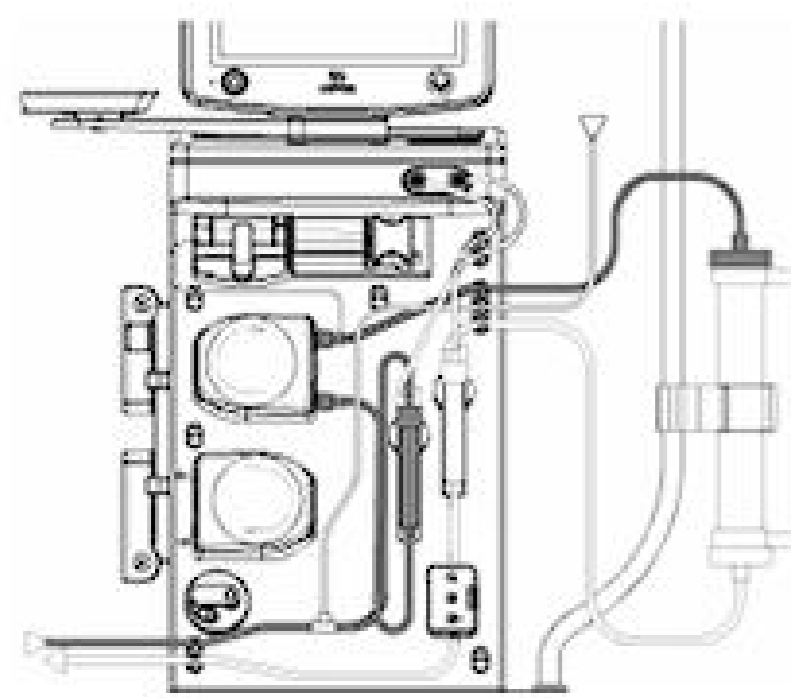

(无 SPR 选配件)

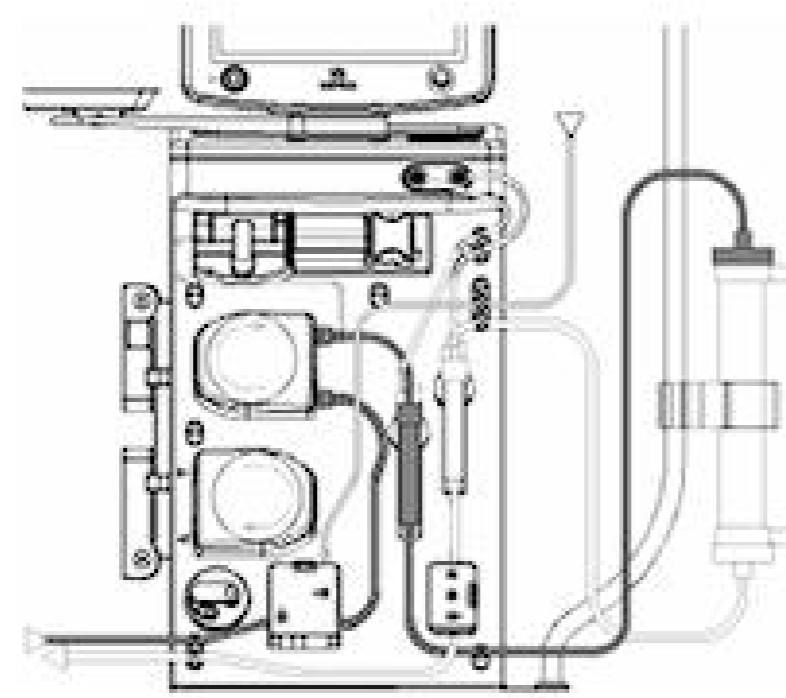

(有 SPR 选配件)

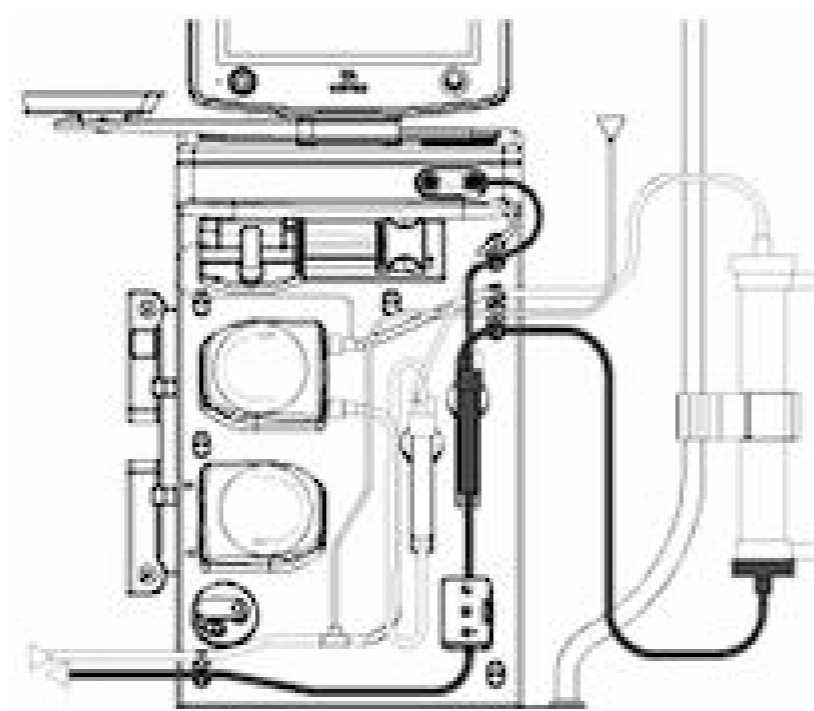

(无 SPR 选配件)

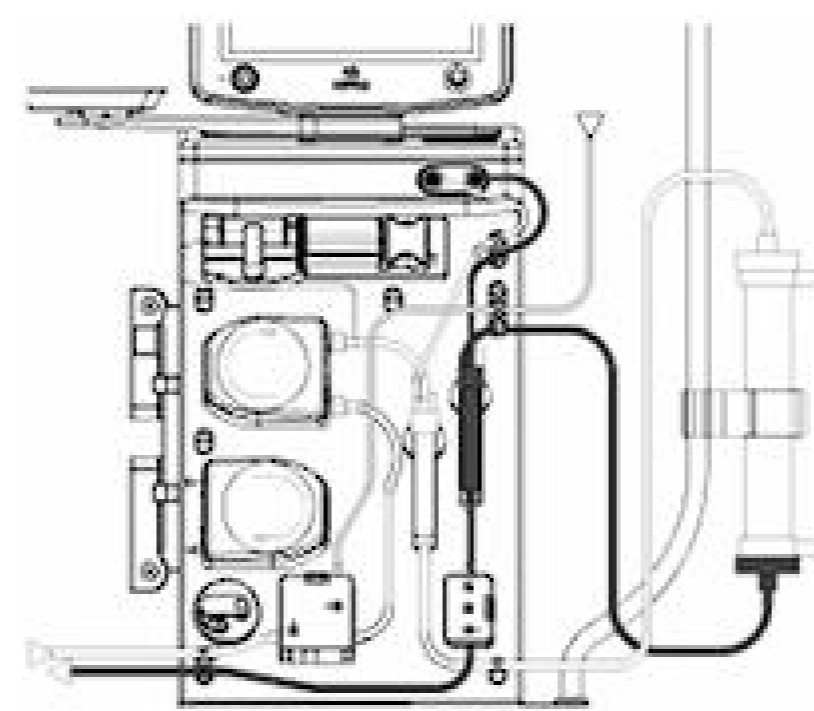

(有 SPR 选配件)

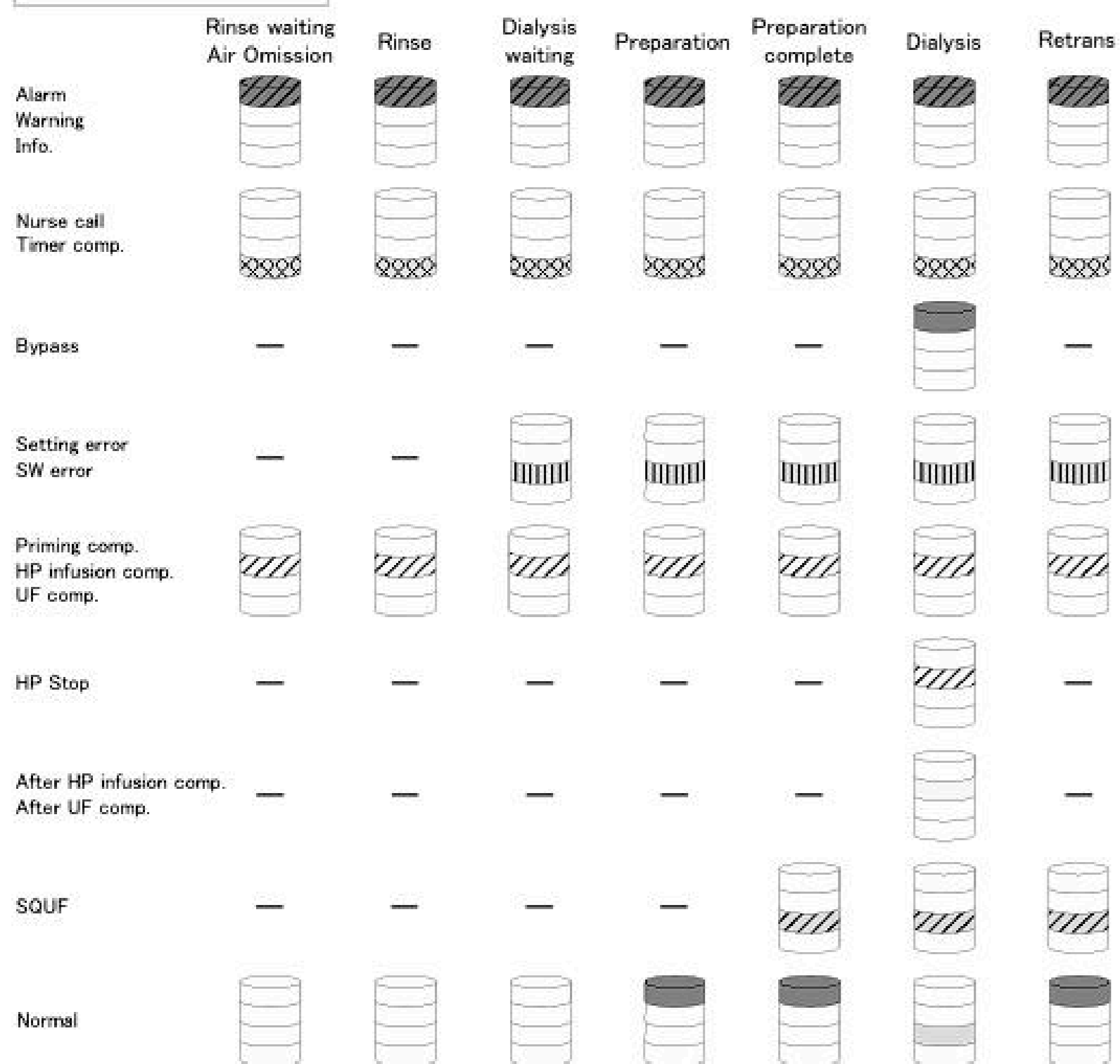
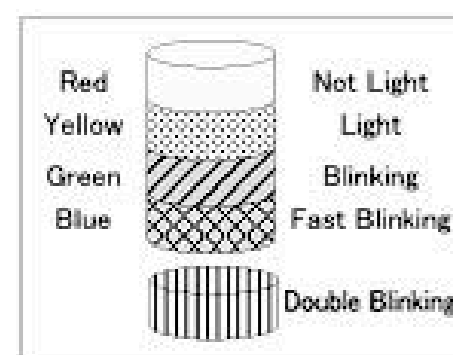
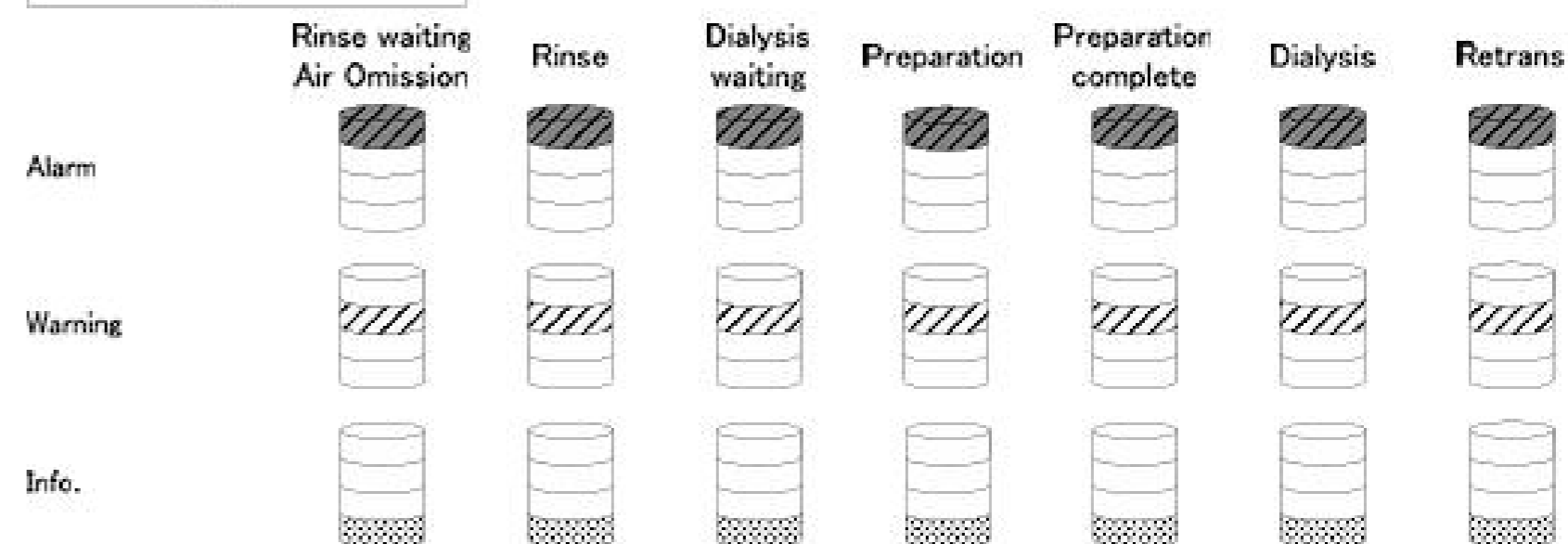
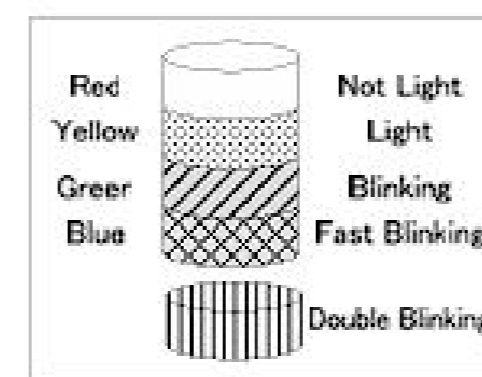

10.2. 透析菜单

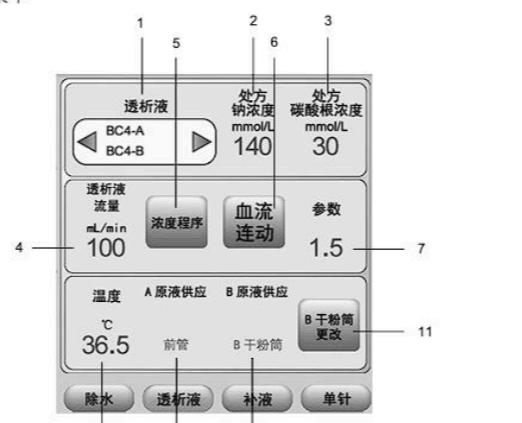

No.	设定项目	初始值	设定范围	设定步骤	选择项目
1	透析液	-	AC1-2, BC1-10	-	可输入产品名称
2	处方钠	系统设定值 - 设定 - 浓度	125 - 160	1	-
3	处方钾	系统设定值 - 设定 - 浓度	24 - 70	1	-
4	透析液流量	系统设定值 - 设定 - 治疗	100 - 800	100	-
5	速度程序	天	-	-	开/关
6	血液流动	天	-	-	开/关
7	系数	系统设定值 - 设定 - 治疗 - 浓度信息	1.0 - 3.0	0.1	-
8	温度	系统设定值 - 设定 - 治疗 - 初始透析液温度	33.0 - 39.0	0.1	-
9	A 报警抑制	系统设定值 - 设定 - 浓度 - 浓度信息	-	-	-
10	B 报警抑制	系统设定值 - 设定 - 浓度 - 浓度信息	-	-	-
11	B 报警抑制 更改 报警	天	-	-	开/关

10.3. 补液菜单

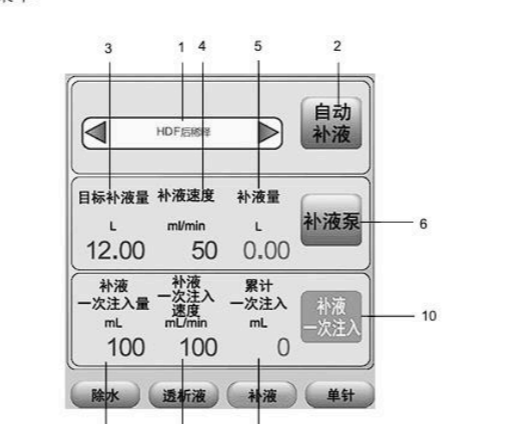

No.	设定项目	初始值	设定范围	设定步骤	选择项目
1	治疗模式	HD	HD, HDF, HDF 后稀释, HP 后稀释, HF 后稀释	-	-
2	自动补液 报警	天	-	-	开/关
3	目标补液量	系统设定值 - 设定 - 治疗 - 治疗 - 初始目标补液量	1 - 720	1	-
4	补液速度	系统设定值 - 设定 - 治疗 - 治疗 - 初始补液速度	10 - 500	1	-
5	补液量	0.0	-	-	-
6	补液报警	天	-	-	开/关
7	补液一次注入量	系统设定值 - 设定 - 治疗 - 治疗 - 补液一次注入量	30 - 500	10	-
8	补液一次注入速度	系统设定值 - 设定 - 治疗 - 治疗 - 补液一次注入速度	10 - 500	10	-
9	累计一次注入	0	-	-	-
10	补液一次注入报警	天	-	-	开/关

10.4. 单针菜单



No.	设定项目	初始值	设定范围	设定步骤	选择项目
1	单针 报警	关	-	-	开/关
2	单针高压改变点	200	100 - 350	10	-
3	单针低压改变点	50	20 - 150	10	-
4	单针最小吸入时间报警	20	5 - 30	1	-
5	单针最小吸入量	10	天, 5 - 100	1	-
6	有效血流量	0	-	-	-
7	平均吸入量	0	-	-	-

-Kt/V 设定

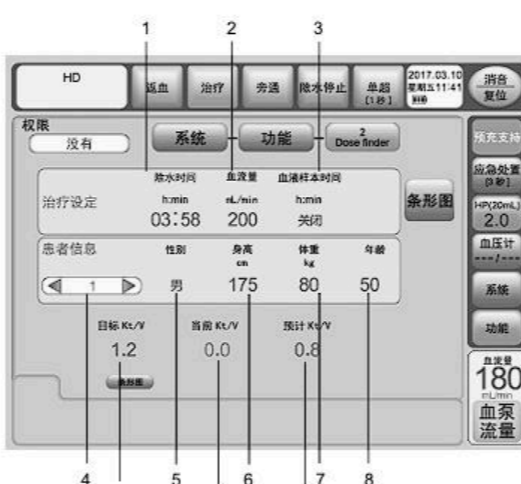

No.	设定项目	初始值	设定范围	步骤
1	剩余治疗时间	系统 - 设定 - 治疗 - 除水 - 初始治疗时间	0.00 - 24.00	0.01
2	血流量	200	10 - 600	5
3	血液样本时间	天	00.01 - 24.00	0.01
4	患者信息	1	1 - 6	1
5	性别	男	男 - 女	-
6	身高	175	50 - 250	1
7	体重	80	20 - 300	1
8	年龄	50	1 - 120	1
9	目标 Kt/V	1.2	0.5 - 2.0	0.1
10	当前 Kt/V	-	-	0.1
11	预计 Kt/V	-	-	0.1

- Kt/V 图表

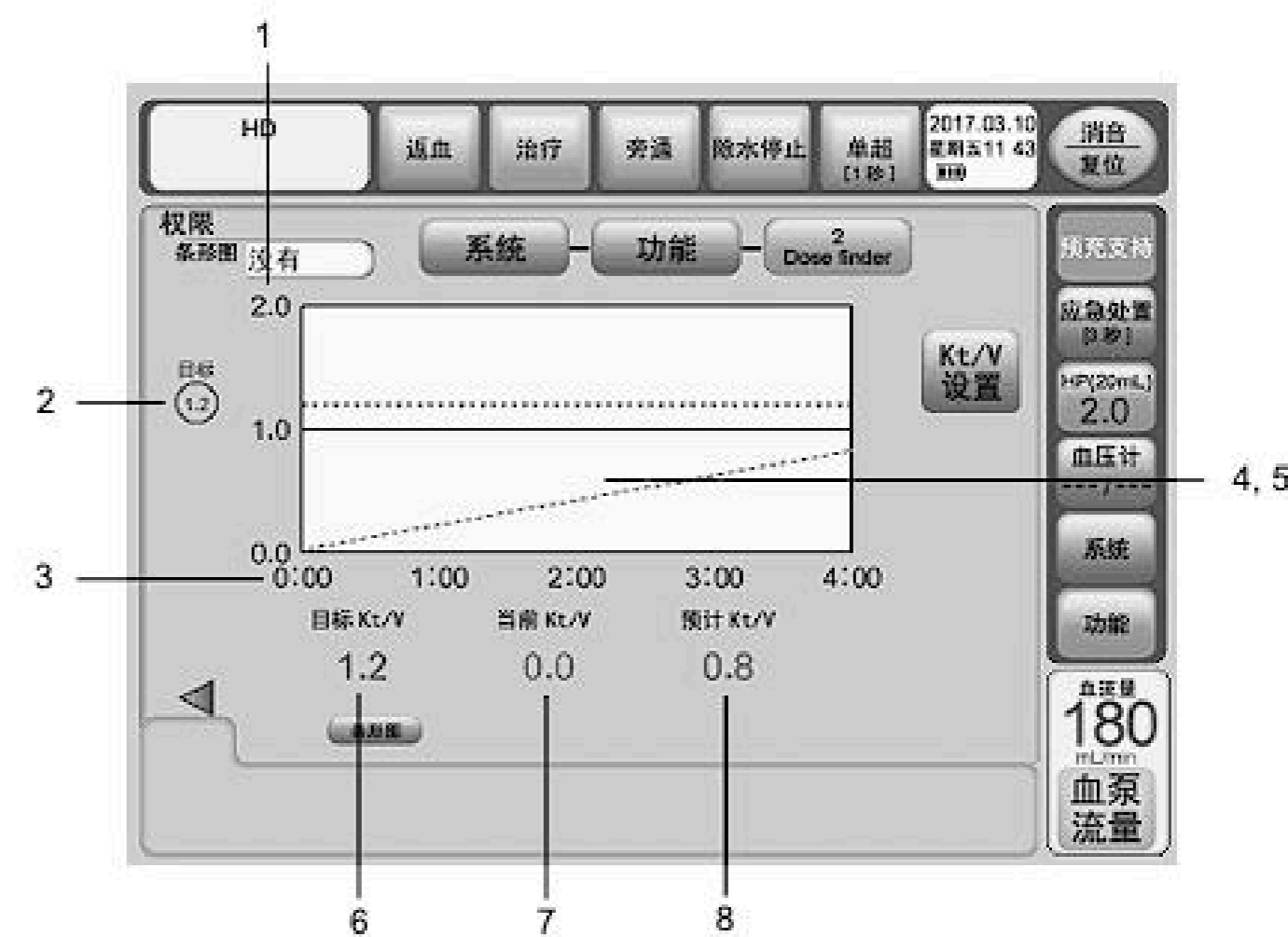

No.	设定项目	初始值	设定范围	步骤	选项
1	纵轴: Kt/V	-	-	-	-
2	目标 Kt/V 横线	-	-	-	-
3	横轴: 时间	-	-	-	-
4	预计 Kt/V 图表 (虚线)	-	-	-	-
5	当前 Kt/V 图表 (实线)	-	-	-	-
6	目标 Kt/V	-	0.0 - 2.0	0.1	-
7	当前 Kt/V	-	-	-	-
8	预计 Kt/V	-	-	-	-

Instrument disassembly diagram

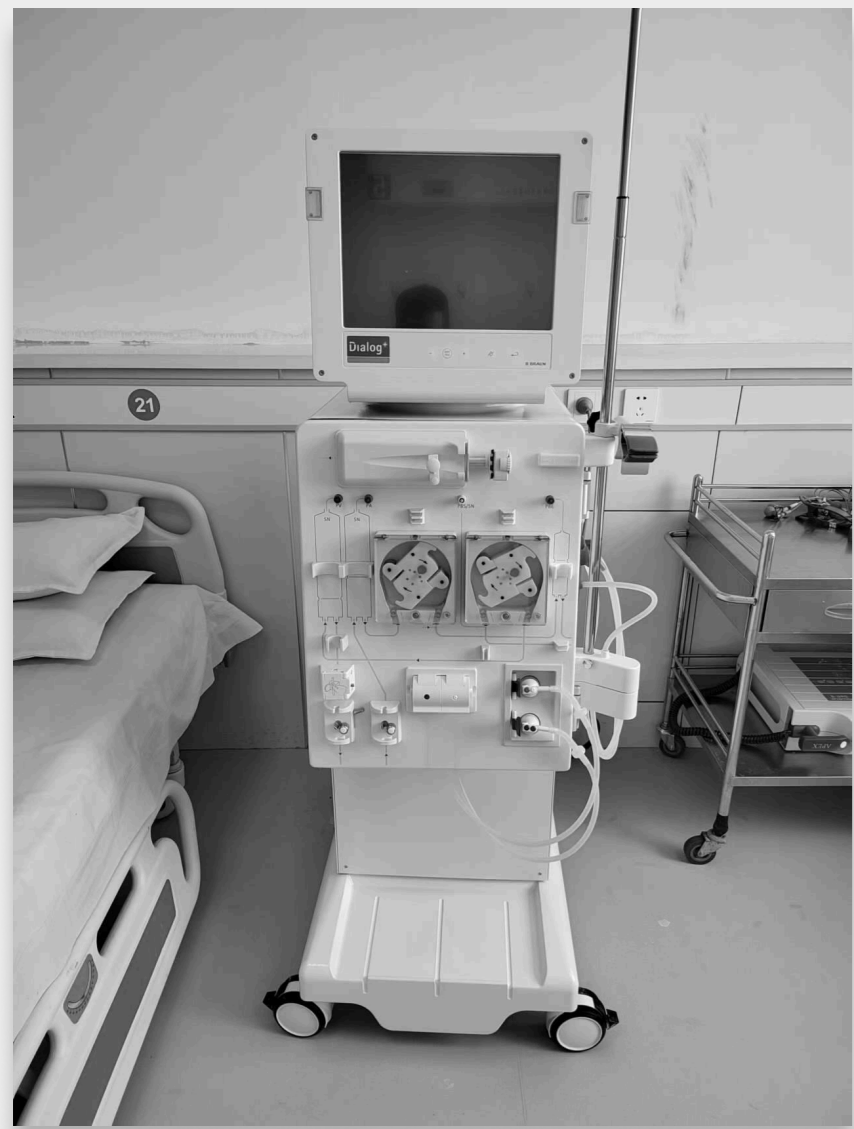

I have someone in my family who runs a kidney dialysis hospital, so I've had the opportunity to dismantle the physical object.

After this I had a good understanding of the construction of a renal dialysis machine and how it works

Interview-Renal Dialysis Instrumentation Engineer

As a dialysis equipment engineer, do you think it is possible to convert a dialysis machine into a blood circulation system for organ preservation?

Dialysis machines and organ preservation systems operate on similar principles, both requiring stable circulation and regulated conditions. Therefore, the pump, temperature control, and filtering modules of a dialysis machine could serve as the foundation for conversion.

It sounds like the technical conversion between the two is feasible, but what challenges might it face?

The main challenge is their differing needs. Dialysis machines focus on waste removal, whereas organ preservation requires oxygen, nutrients, stable temperature, precise flow and pressure control, and strict sterility. While conversion is possible, significant optimization is needed.

So what changes do you think such a device would bring to organ transplantation?

If successfully developed, this device will improve organ preservation quality and duration, offering greater flexibility for transport and transplants. By mimicking human blood circulation, it maintains optimal organ function before transplantation and may even repair marginal organs, marking a breakthrough in the field.



Tec: How to realise

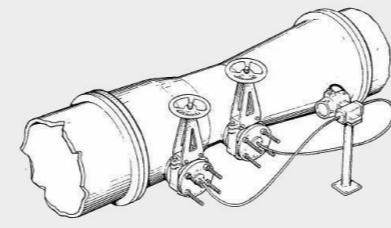

Equipment Adaptation

Ensure the machine provides adjustable flow and pressure; replace tubing for organ perfusion.



Flow and Pressure Regulation

Adjust pump settings for low-pressure perfusion to prevent vascular damage. Monitor flow to meet organ requirements.



Temperature Control System

Add a unit to maintain perfusion fluid at 4°C-37°C.

Use sensors to monitor fluid temperature in real time.



Oxygenation and Gas Exchange

Use an oxygenator for oxygen support. CO₂ levels to maintain a physiological environment.



Perfusion Fluid Replacement

Use organ preservation fluids (e.g., UW, HTK). Remove filters to retain essential components.



Monitoring System

Track flow, pressure, temperature, and oxygen levels; trigger alarms for deviations.

DESIGN GOAL

DRONE

Efficient Transport: Optimized flight performance ensures organs reach their destination in minimal time.

Real-Time Monitoring: Integrated sensors and communication modules provide live updates on location, flight status, and storage conditions.

Safety and Stability: Multiple redundant systems guarantee stable flight even in adverse weather or emergency situations.

Automated Operation: Automated takeoff, landing, and route planning reduce delays caused by manual intervention.

ORGAN STORAGE BOX

Precise Temperature Control: Maintains 2-8°C with high-precision technology.

Integrated Circulation: Biomimetic micro-circulation extends preservation time.

Sterile Environment: Medical-grade, sealed design prevents contamination.

Real-Time Monitoring: Sensors track key metrics and upload data via drone.

Shock Protection: Anti-vibration structure minimizes in-flight damage.

SYSTEMS INTEGRATION

Power and Load Balance: Optimize the drone's power system and structure based on the storage container's weight and dimensions to ensure stable flight.

Data Transmission and Alerts: The storage container and drone system share real-time data; if storage conditions deviate from set standards, the system automatically triggers alerts and adjusts parameters.

Endurance and Efficiency: Designed for long-distance transport, the system incorporates replaceable batteries or rapid charging to maximize efficiency.

INTENDED EFFECT

Achieve ultra-fast transport of organs, maximise the preservation time window of organs and increase the success rate of transplantation.

Provide a stable and safe storage environment, especially for the transport of precious organs (e.g. heart, liver) with all-round protection.

Reduce transport costs through intelligent and automated technology, bringing more popular solutions for organ transplantation.



ADDING NEW FEATURES TO MAPS FOR PATIENT CONVENIENCE

First research Practical application : London

Hospitals qualified to perform organ transplants are located in the suburbs, and drone operations in this area will not affect the daily lives of most residents

Each hospital will have a dedicated drone system, forming a seamless network, similar to a shared bike system for healthcare.

These drones, like ambulances, are part of a unified national infrastructure.

This centralized approach, exemplified by the NHS in the UK, ensures standardized, regulated, and transparent organ transport. Relying on private operators risks oversight loss and unethical practices, such as organ trafficking.

A national framework guarantees accountability and safeguards patient welfare.

YOU CAN SEE HOW MANY DRONES ARE ON STANDBY AND IN OPERATION

TRANSPORT PROCESS



SURGERIES

Removal of the organ donor's organ in the operating theatre for chemical processing



TASK INITIATION

The organ is placed in a temperature-controlled box with monitoring

Then loaded into the drone's cargo hold.

TAKE-OFF AND FLIGHT

Takeoff: The control center launches the drone and sets the flight path.

Monitoring: GPS tracks position, and the system monitors storage conditions. Obstacle avoidance manages buildings, birds, and other objects.



LANDING & HANDOVER

Landing: The drone lands on the designated helipad.

Handoff: The medical team verifies the organ's condition and transports it to the operating room.



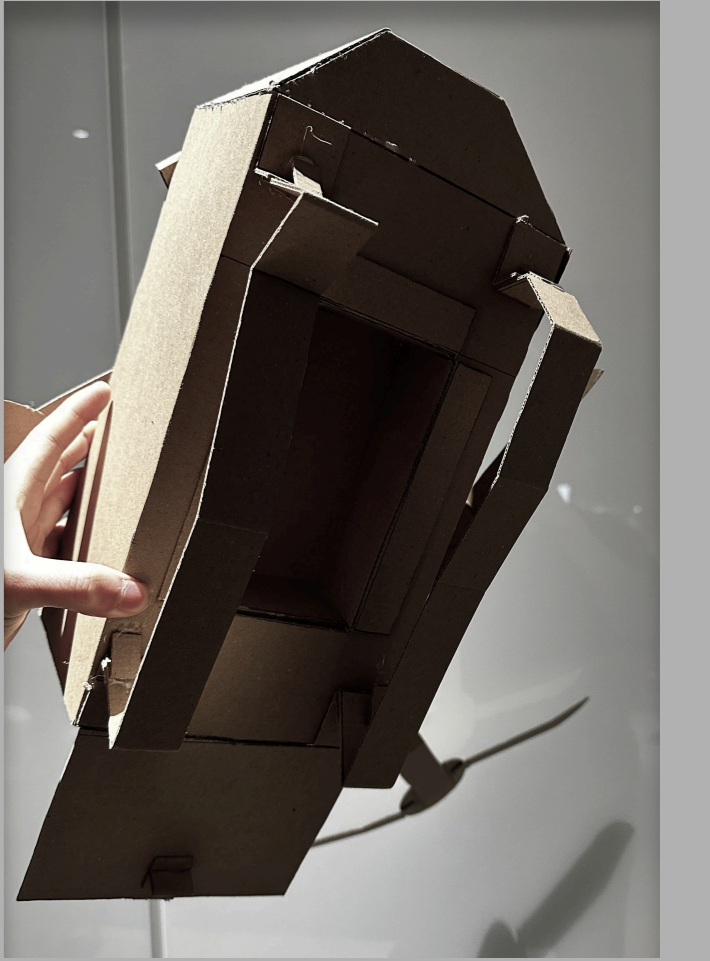

prototype



AI TOOLS: MID JOURNEY

Chosen Idea

Assist me with external form design

Design Upgrade

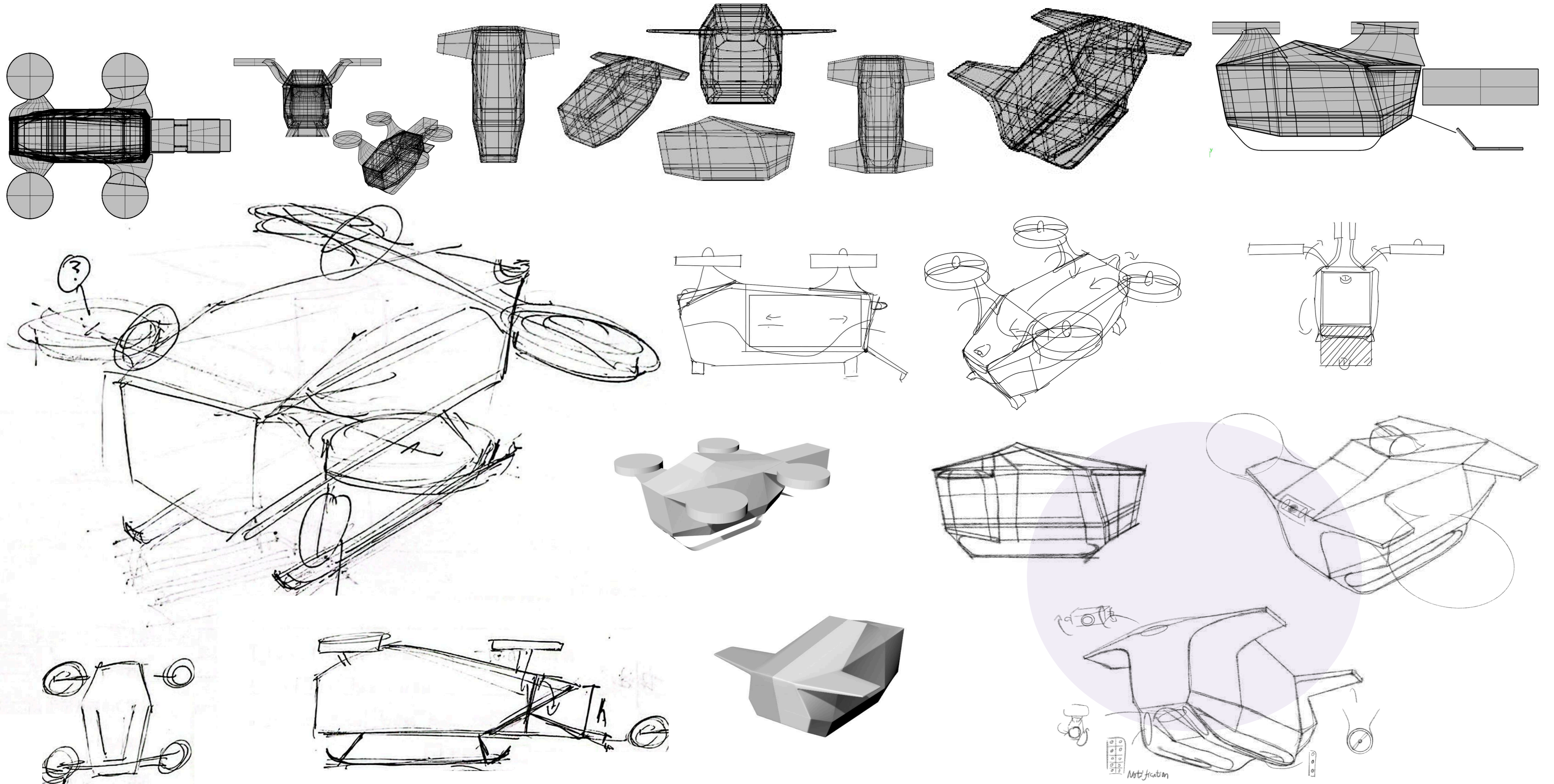

CAD-Time Line

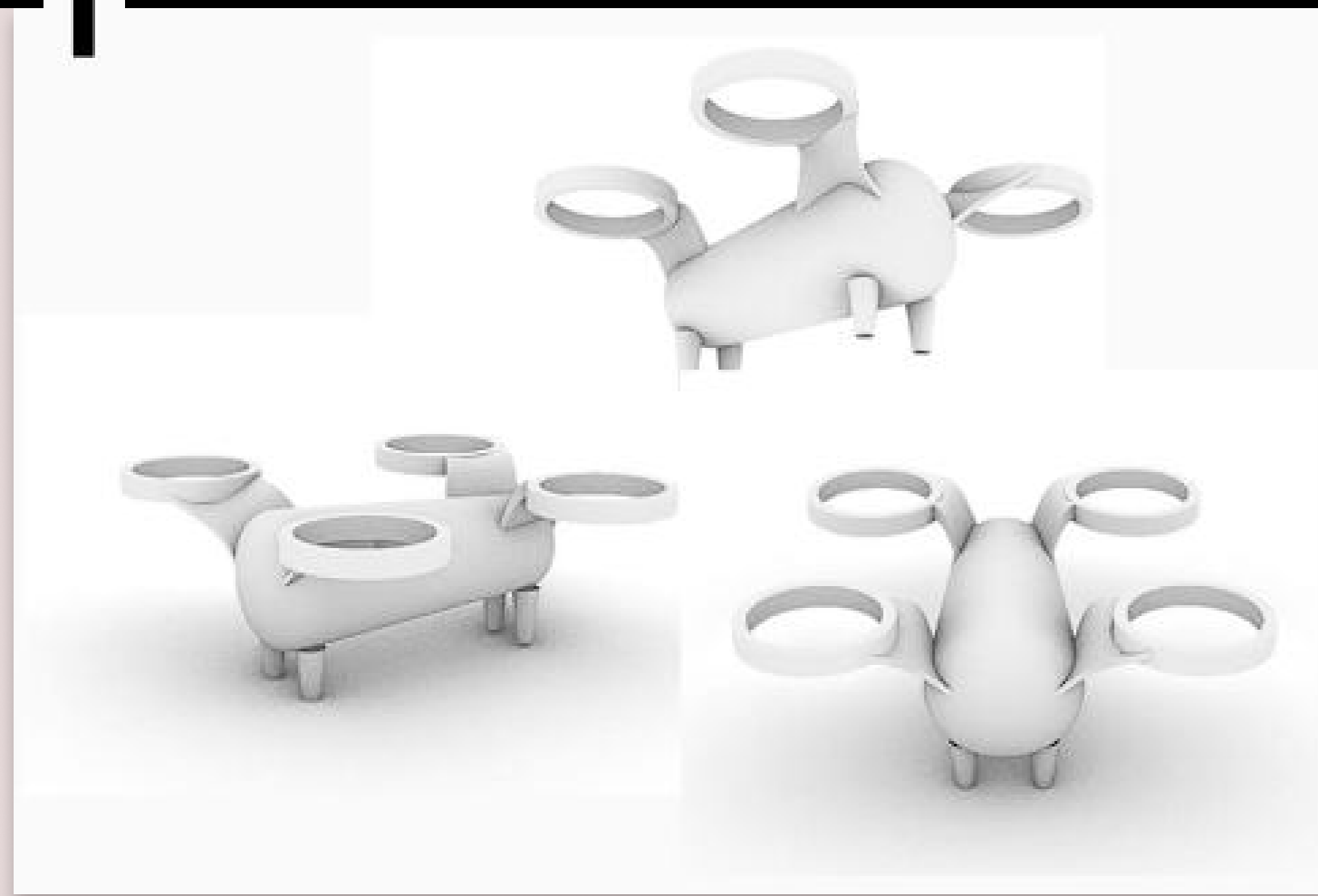

Styling from Direction #3. Didn't think of drone transport at the time.

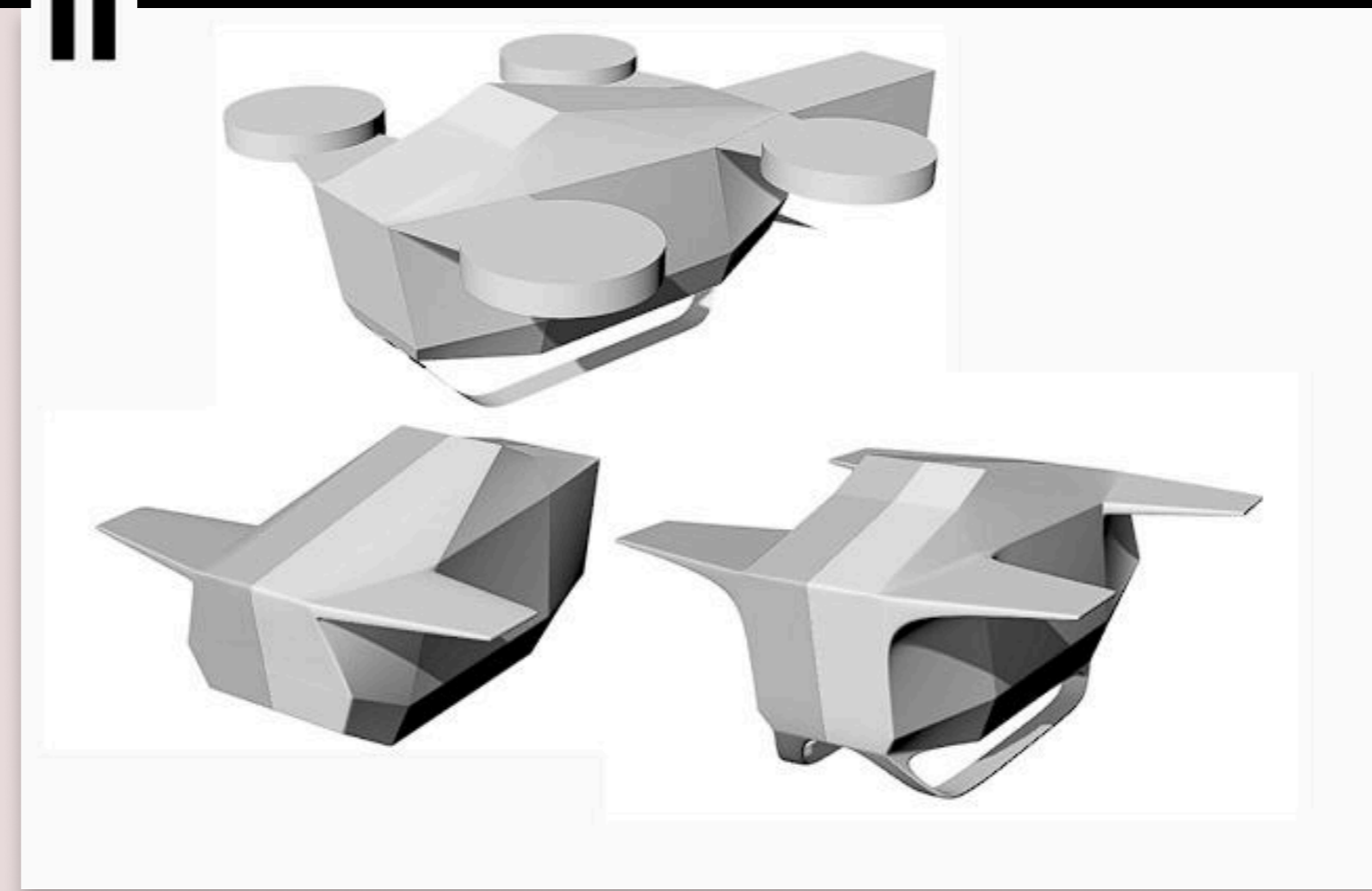

Select Direction#1 for design and start finalising the external structure.

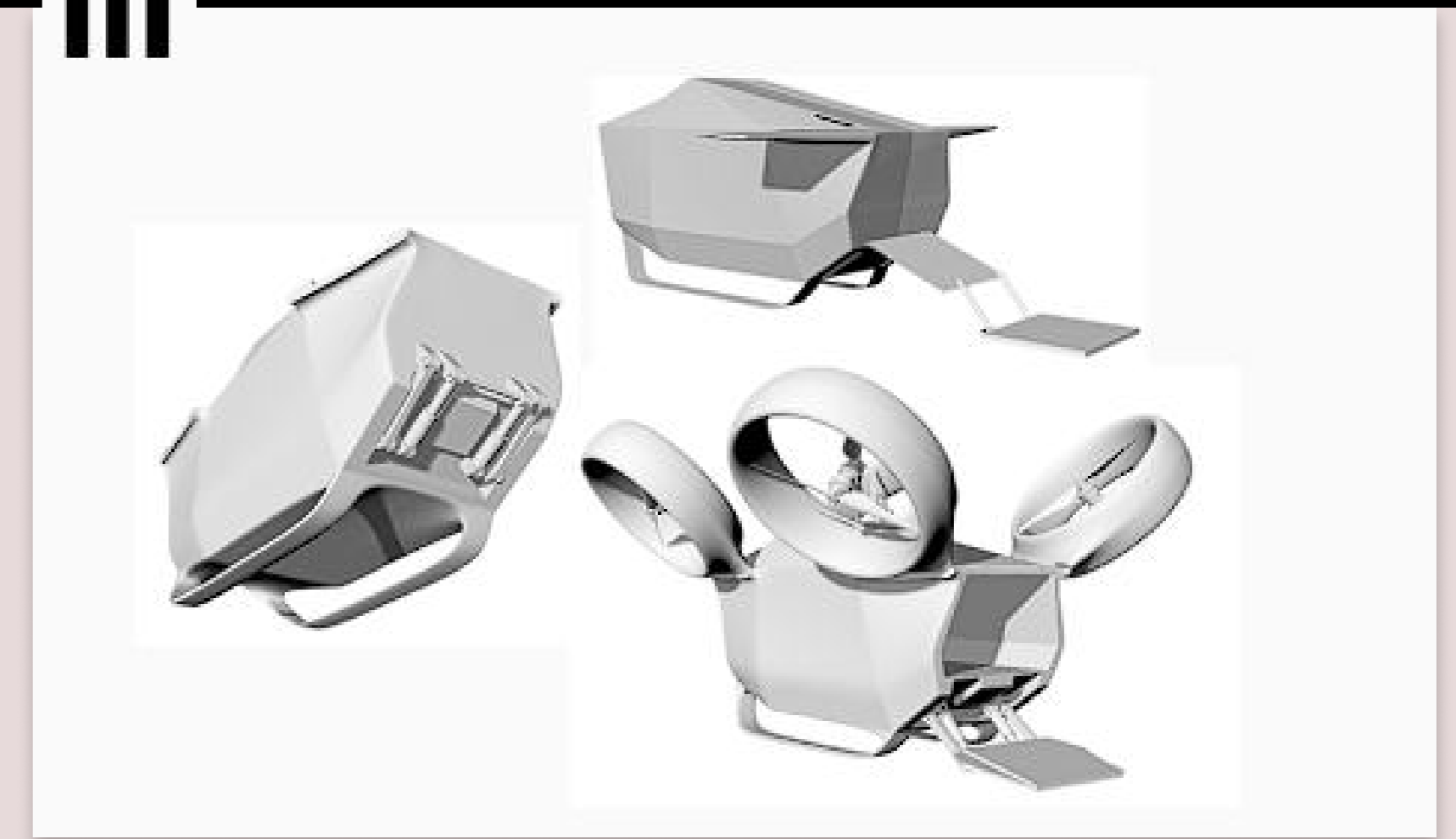

Begin to think about carrying methods, how to place storage boxes

On the next page there will be more detailed information about the structure, and my thought process

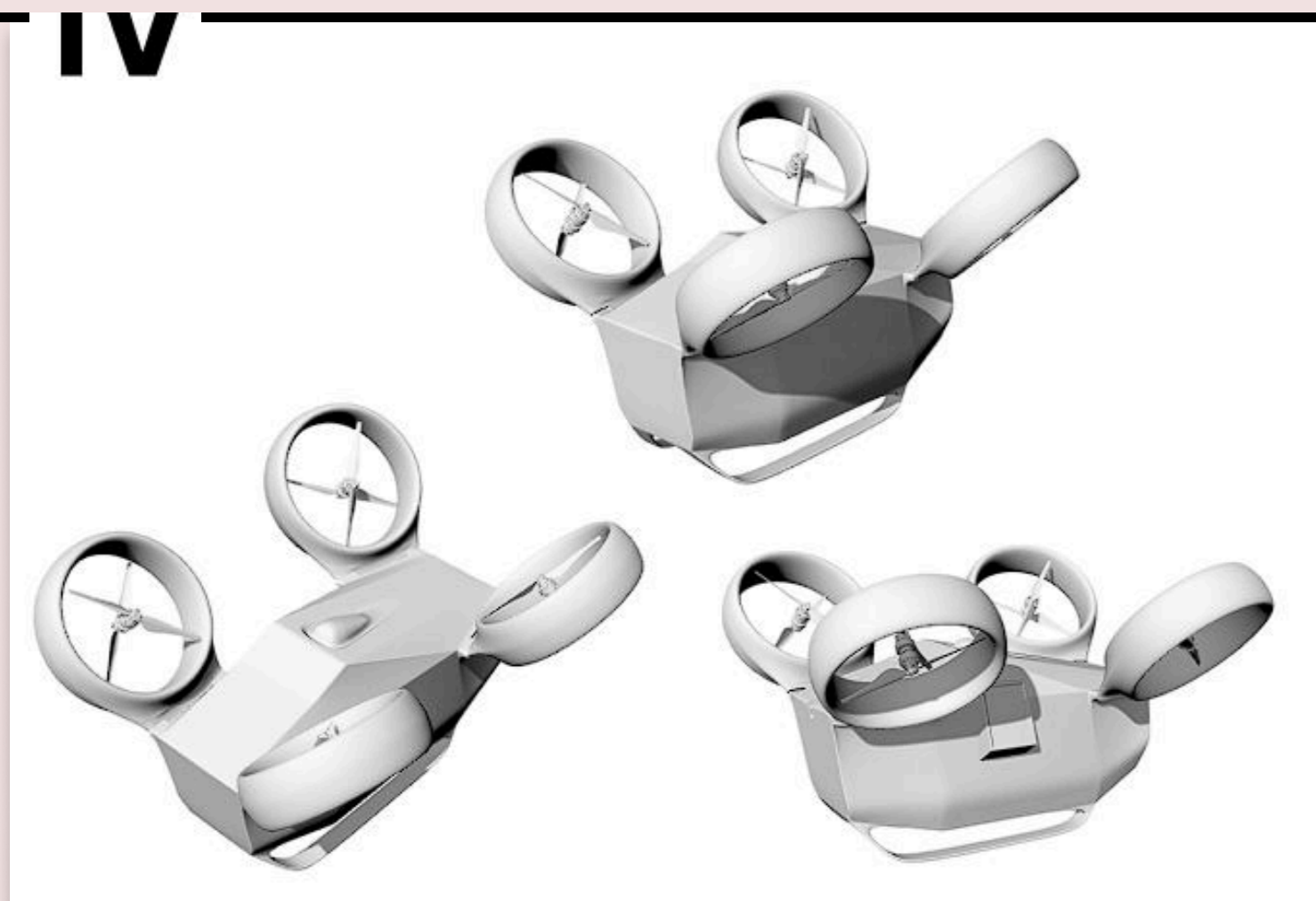

Beginning to add components to the exterior to increase functionality and interactivity

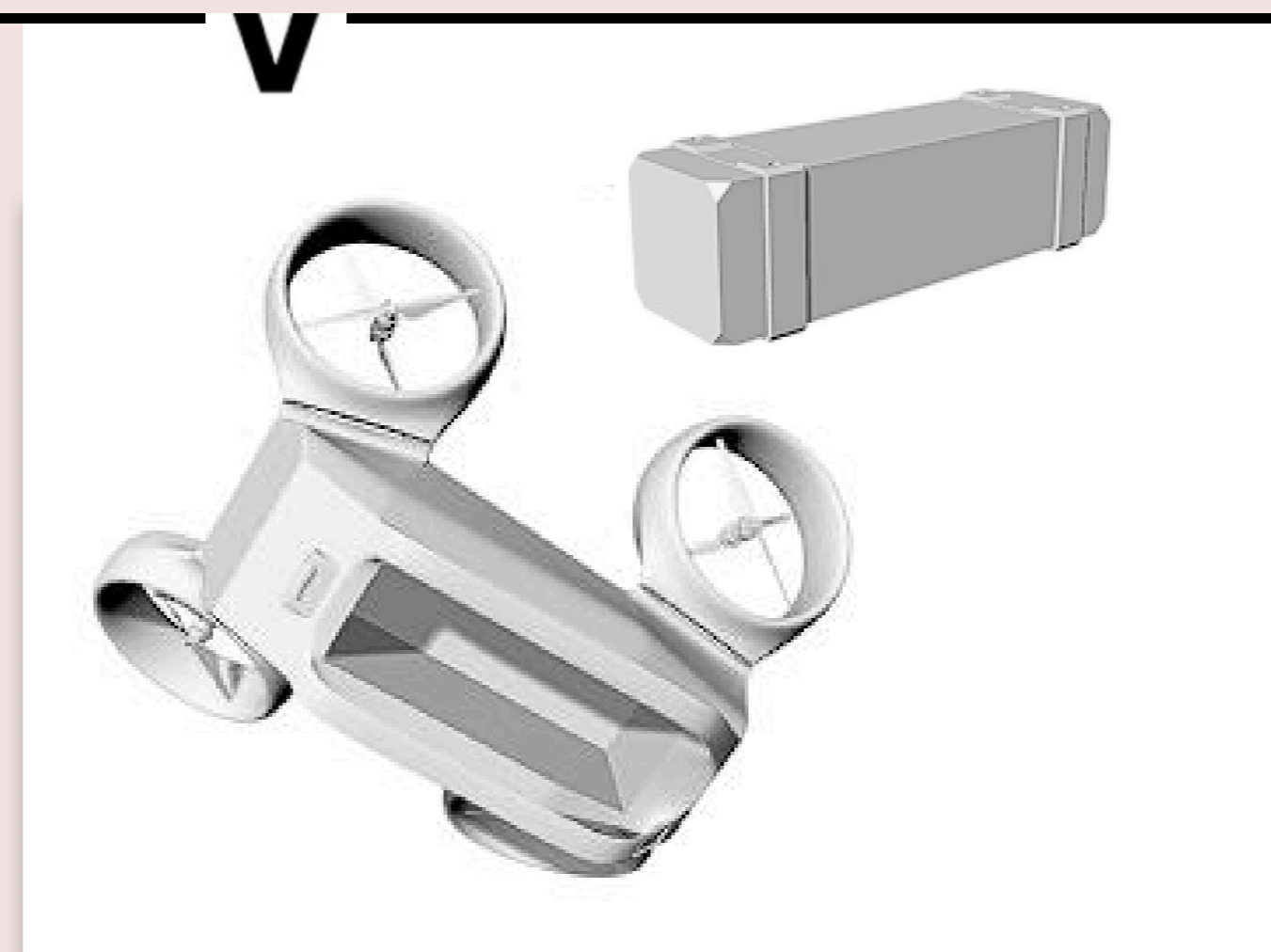

A different type of carrier ensures that no human intervention is required

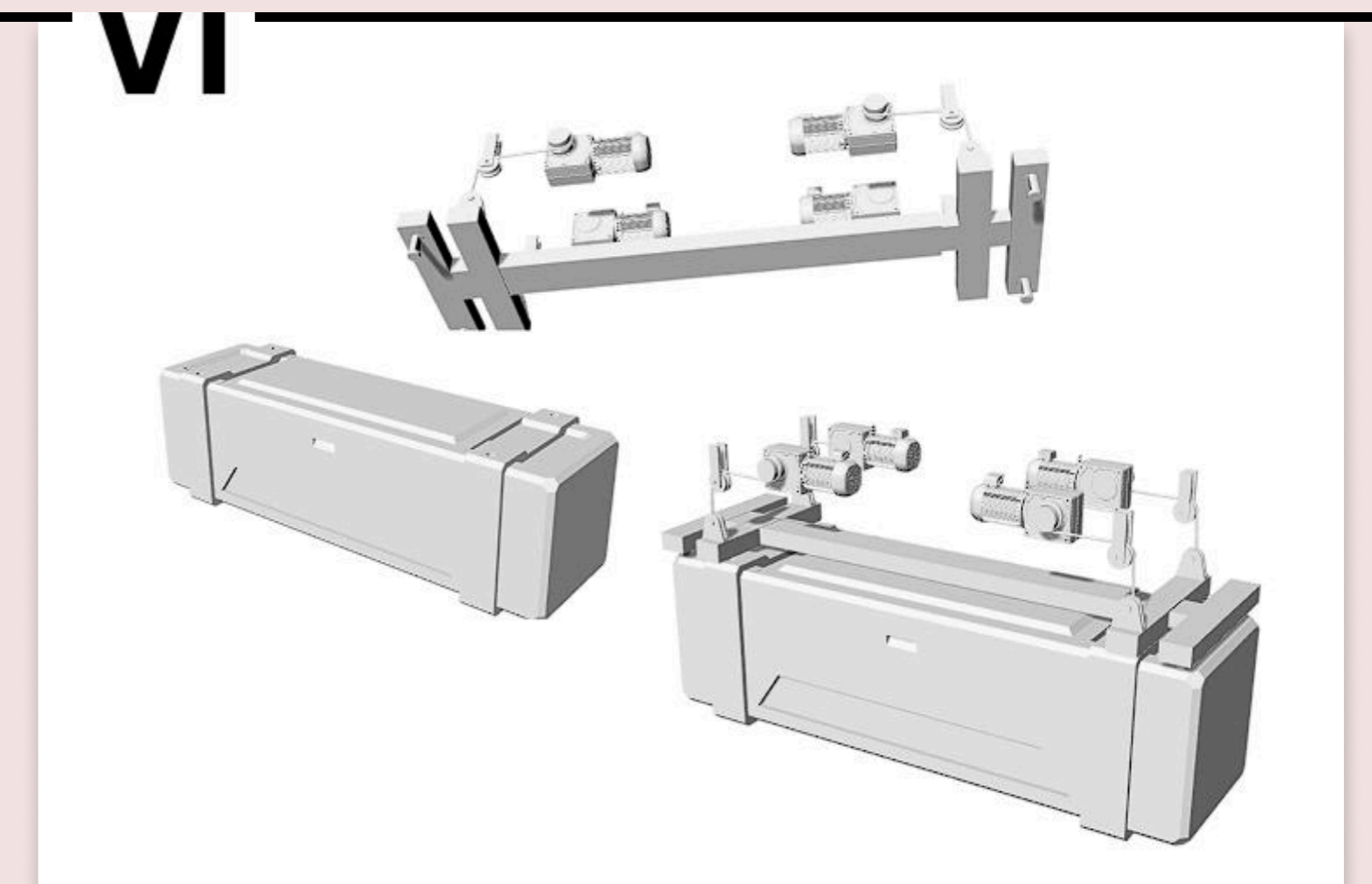

Storage box design, how to fix a storage box to a drone

Design process for storage tank installation

Abandoned case

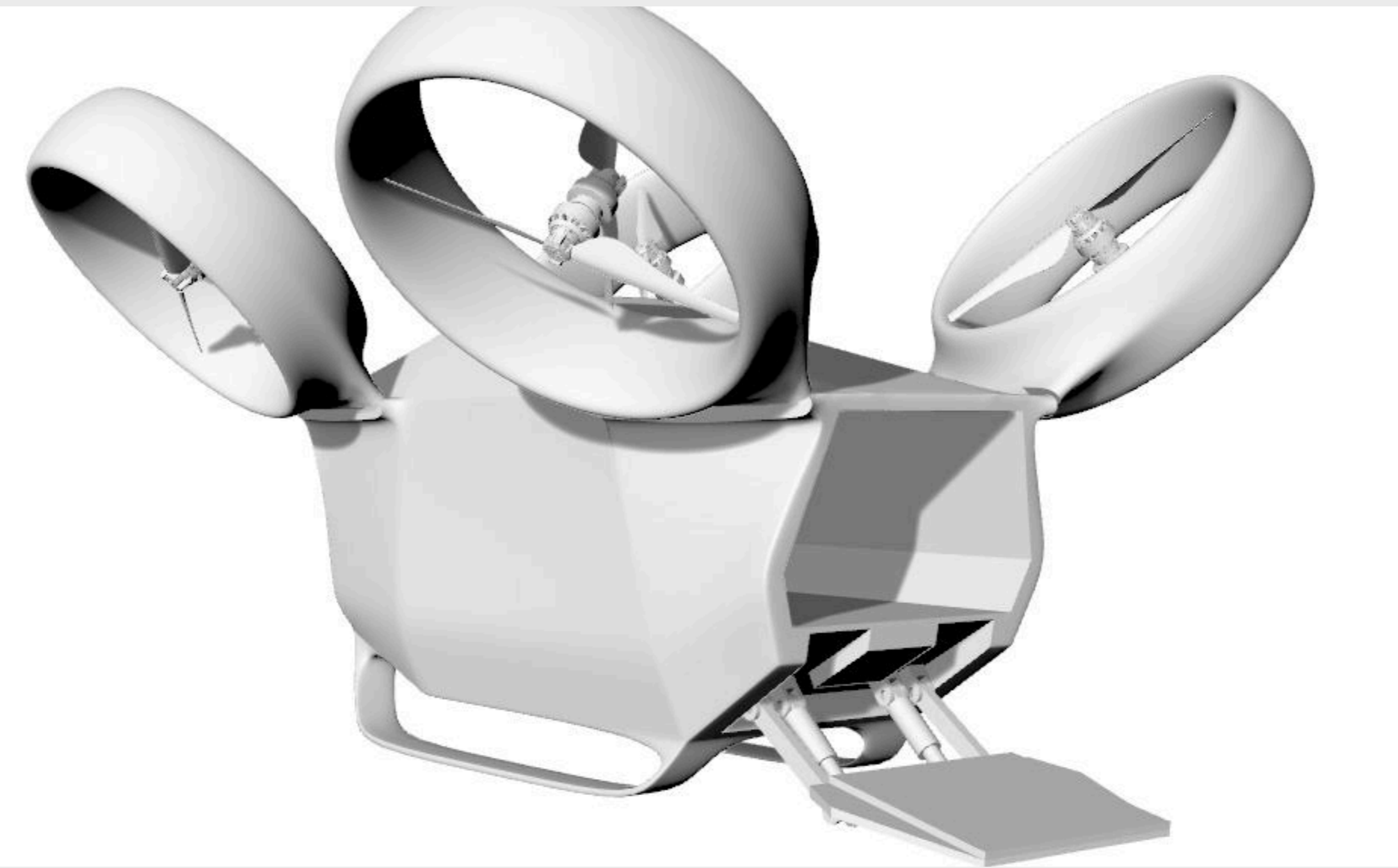

Inspired by cargo trucks, which often carry heavy loads

There is a hydraulic structure at the back of the compartment that lifts the loads to put them inside.

But since the loading and unloading process still requires the presence of a worker, I eventually abandoned the idea

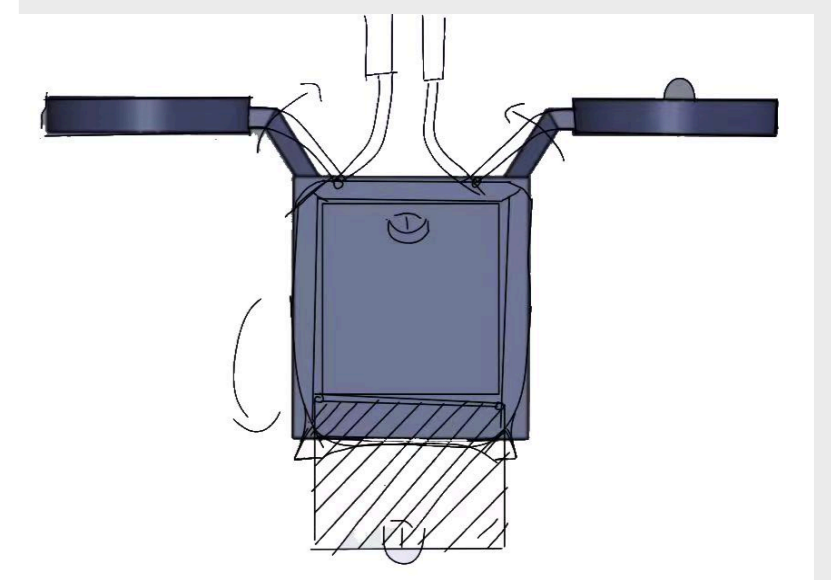
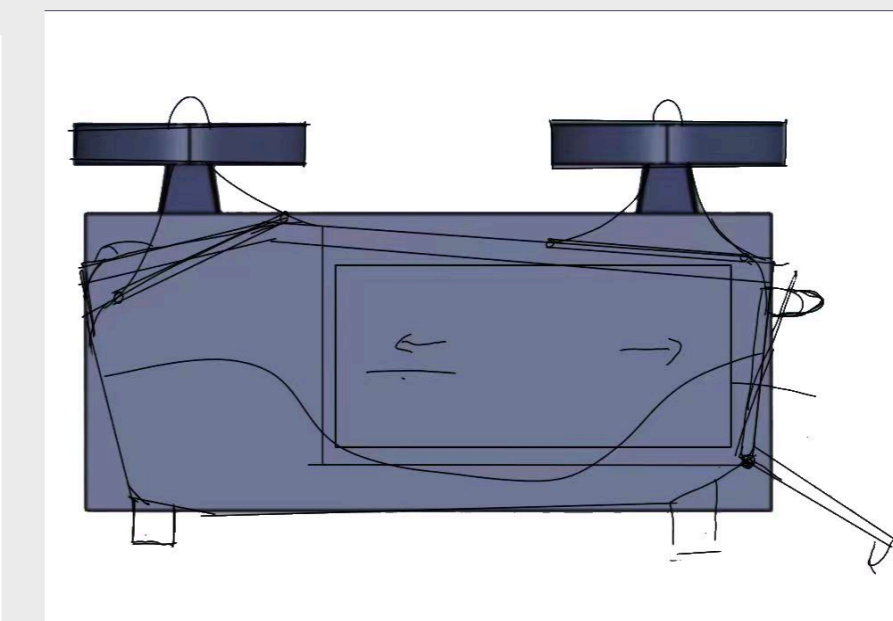
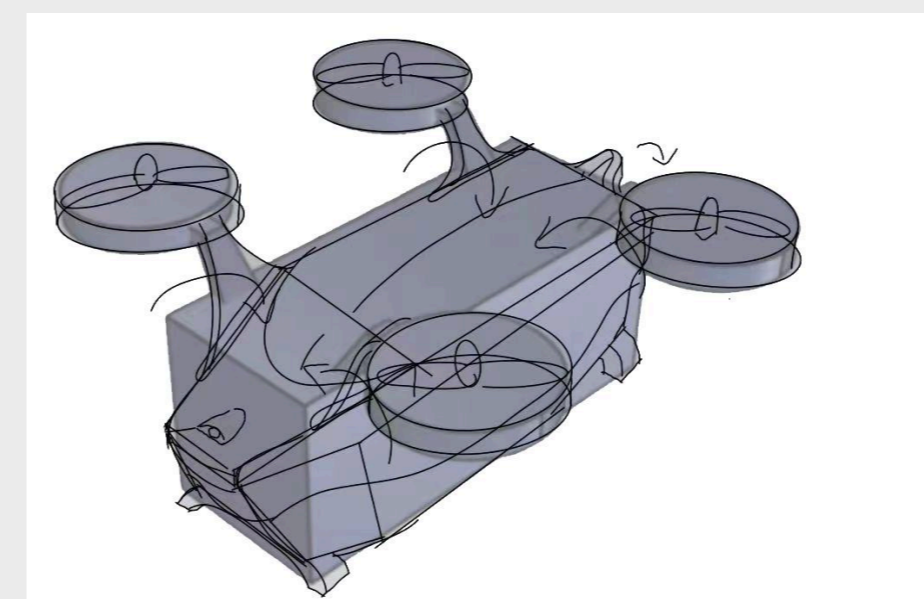
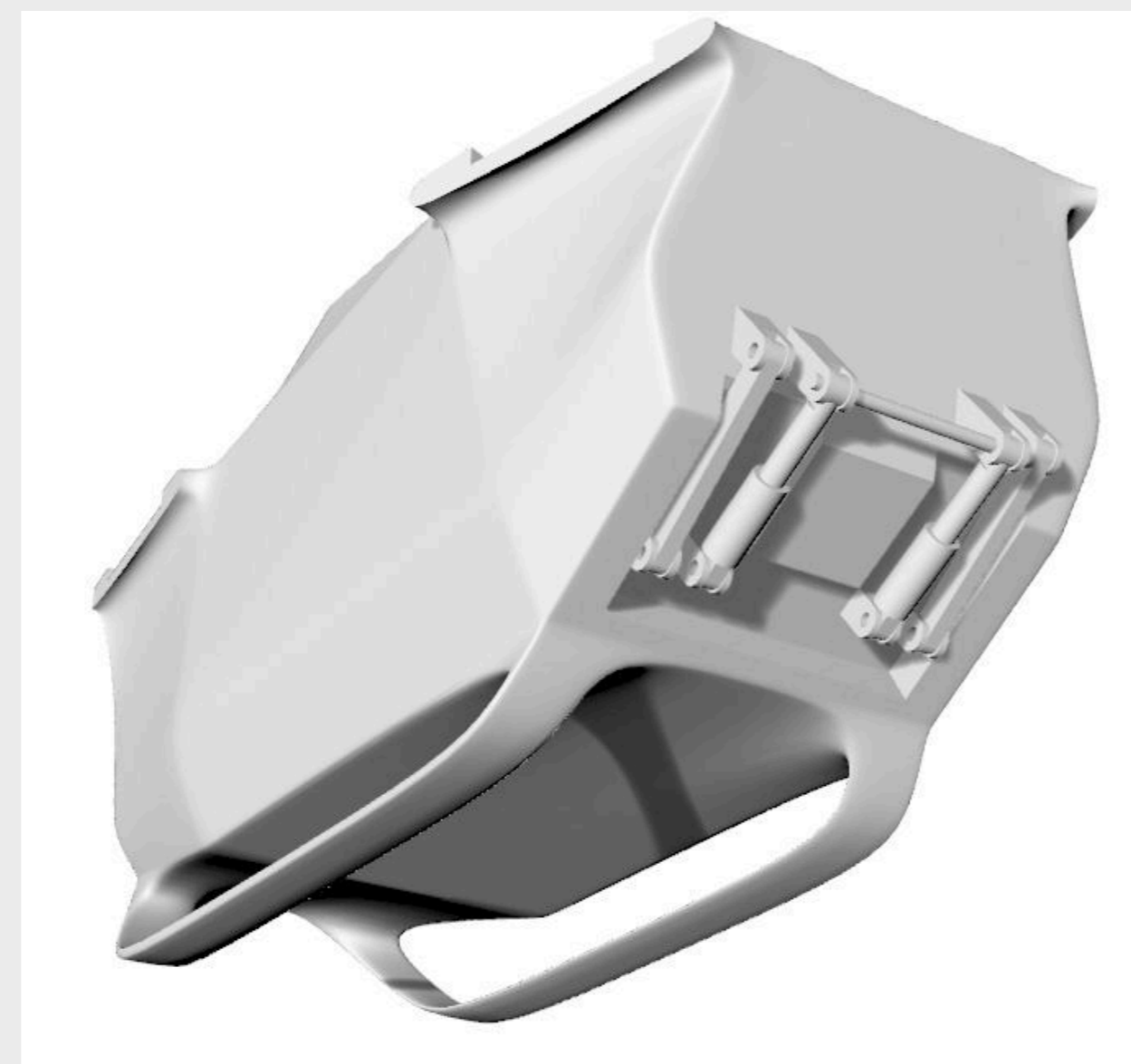

Blueprints

Design process for storage tank installation

Final programme

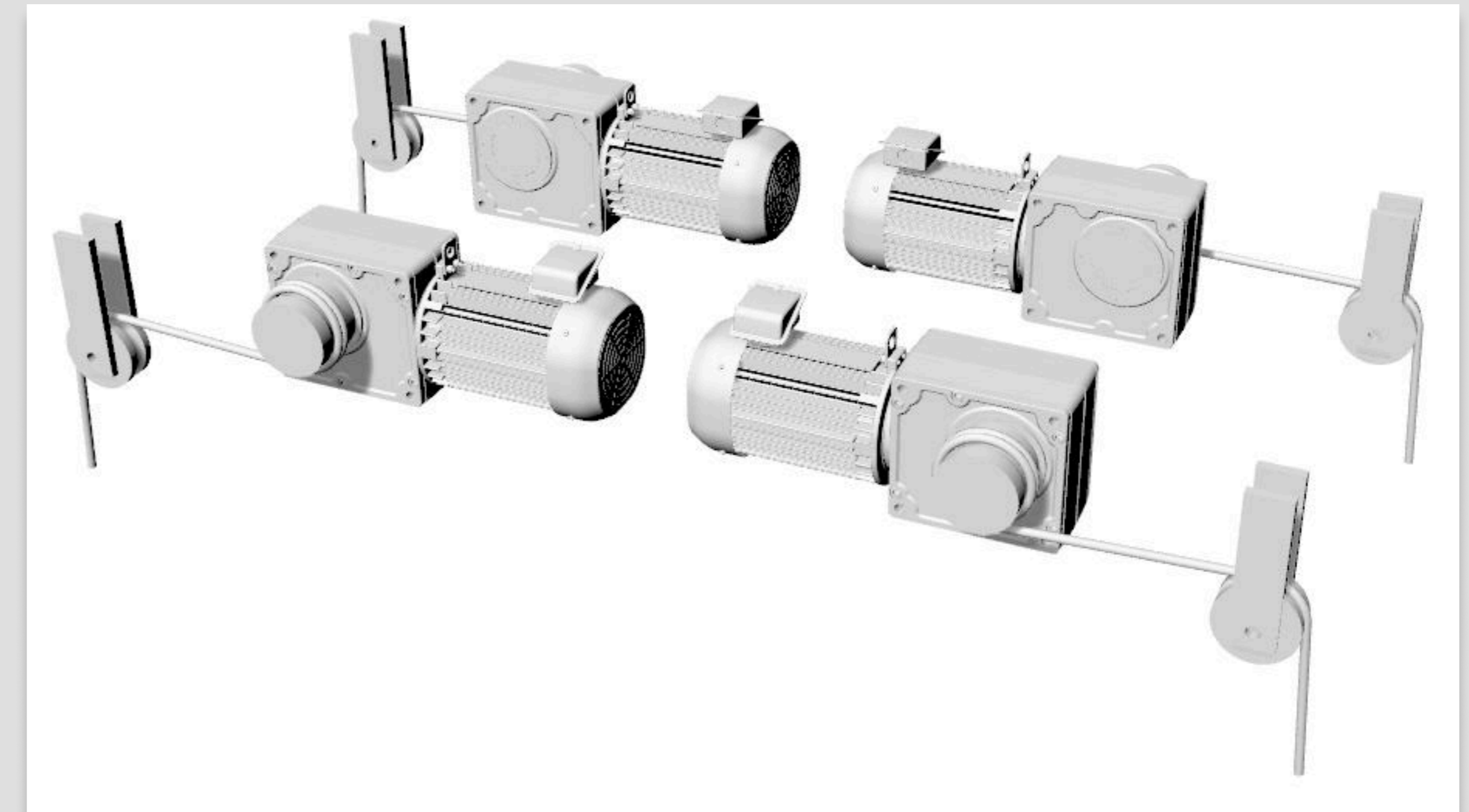

The motor controls the lifting and lowering of the rope so that the clamps can hold the case in place

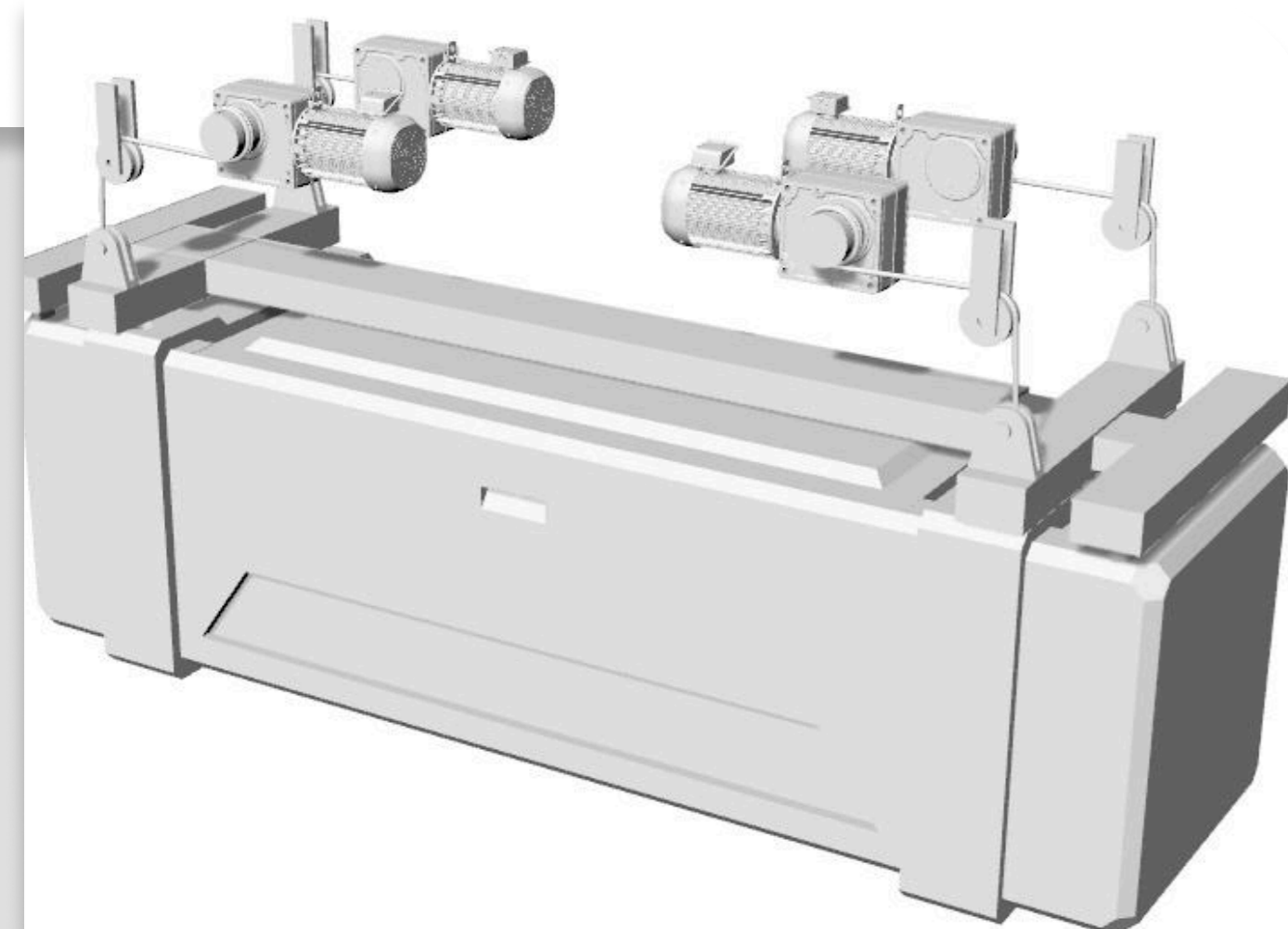

Lifting and lowering structure for loading and unloading of goods without manual labour

As drones cannot carry people, getting workers on site seems difficult and can be labour intensive, and these costs will be borne by the patient

This structure makes loading incredibly easy and truly automated and unmanned, while doing so in a way that is less stressful for the patient

Storage tank lifting system

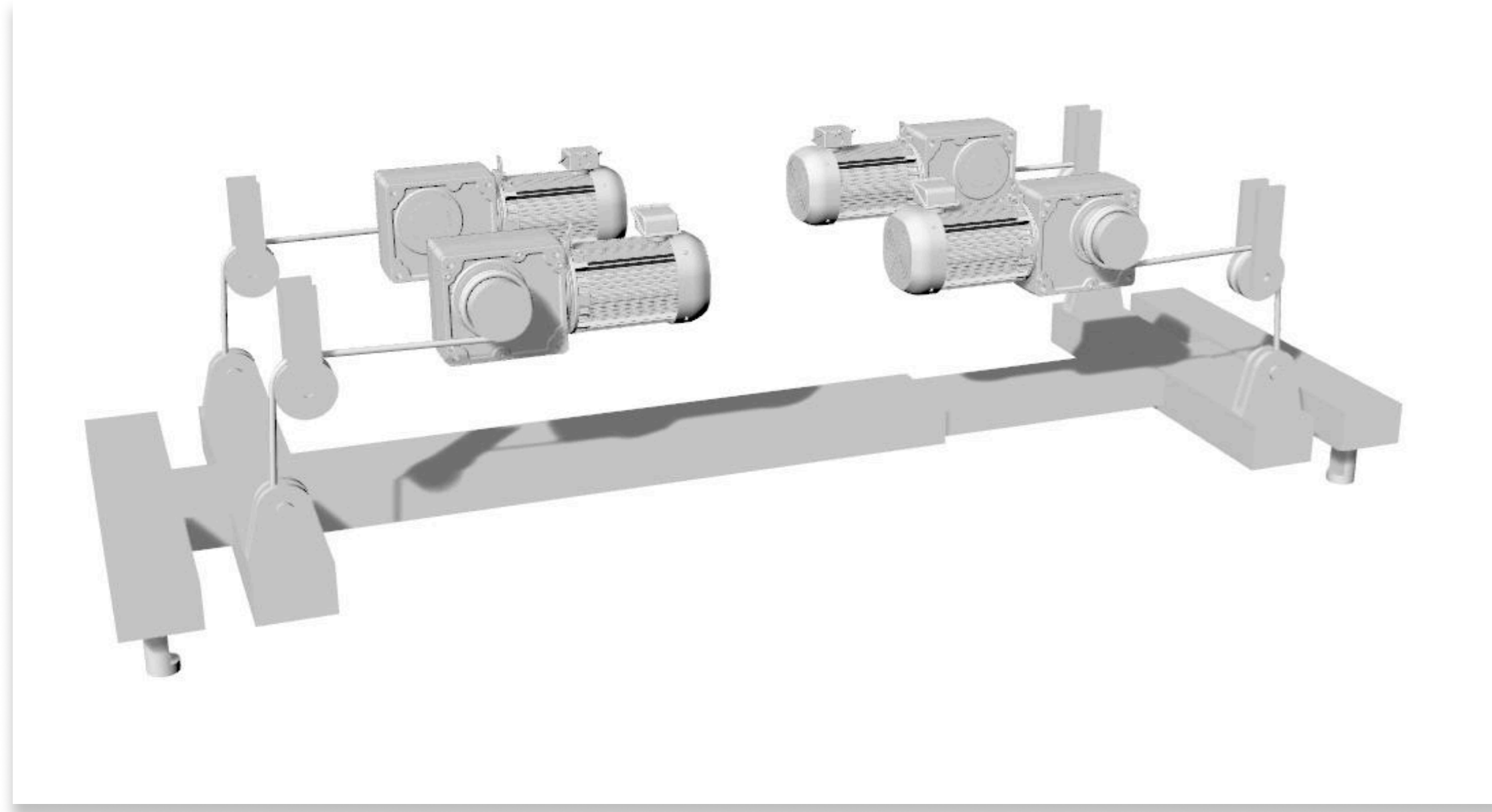
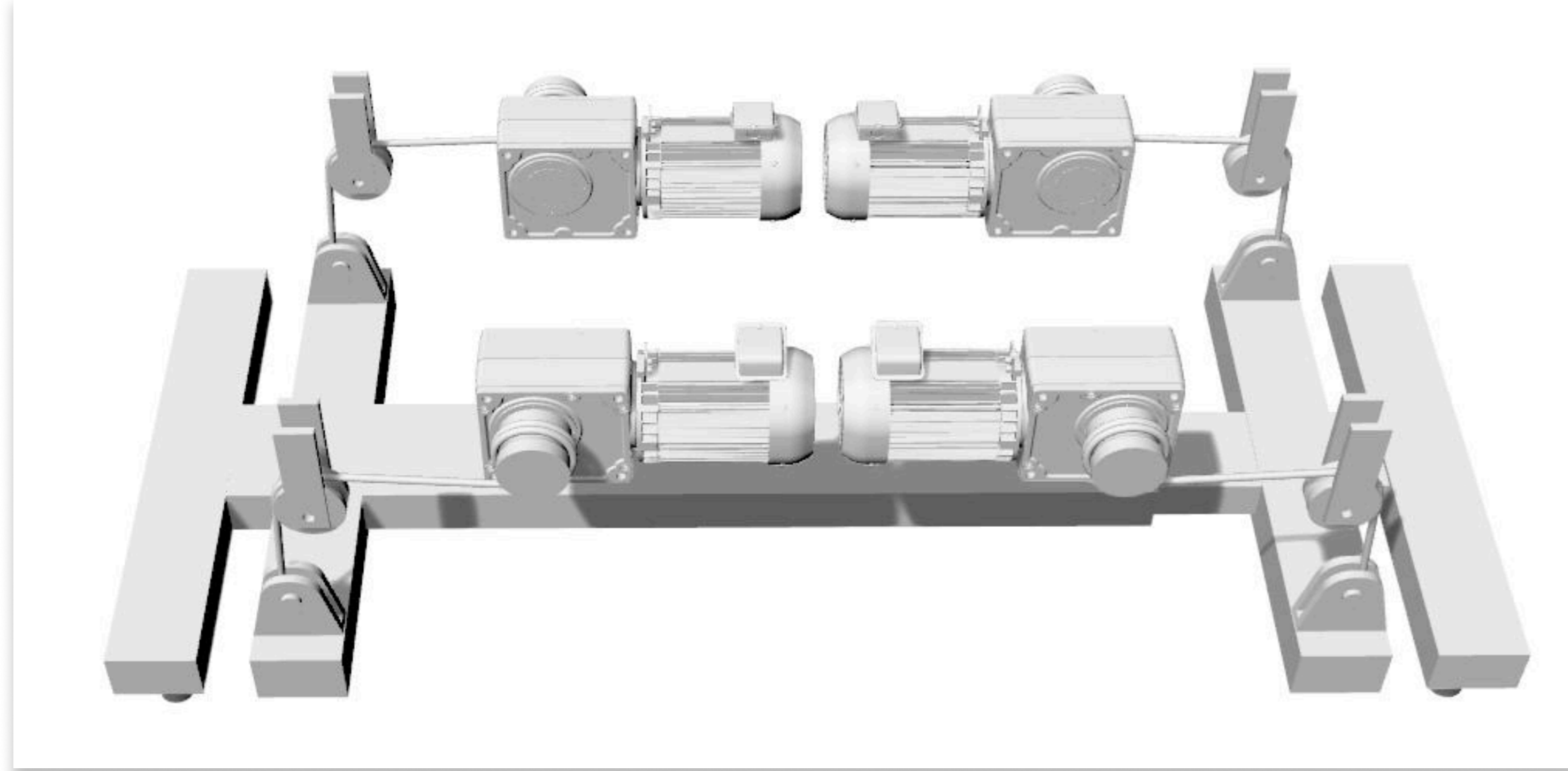

Expandable structure, can fit different sizes of storage boxes, for different organs as a pavement in the future

Run the motor to lower the clips and open them until they line up with the holes in the box.

Place the clips into the box air

Then, retract the clip to secure the box and activate the motor to raise the organ storage unit into the drone.

Prepare for flight.

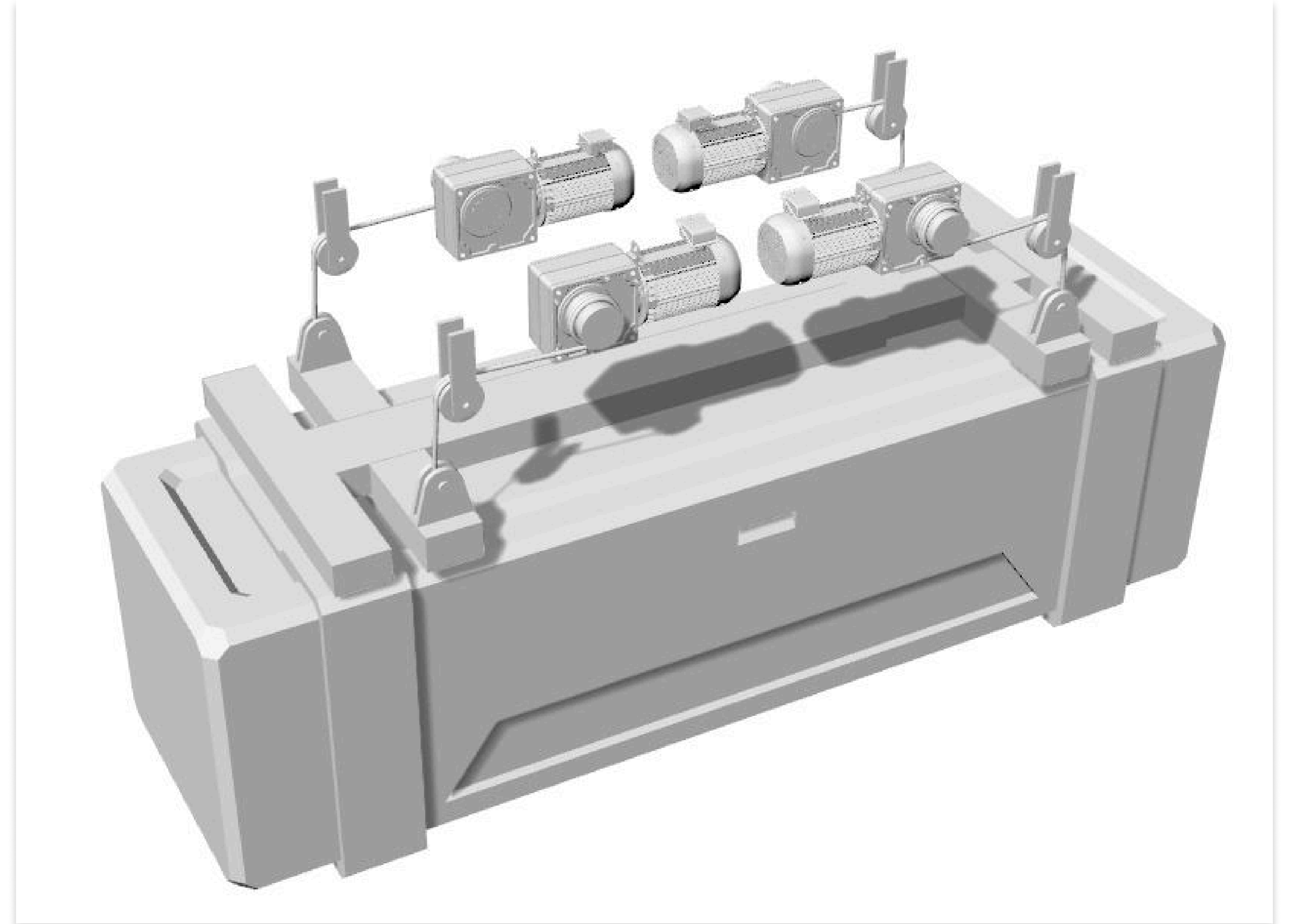

Detailed Drawing-CAD



Sonar

Real-time monitoring of surrounding buildings and various obstacles to minimise the likelihood of accidents

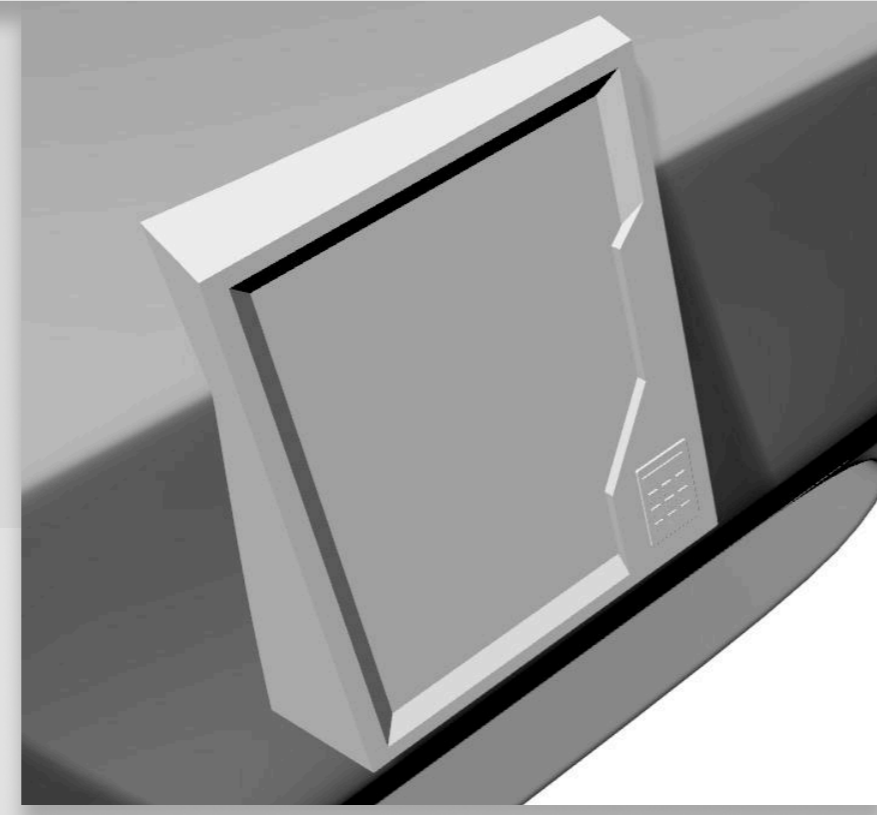

palmprint ID

Avoid organs being taken by bad guys and ensure successful delivery of organs to hospitals

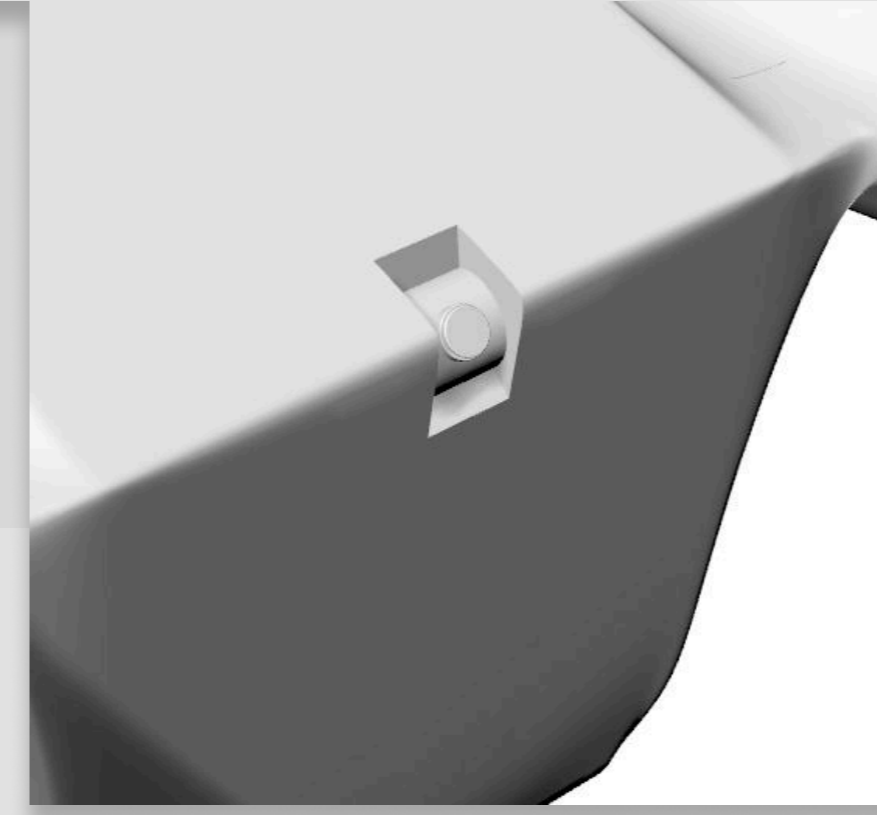

Camera 1

Captures and uploads live footage of the front

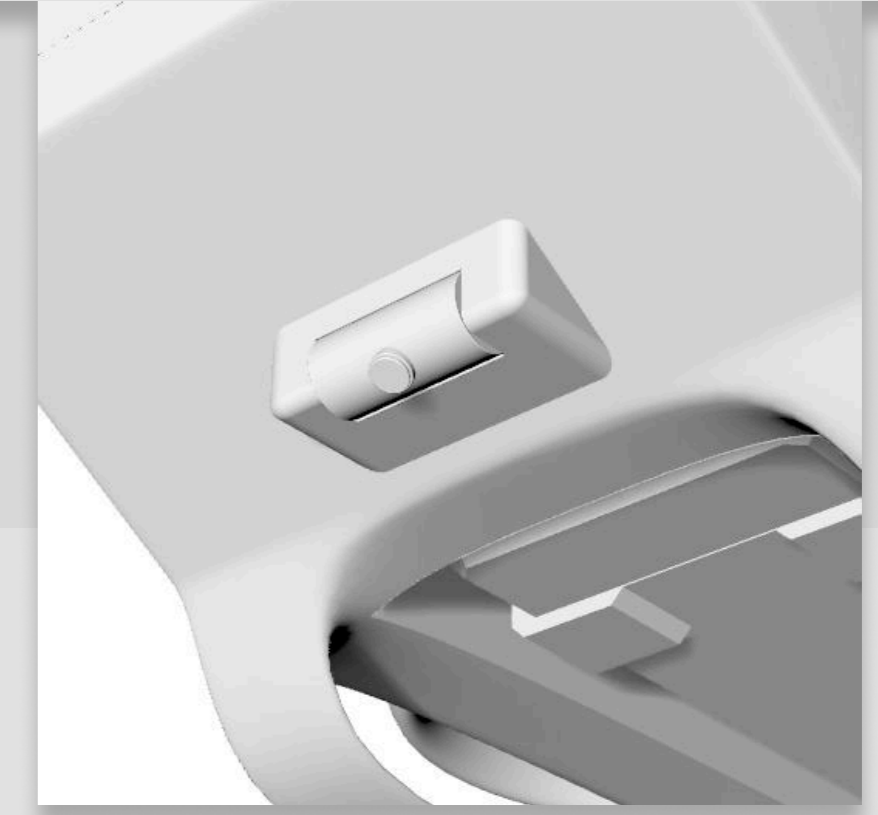

Camera 2

Capture and upload real-time footage of the underside, so you can have a video to fall back on in case of an accident.



Rotor Cover

Prevents the rotor from being affected by other things during operation leading to damage

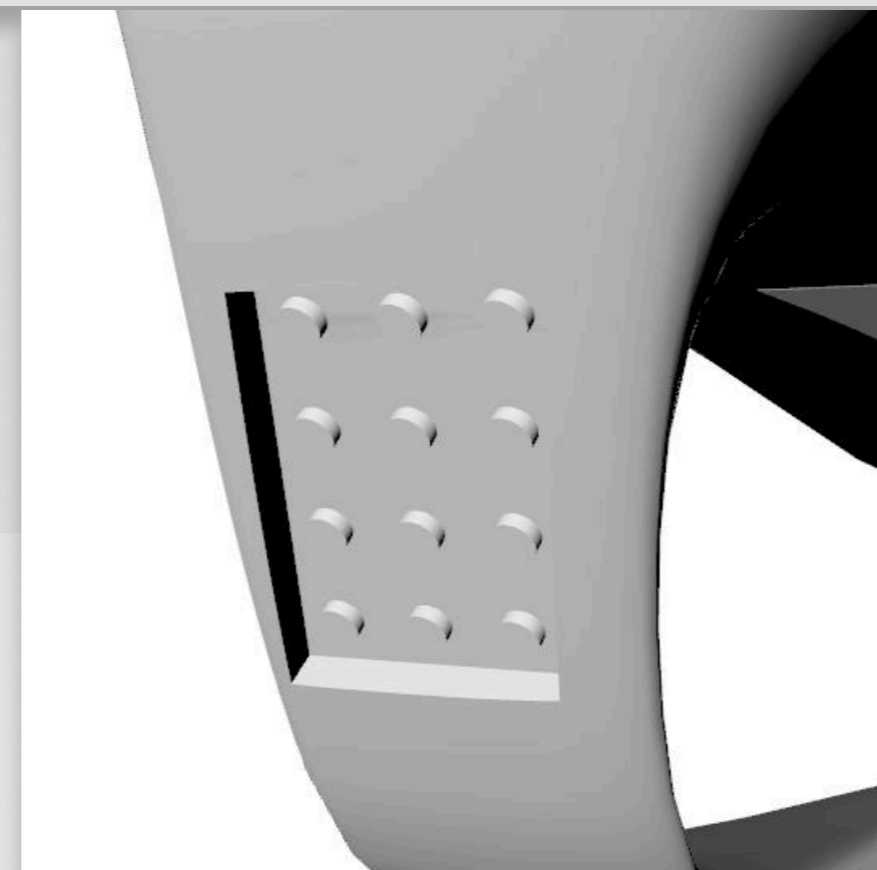

Footrest Light

Flashing red light in dark conditions to send a message to others that there is a flying object here.

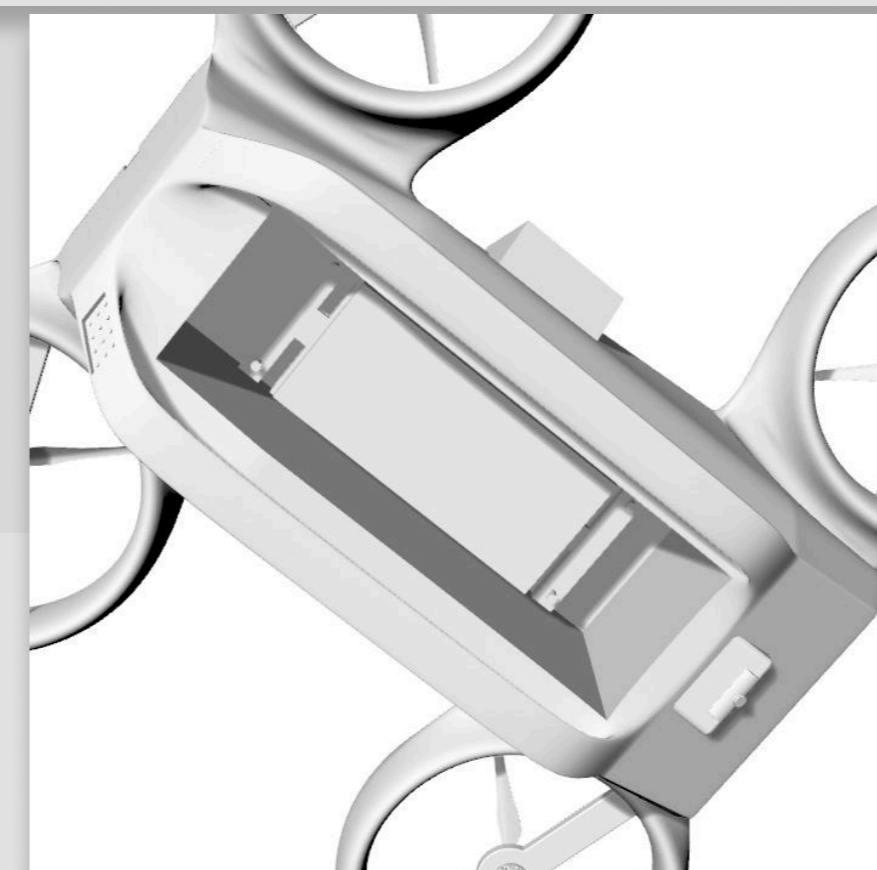

Cargo Bay

I built it big enough for all kinds of deliveries.



Overall Shape

The overall streamlined structure ensures sufficient transport space while minimising wind resistance.

CAD Final

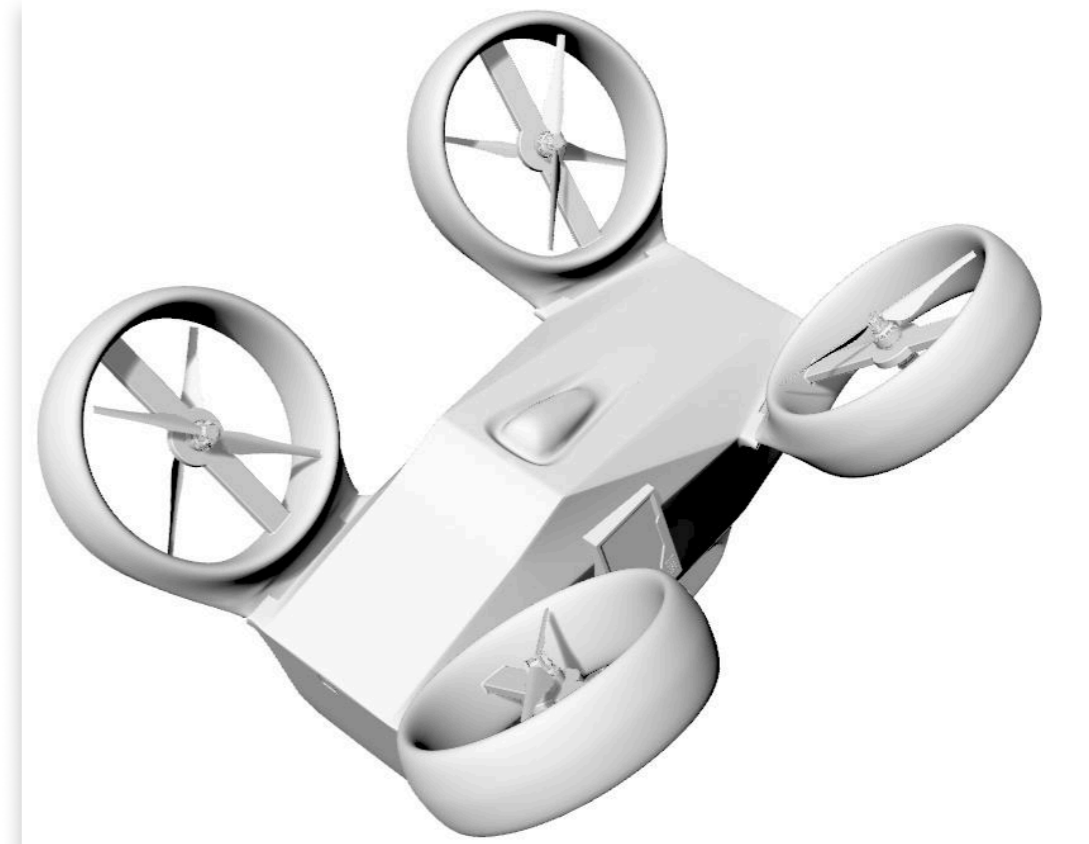
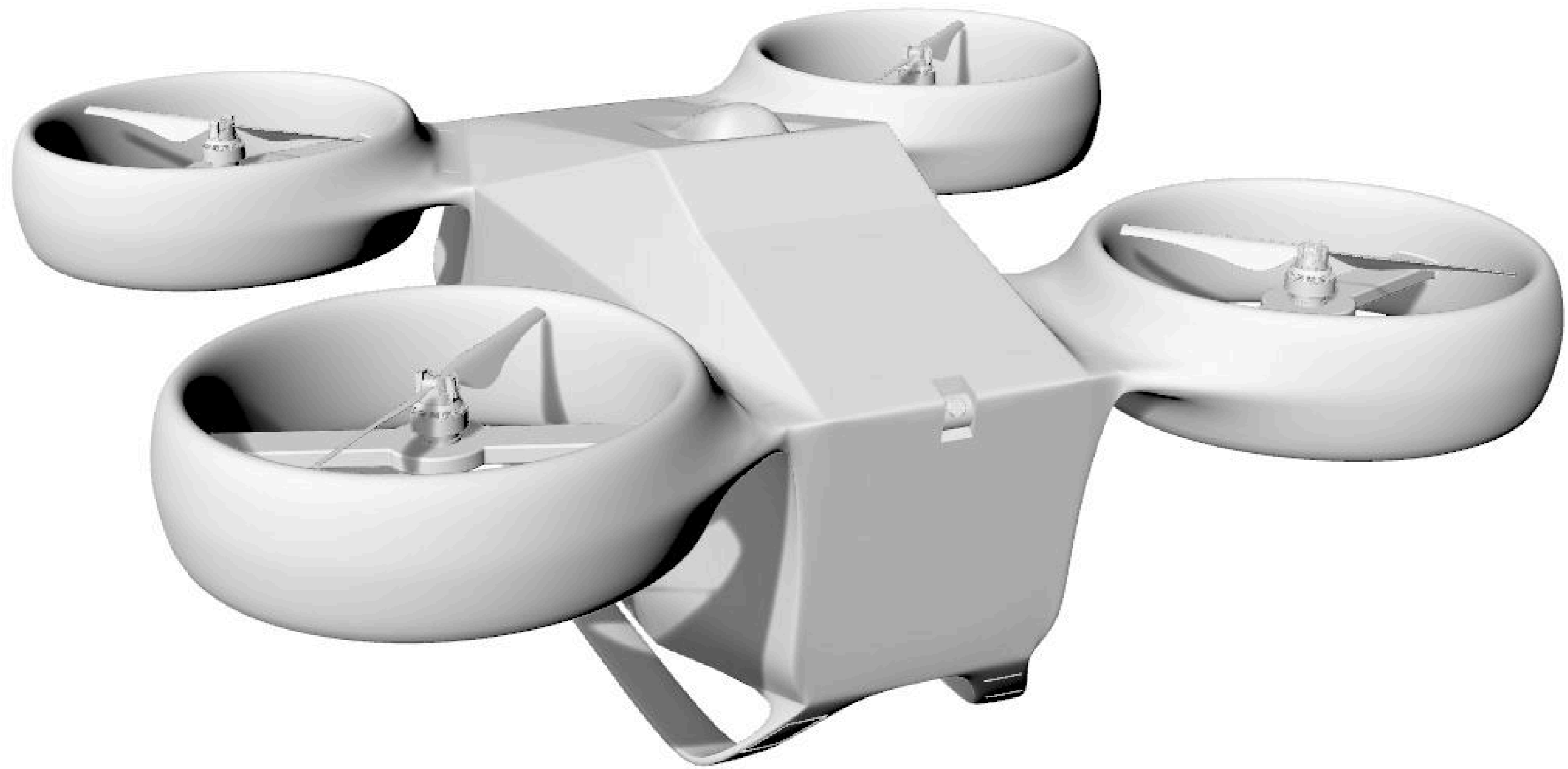

3D Printing Process

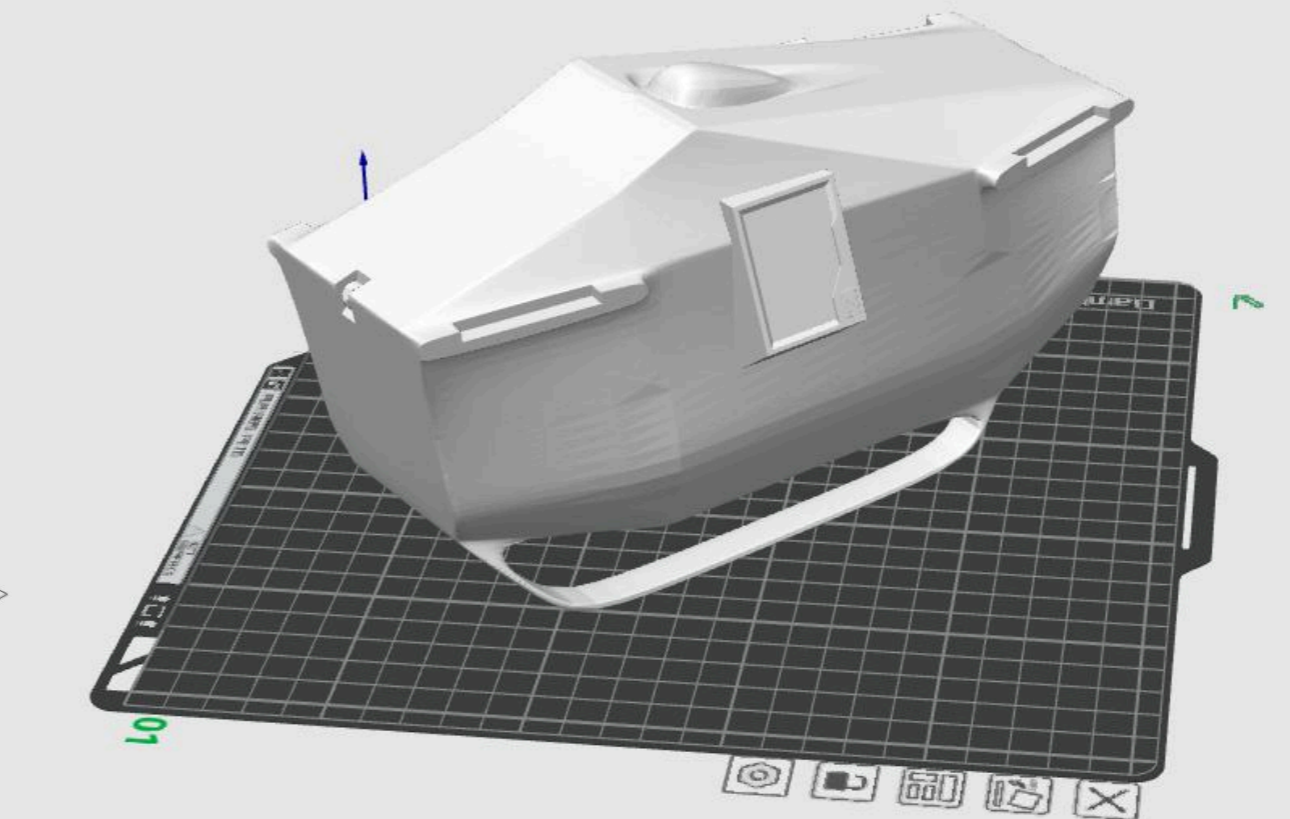
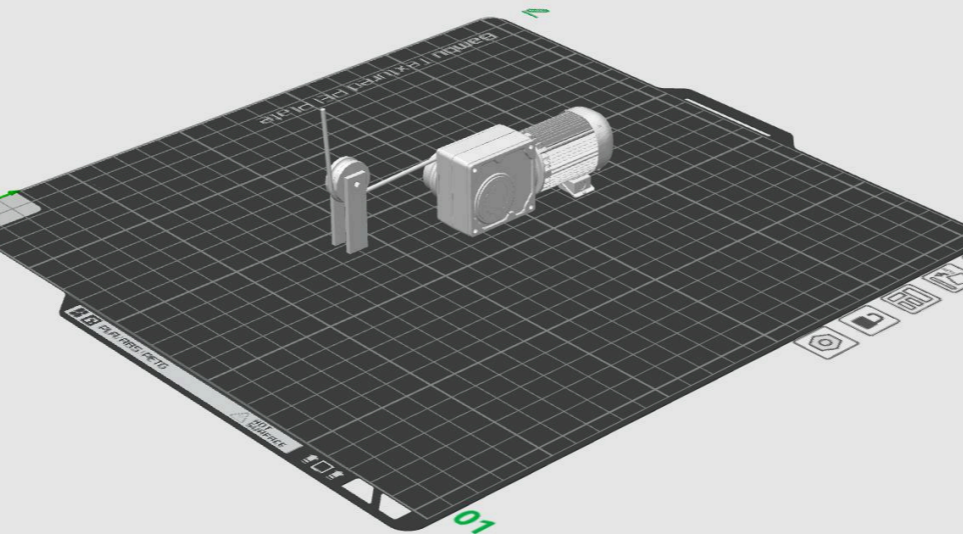
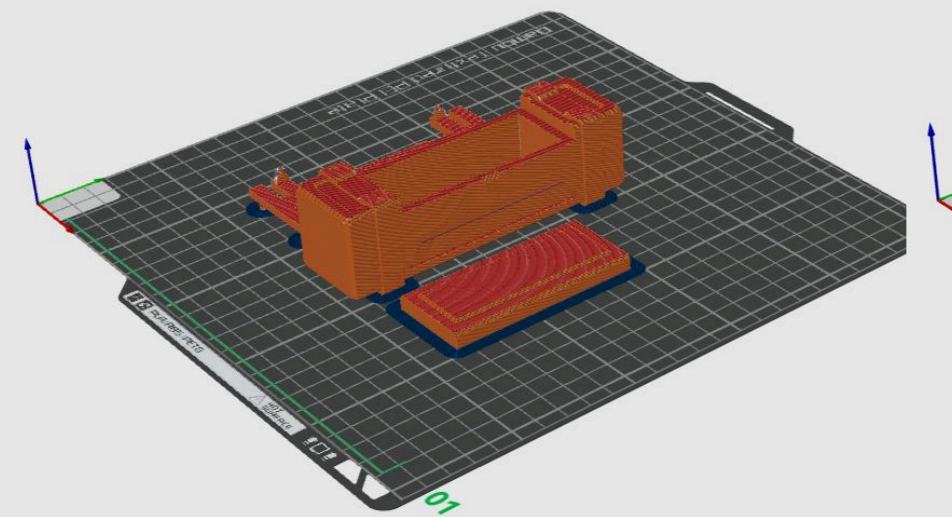
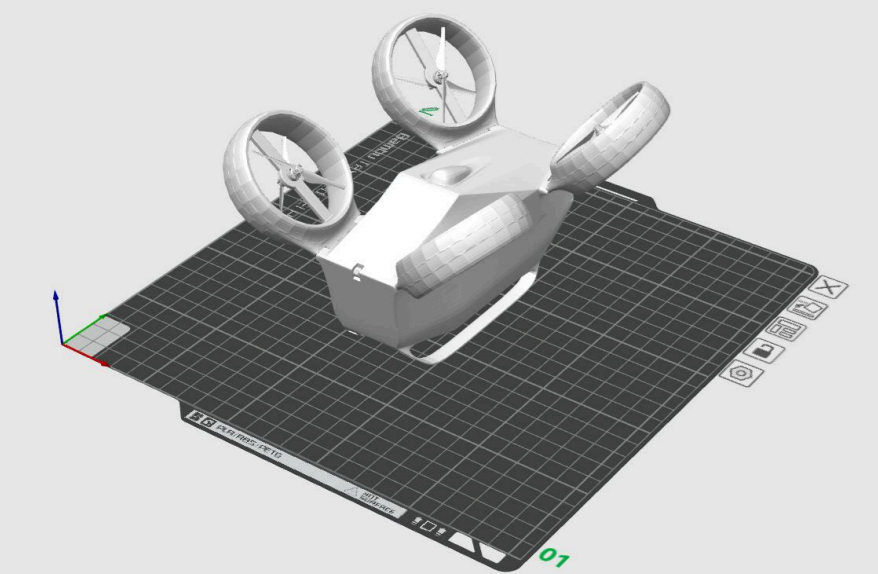
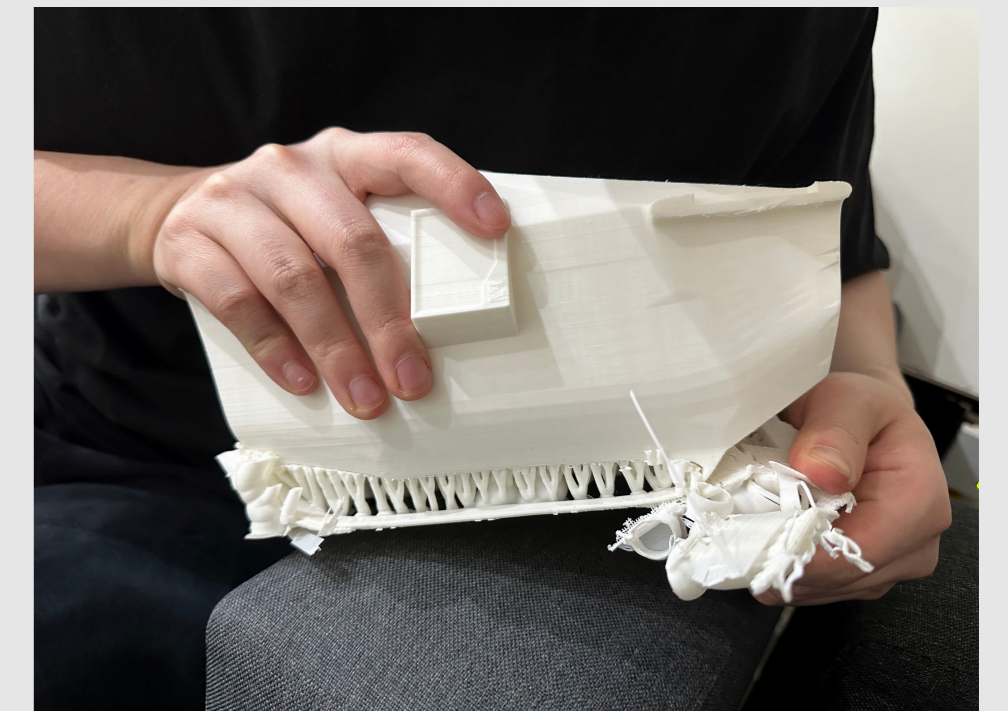
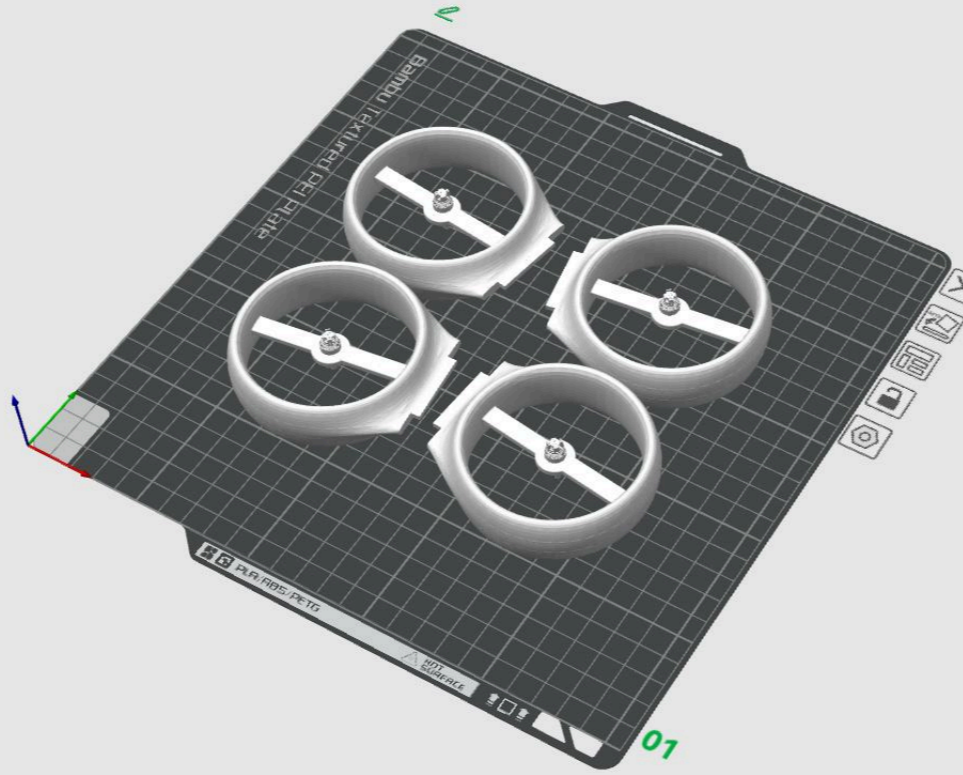

3D Printing Final

Isometric scaling of the final version of the drone

Enlarged organ storage containers

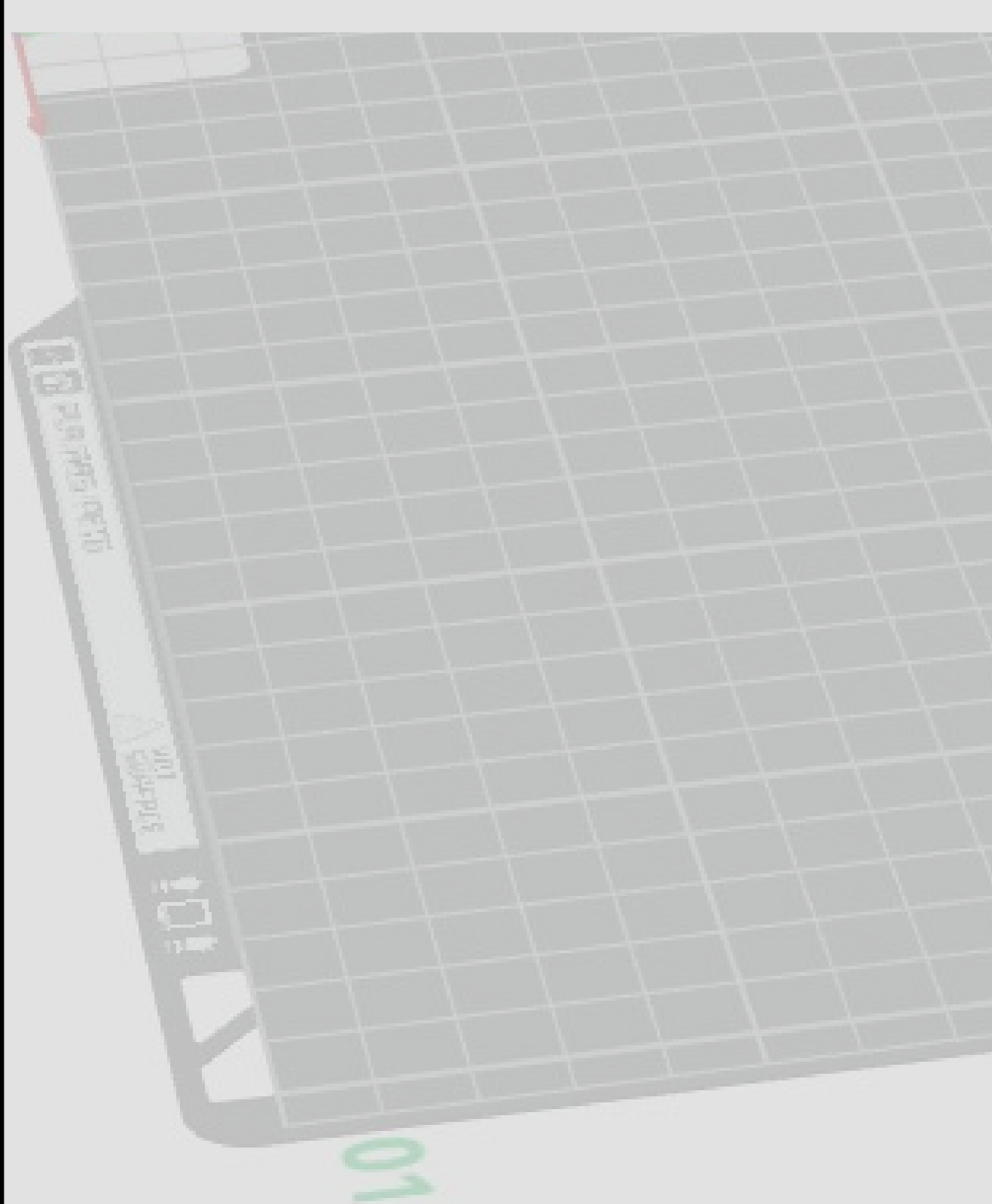

The Chosen Colour

UK Emergency Colours

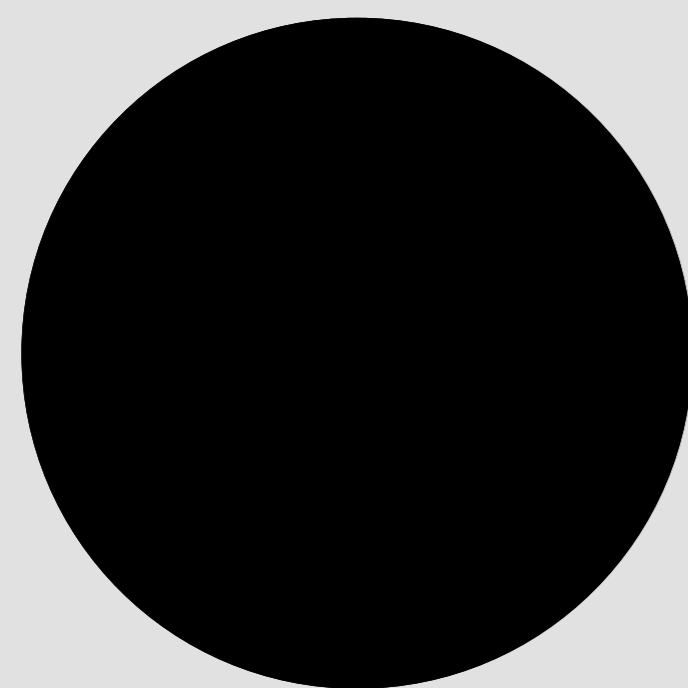

Bomb Threat

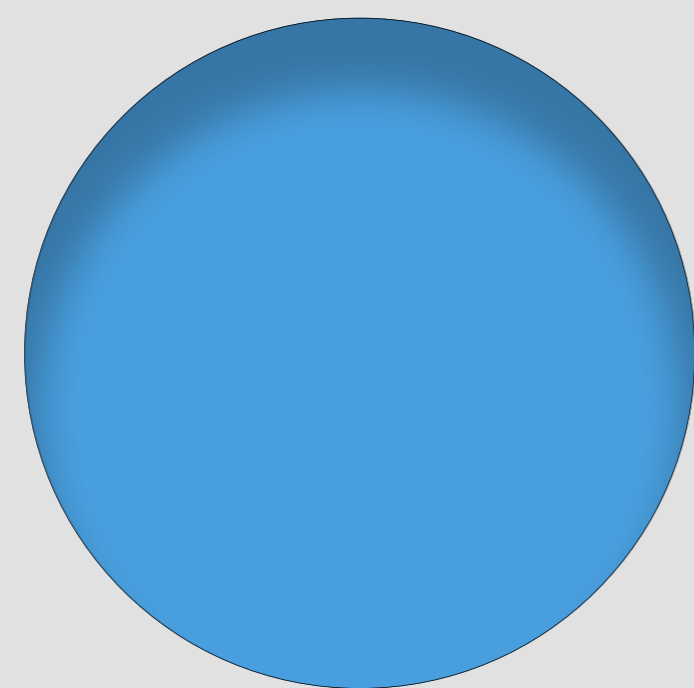

Cardiac Arrest

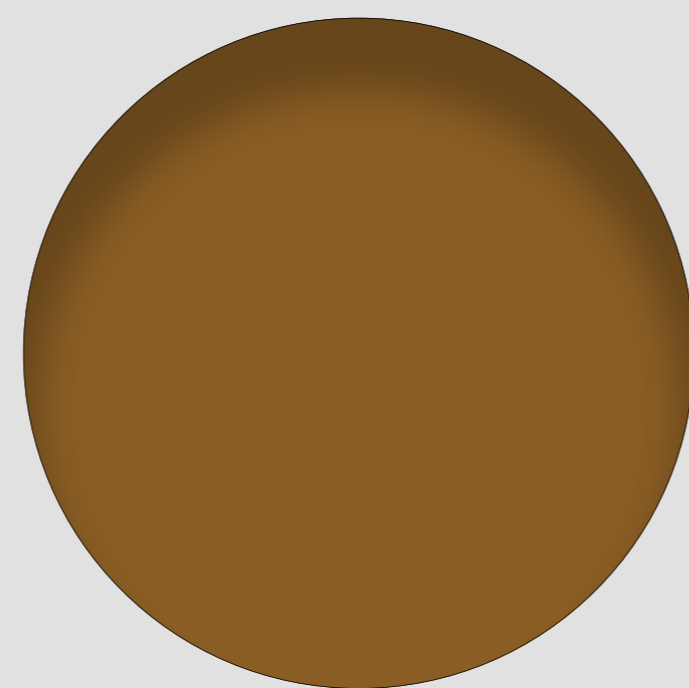

Chemical Spill

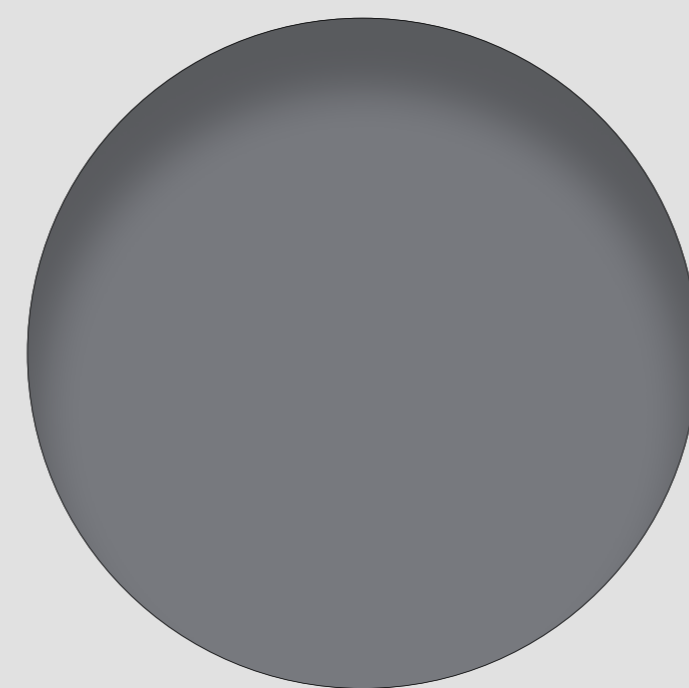

Air Exclusion

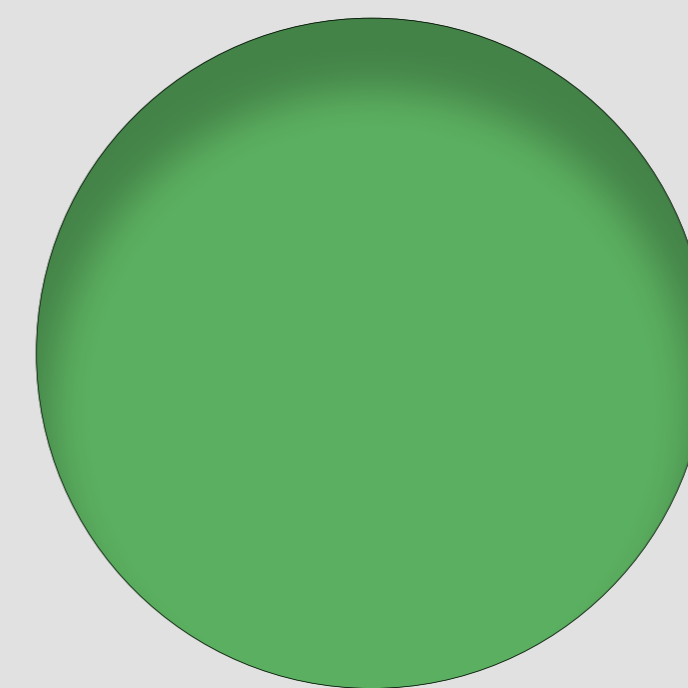

Evacuation

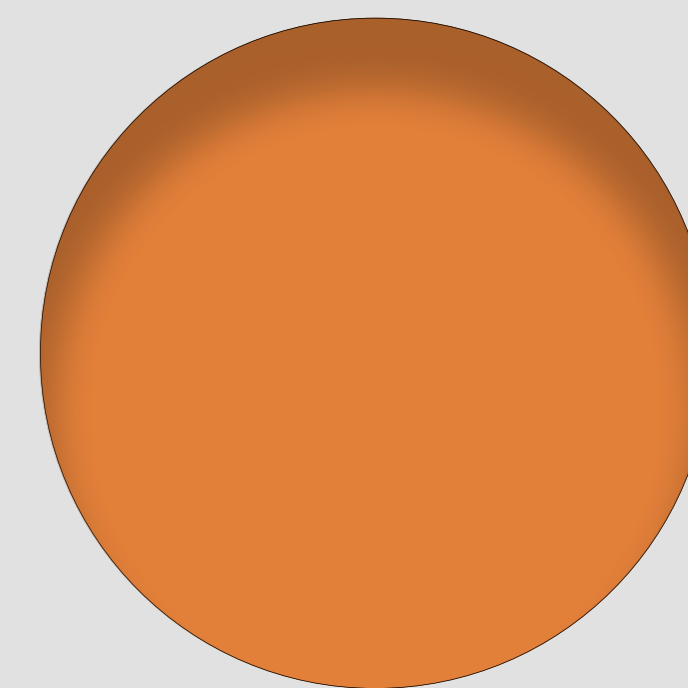

Mass Casualty Accident

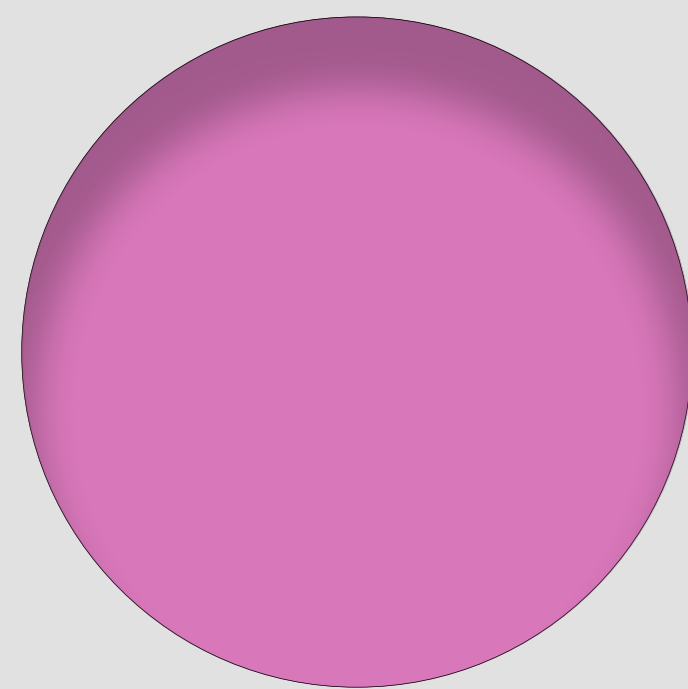

Pediatric Emergency

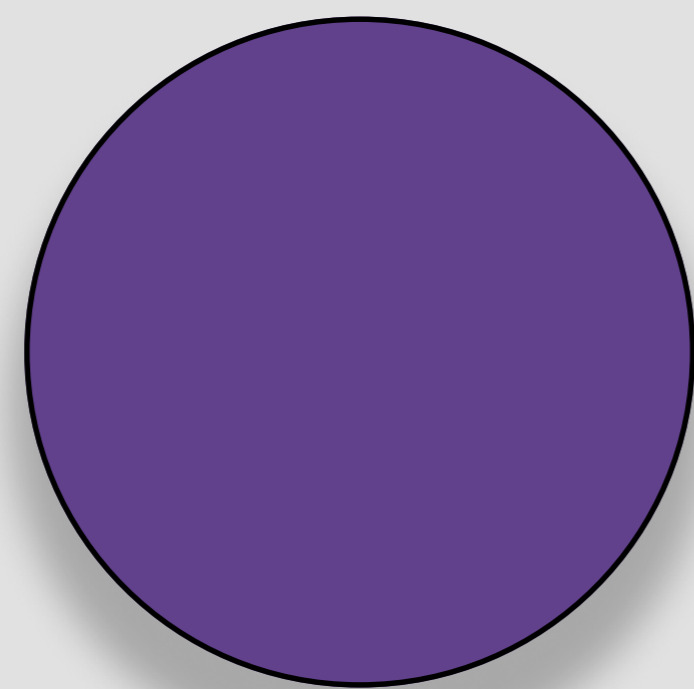

Medical Emergency

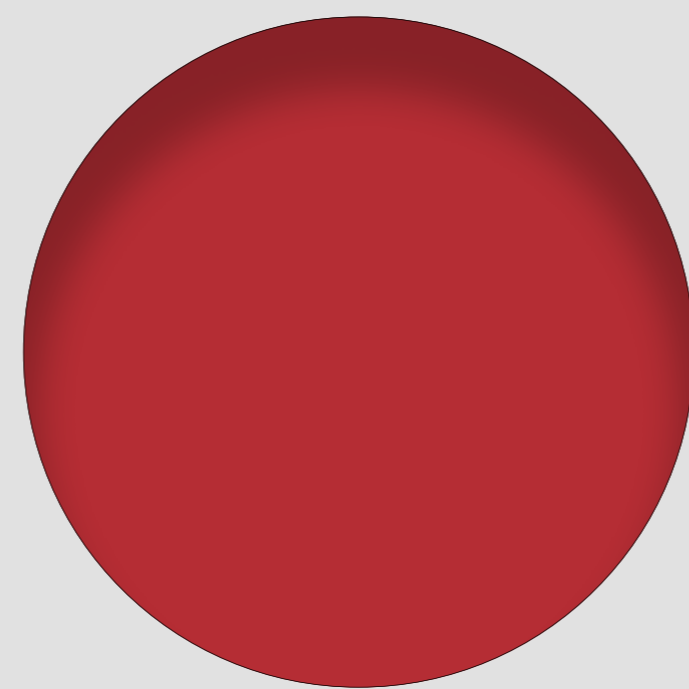

Fire

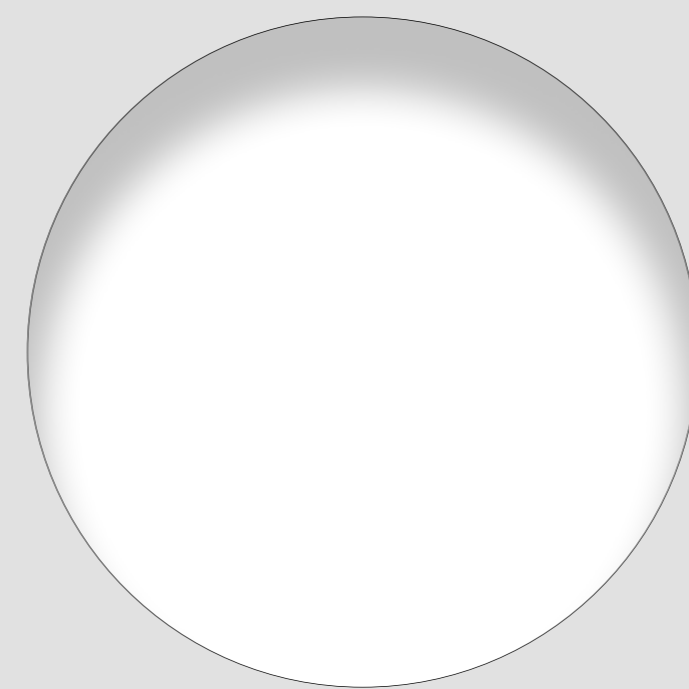

Violence

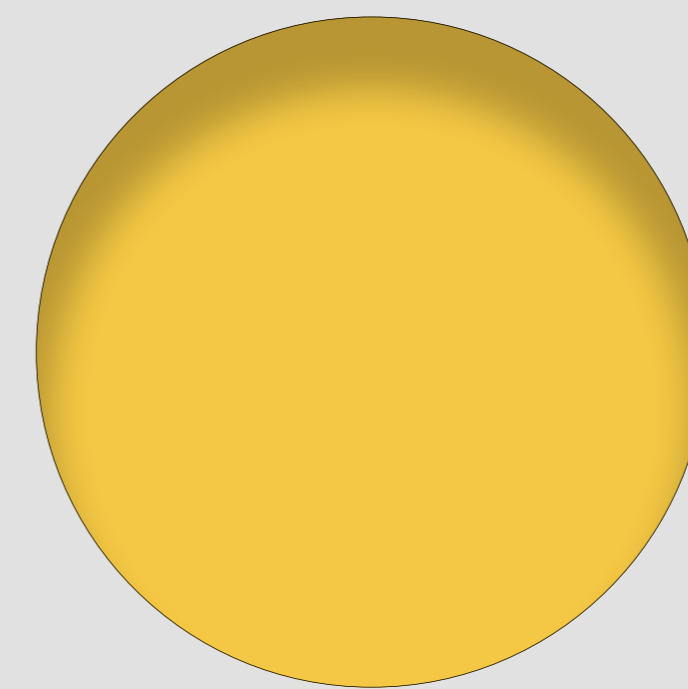

Missing Patient

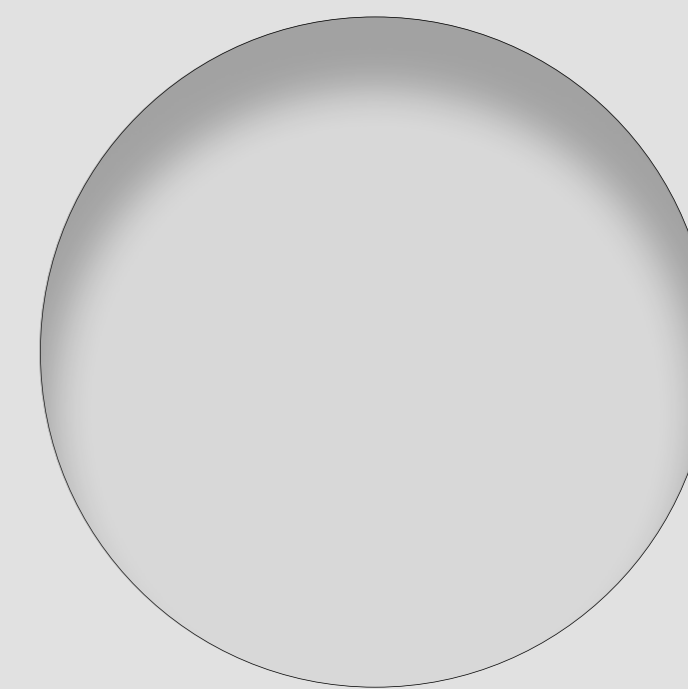

Bomb Threat

Fuselage construction materials (lightweight & high strength)

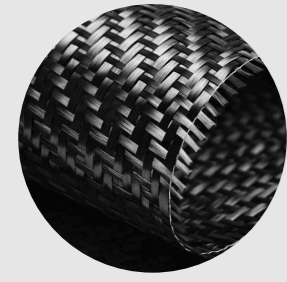

Carbon Fiber Composites

Ultra-lightweight, high-strength, corrosion-resistant, reduced energy consumption, enhanced structural stability.
UAV frames, wings, housings.

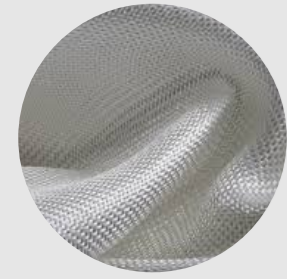

Fiberglass Composites

Lower cost, good impact resistance and rigidity, but slightly heavier than carbon fibre.
Fuselage shells, supports.

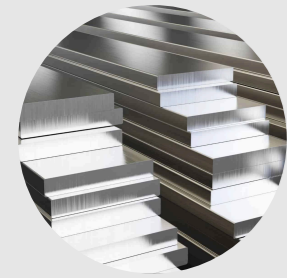

Aluminum Alloy

Lightweight, high strength, corrosion resistant, suitable for load-bearing structures.
UAV frame, support structure, enhance the rigidity and durability of the fuselage.



Titanium Alloy

Stronger than aluminium, corrosion-resistant, high temperature-resistant, suitable for high-end UAVs.
High load bearing parts, such as key connectors and brackets.

Materials for Electronics and Sensing Systems

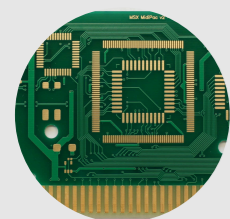

Copper & Gold (Circuit Board Materials)

Drone circuit boards (PCBs), signal transmission, connectors to ensure stable current transmission.



Silicon

Used in sensors, control chips (MCU/AI chips), processors and integrated circuits.



Polymer & Glass (Optical Systems)

Cameras, optical sensors, laser radar (LiDAR) and other UAV vision systems.



Polymer Plastics (ABS/PC/PEEK)

UAV housings, fixing components, providing heat and impact resistance and reducing weight.

Powertrain Materials (Batteries & Motors)



Lithium-ion batteries (Li-ion) / Lithium polymer batteries (LiPo)

Provide power for drones with high energy density and lightweight characteristics.



Rare earth materials (NdFeB)

Brushless motor (BLDC) for UAVs, improving power output and reducing energy consumption.

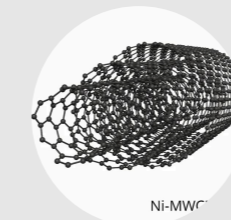

Nickel Alloy & Carbon Nanotubes (Conductive Materials)

Enhance motor performance and improve power transmission efficiency.

Joints and structural reinforcements

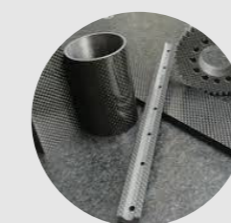

Carbon Fibre Reinforced Polymer (CFRP)

Used in UAV connecting structures such as brackets and paddles to improve durability.



Rubber & Silicone (Shock Absorbing & Protective Materials)

Shock pads, landing gear cushioning, enhanced impact resistance and protection of electronic components.

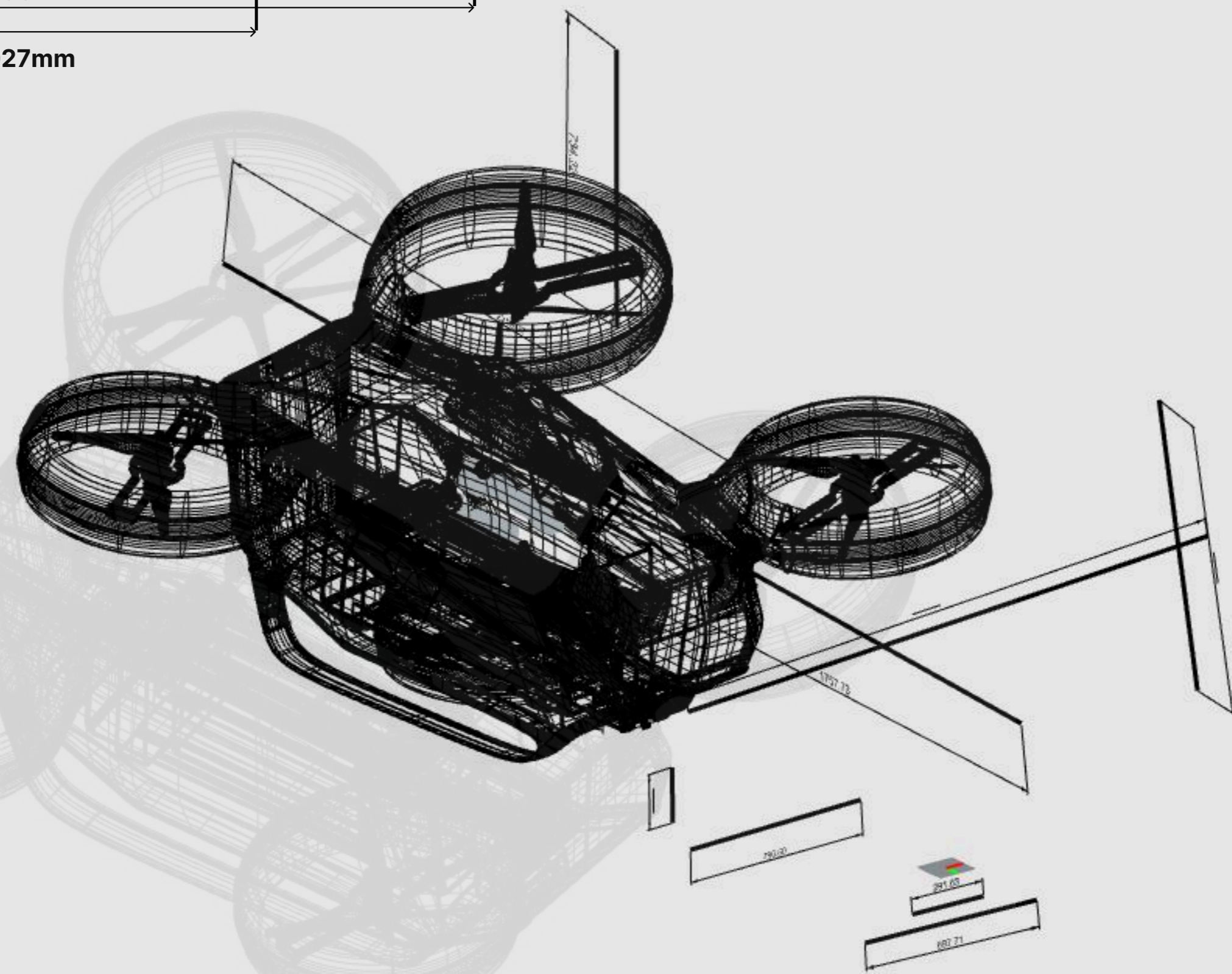
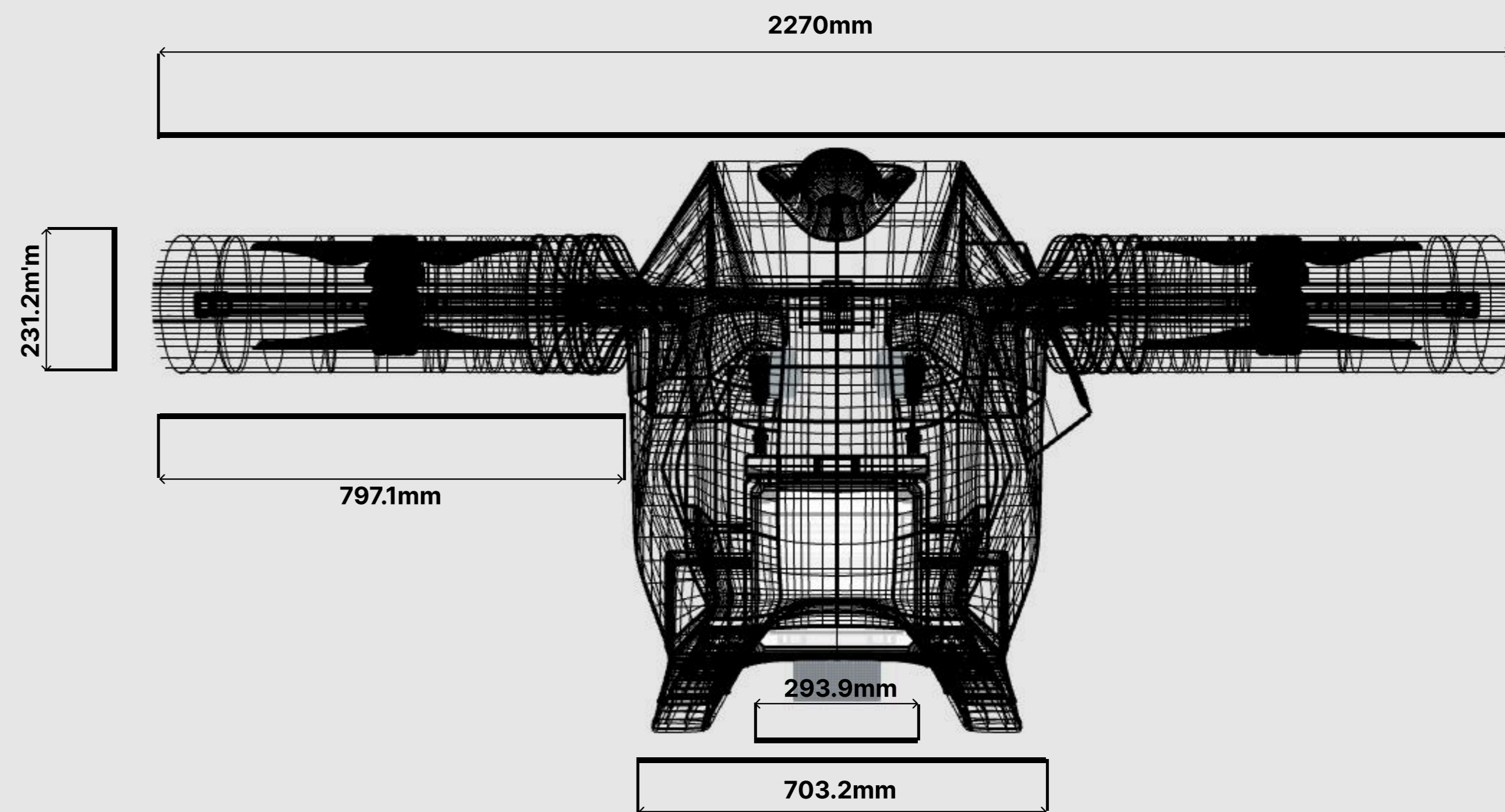
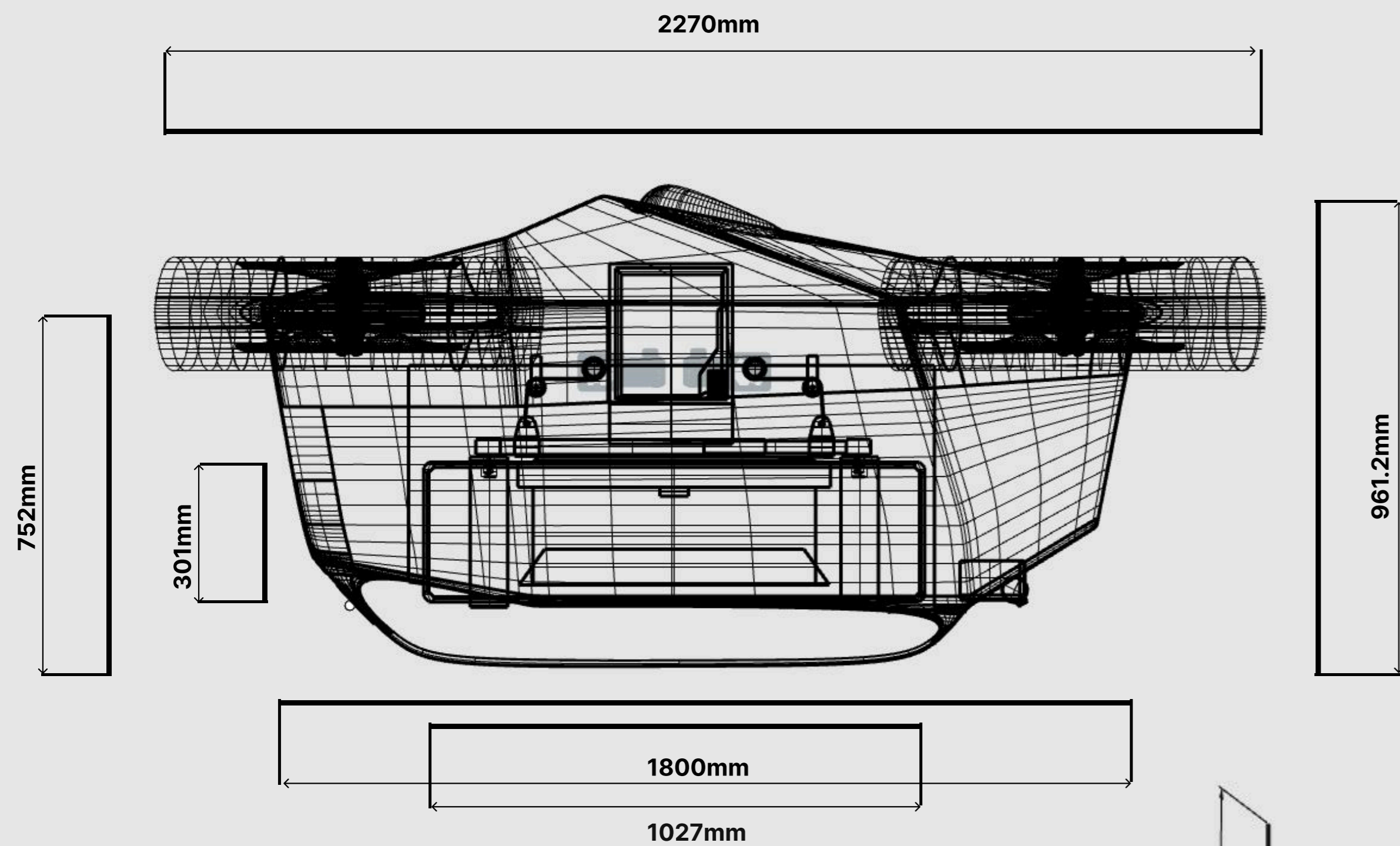

Length: 180 cm

Maximum Height: 96.12 cm

Minimum Height: 75.2 cm

Rotor Span (Unfolded): 227 cm

Function

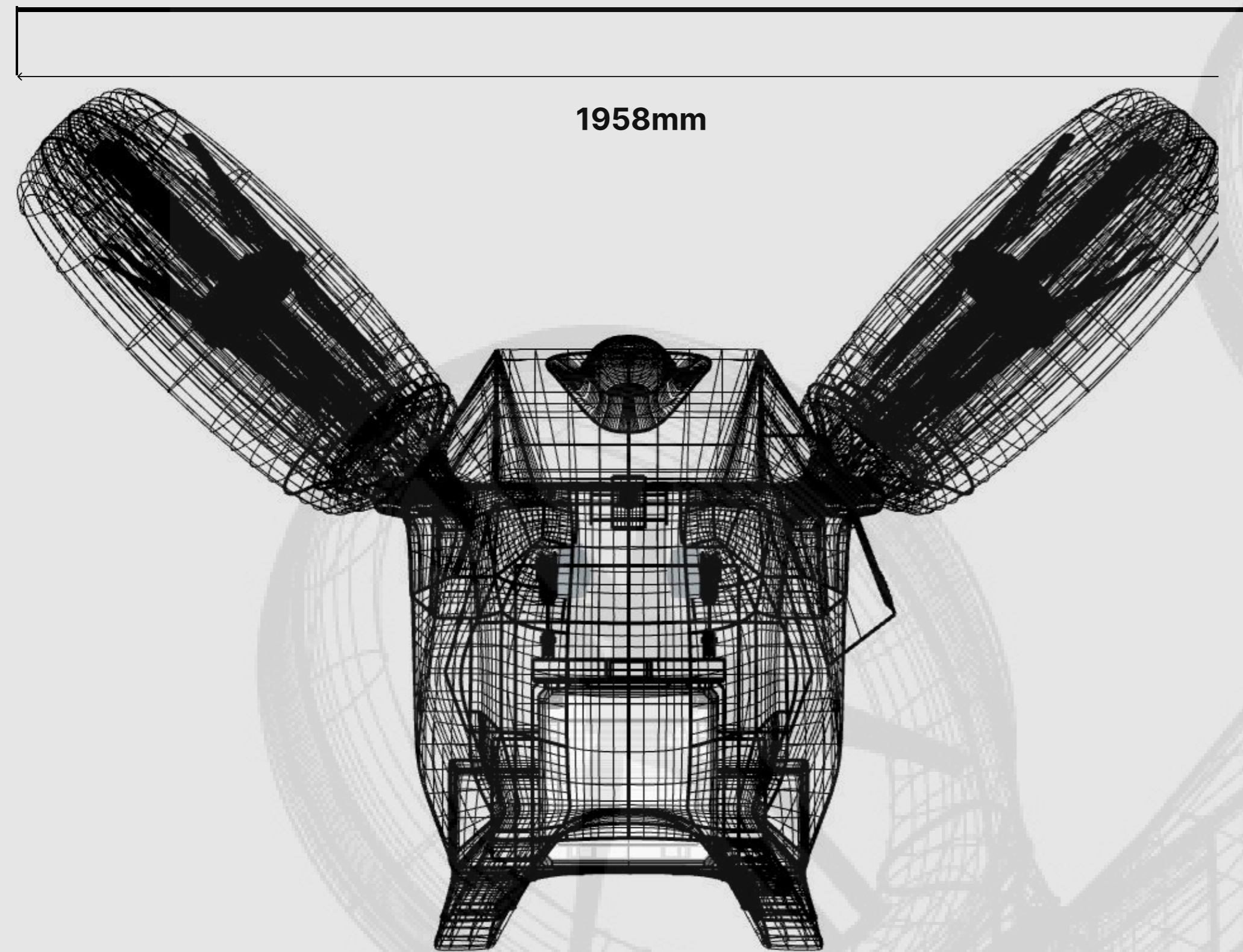

1958mm

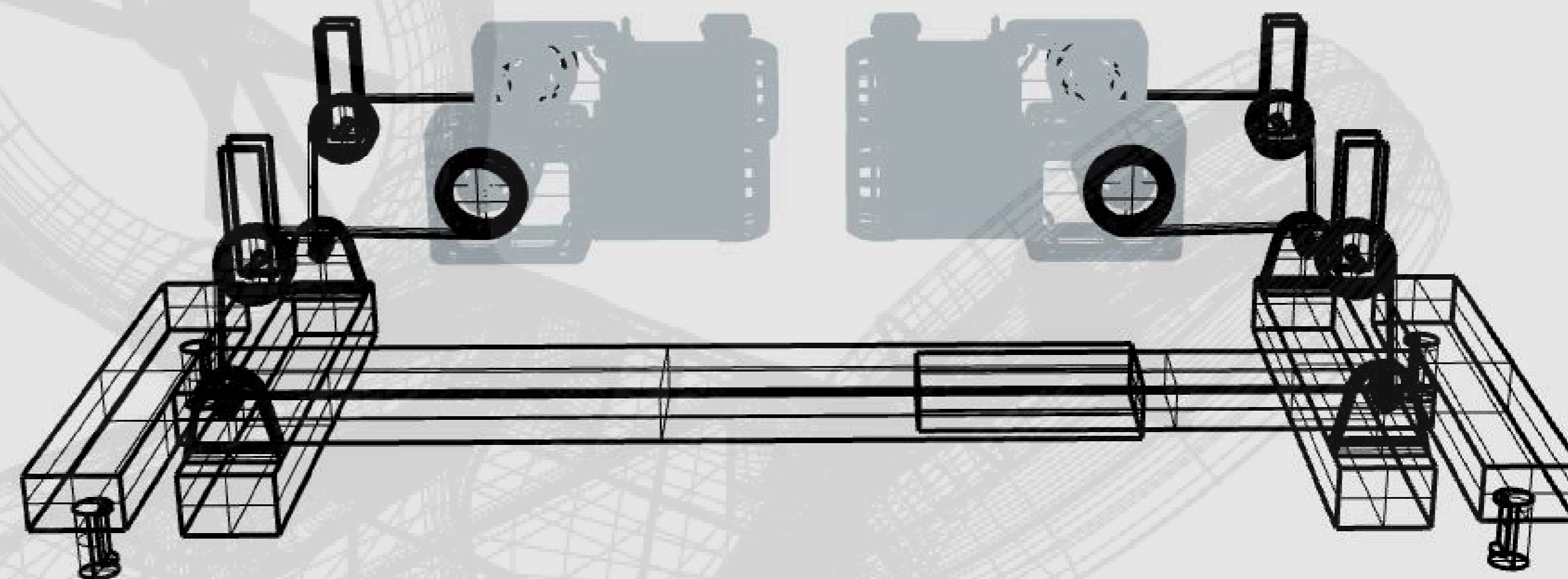

Rotor Span (folded): 195.8 cm

Organ Box Length: 102.7 cm

Box Height: 30.1 cm

Storage case dimensions based on portable medical renal dialysis machines

Portable dialysis machine (for home use):

Height: 30 - 60 cm

Width: 30 - 50 cm

Depth: 30 - 50 cm

Weight: 10 - 30 kg

301mm

306.9mm

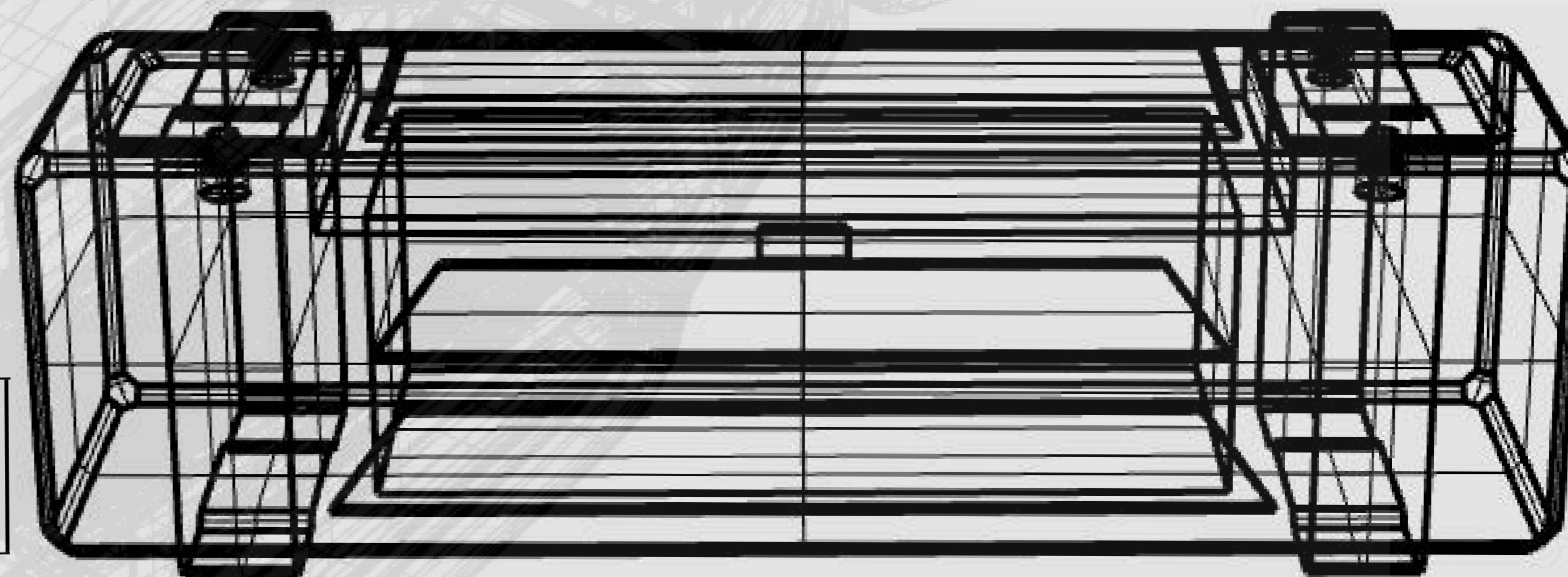

1027mm

Flight Version



Floor Standing Version



Organ Storage Box



Rising and lowering of the wire is controlled by a motor and pulley structure.

Clip it down and hold it in place.

Palm and Combination Locks

I designed a motorised rope lowering system.
At the end of the rope is a clamp.

Once it's attached to the storage box, the motor activates to tighten the rope and securely attach the box to the drone.

Rendering Detail

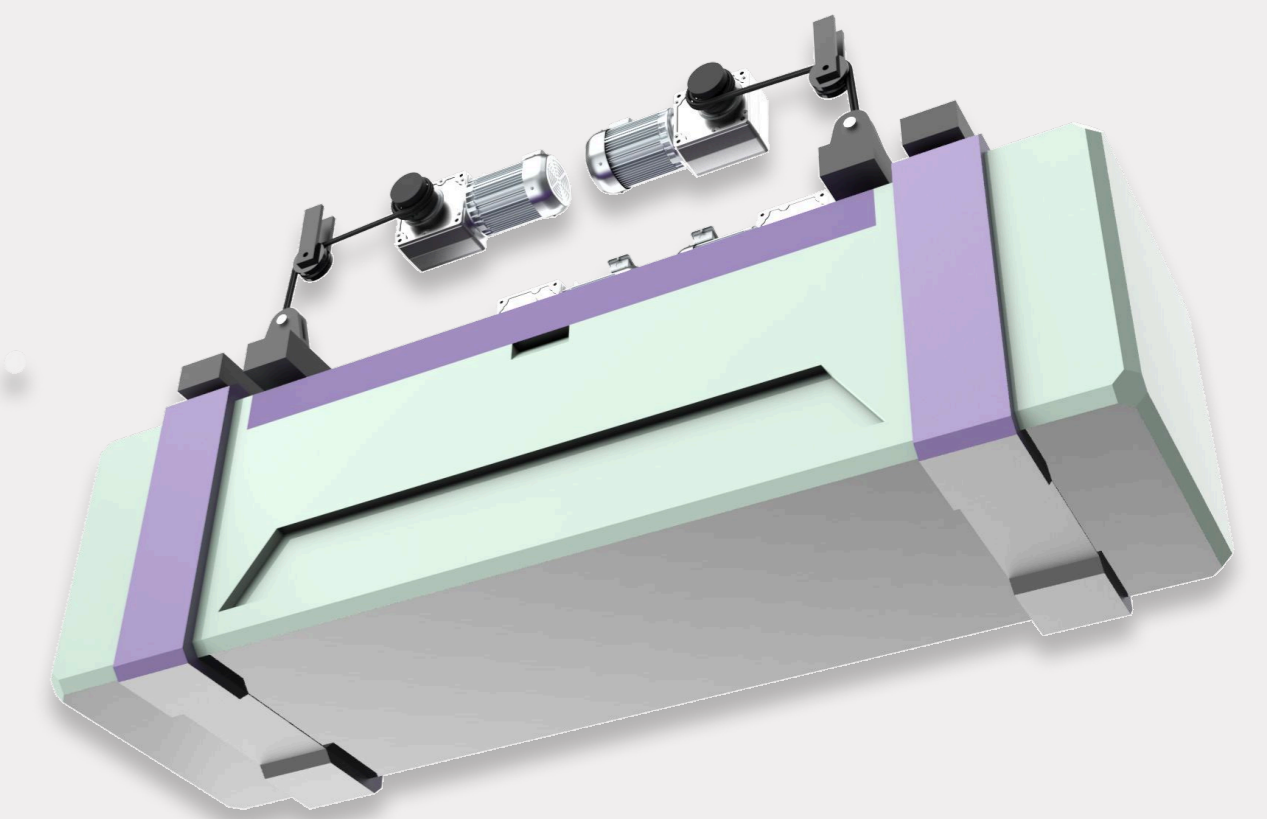
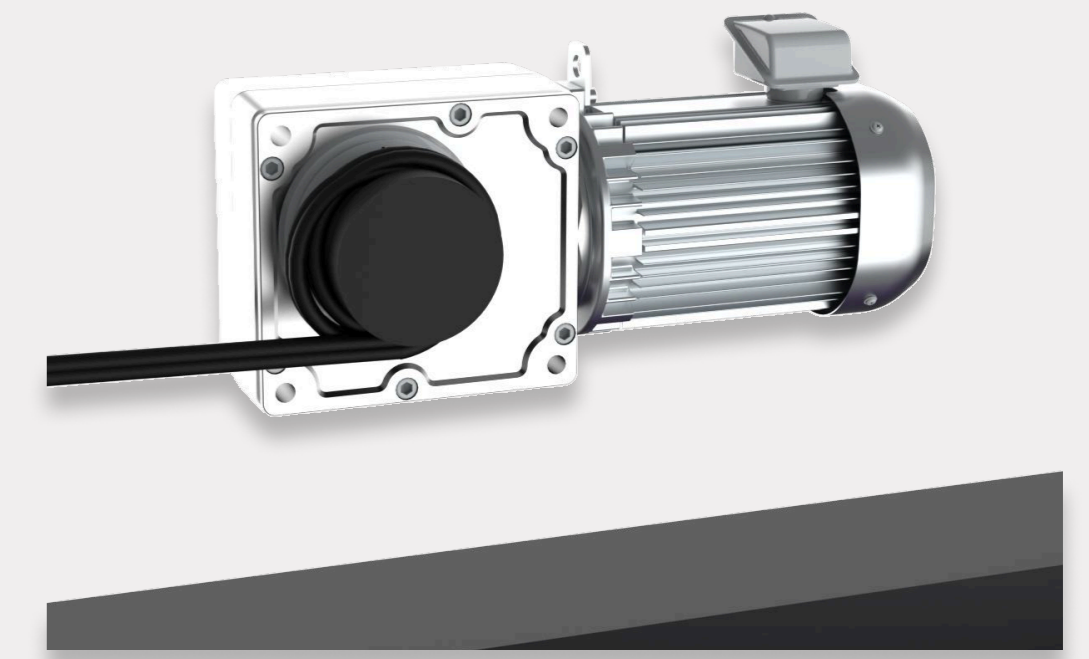
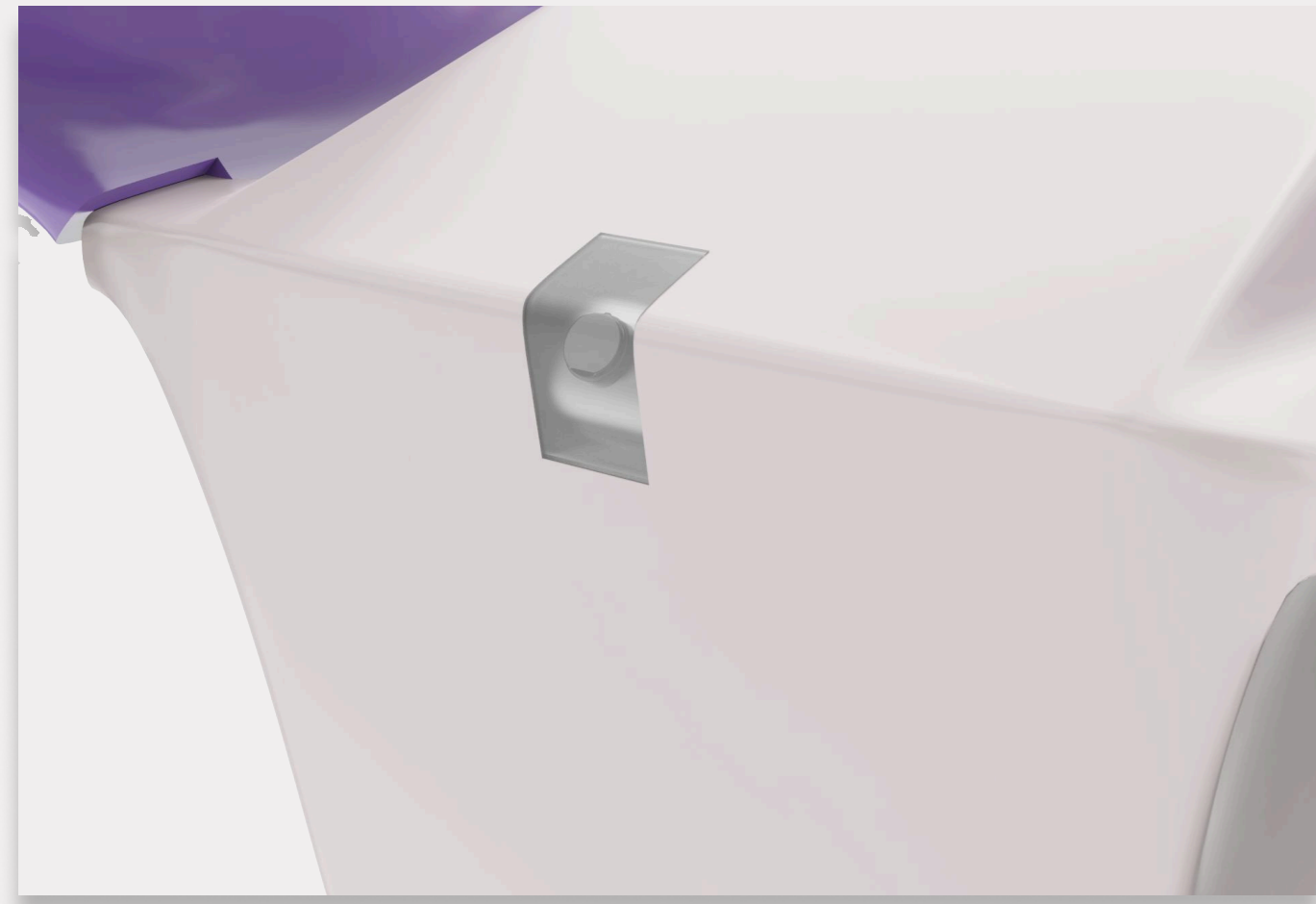

Explorde View

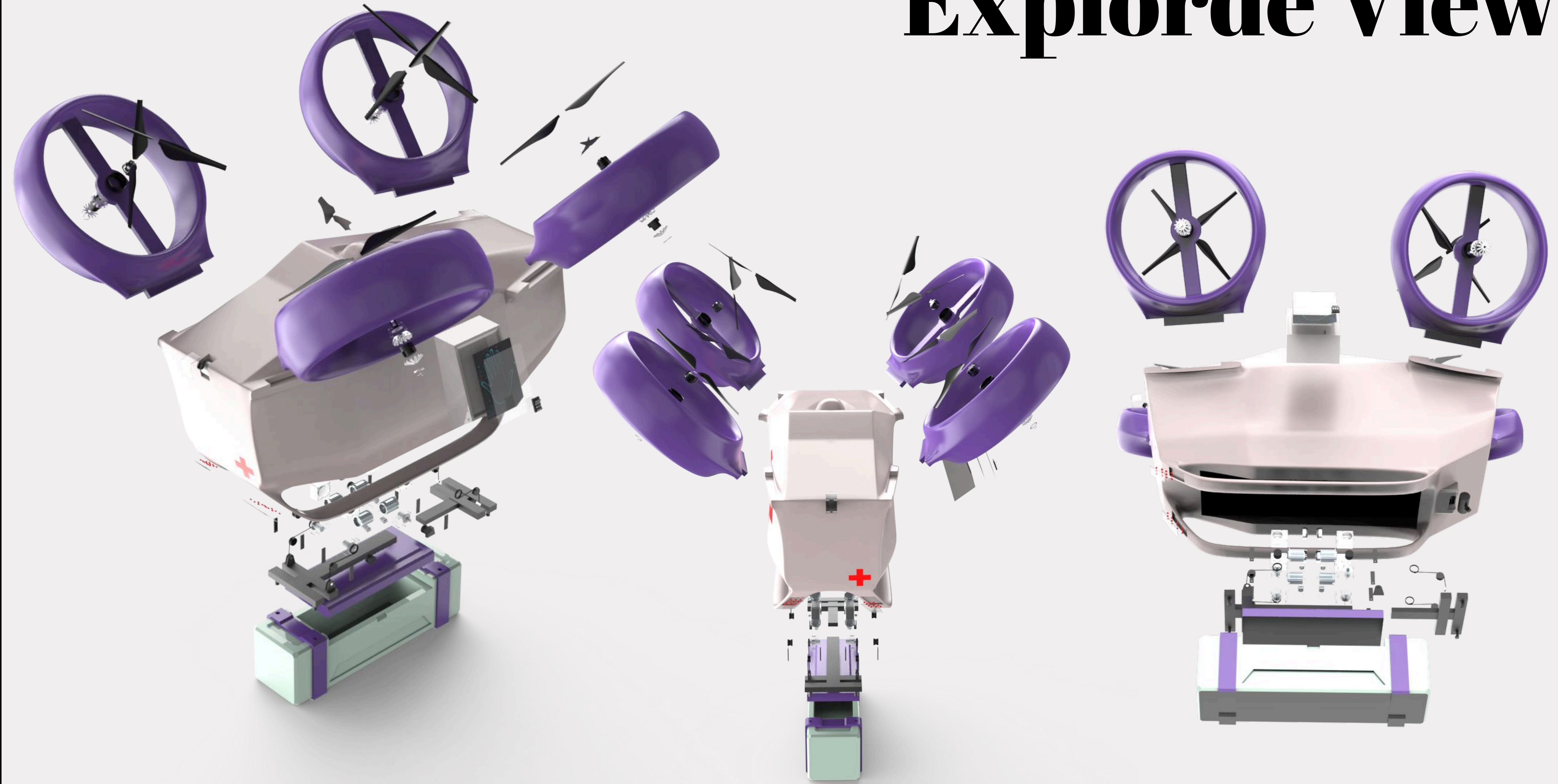

Scenarios



Story board

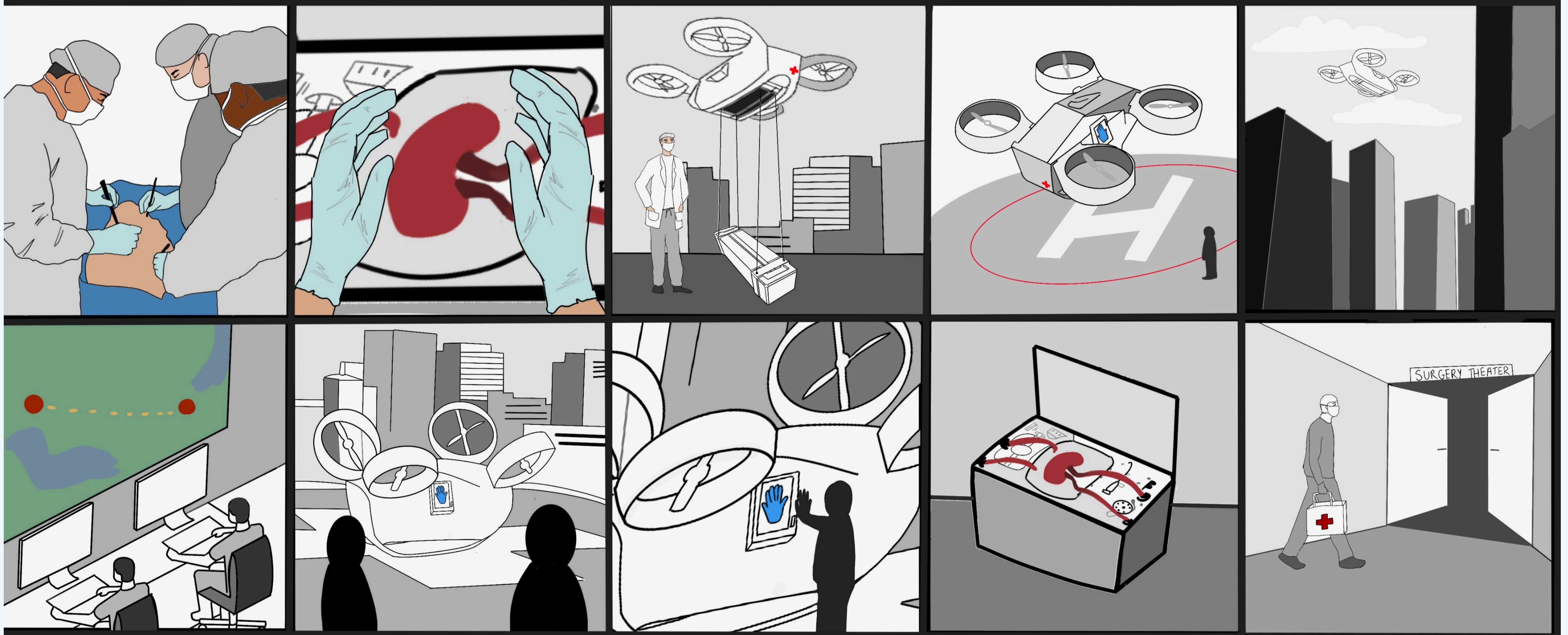

The integration of unmanned vehicles and automated tools into healthcare aims to improve efficiency, reliability, and response time, particularly in emergencies.

These technologies outperform traditional methods by analyzing and acting on data instantly, reducing dependency on human intervention and ensuring faster medical interventions.

While unmanned systems offer significant advantages, their widespread adoption faces challenges such as complex usability, limited functionality, and user trust issues.

A poor user experience creates resistance to adoption and raises social concerns about job displacement and adaptation difficulties.

To bridge the gap between cutting-edge automation and real-world usability, a human-centered design approach is essential.

Effective design should reduce complexity, improve adaptability, and ensure that users feel comfortable and secure rather than alienated.

This is especially crucial in healthcare, where trust in medical technologies directly affects their effectiveness.

Drones, for example, have the potential to revolutionize emergency medical response, delivering supplies or transporting patients quickly, especially in rural or disaster-stricken areas.

However, key design challenges include stability, ease of operation, and balancing automation with human interaction. Without addressing these factors, even the most advanced innovations risk being underutilized.

Unmanned technologies should enhance human well-being, not replace it.

By refining user experience, simplifying operations, and integrating intuitive interfaces, these systems can achieve greater adoption and effectiveness.

Thoughtful design will not only boost market acceptance but also drive technological progress, shaping a future where people and automation coexist seamlessly in healthcare and beyond.

If i get more time.....

App Interactive System

Real-time drone status monitoring (battery level, flight path, transport progress).
Remote control and mission planning (preset routes, manual destination adjustment).
Data visualisation and analysis (flight records, medical supplies transport statistics).
User-friendly interface (simplify operation and improve ease of use).

UAV parachute system

Automatically deployed in emergency situations to prevent crashes from harming people or property.
Lightweight parachute material, ensuring safety without adding too much weight.
Intelligent trigger mechanism, combined with sensors to detect drone failures and respond quickly.
Regulatory compliance ensures that the parachute system meets aviation safety standards and increases user trust.

Black box data recording system

Stores flight data and provides accident tracking and analysis capabilities.