

RESEARCH CONCEPT

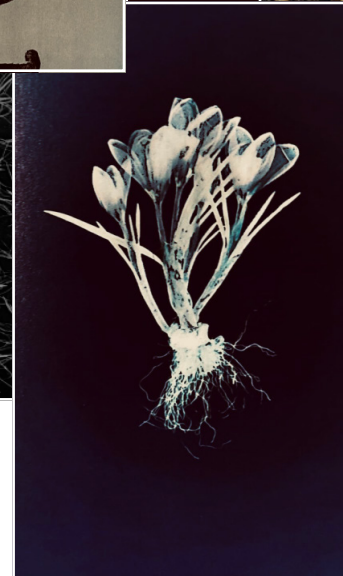
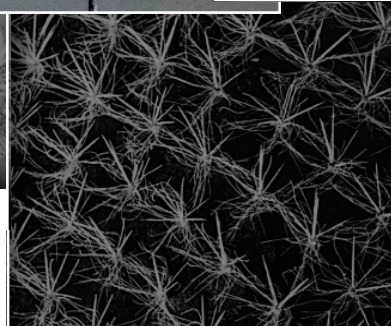
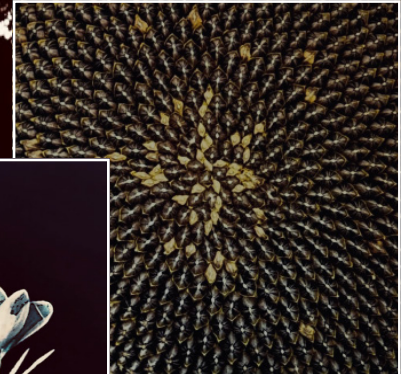
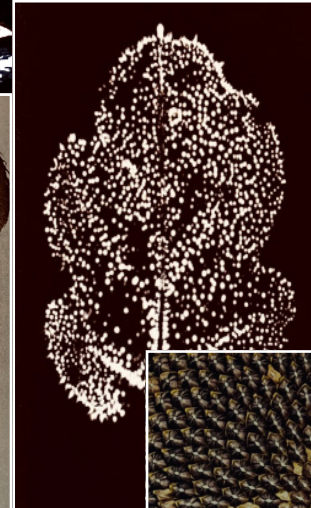
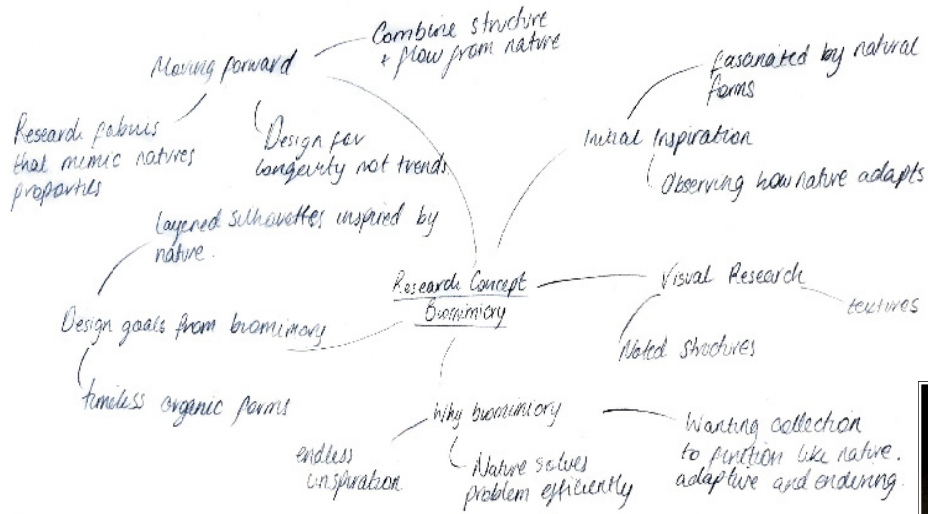

As we look at the plates in this book we soon make a curious discovery: Nature uses the same ideas in her forms and patterns in quite different places. Inexhaustible though Nature is in designing shapes, she may use the same design in various aspects—on a large scale and on a small scale, in minerals and in plants, in animals and in the immense spaces of the earth and the sky. The aerial photograph of a river estuary resembles a plant with its stem, its leaves, and its flowers, and the forked lightning striking from the sky displays a similar branching pattern.

CONCEPT DEVELOPMENT

LILY WILSON PORTFOLIO

TEXTURE RESEARCH

Rocky textures echo vintage leather's rugged, cracked aesthetic for design.

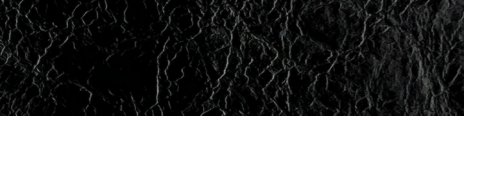
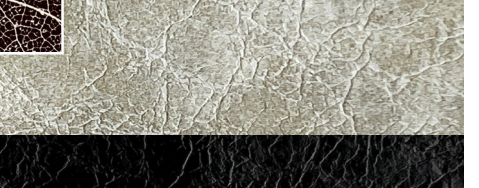
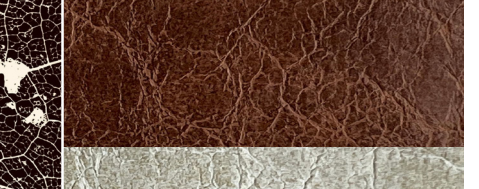
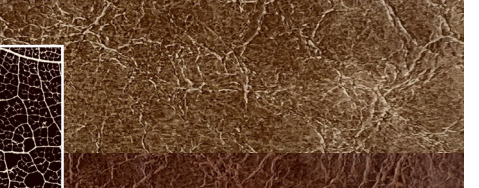
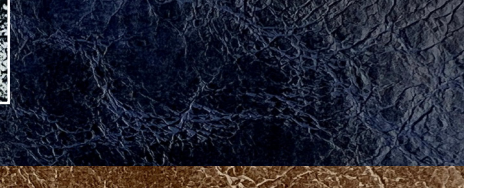
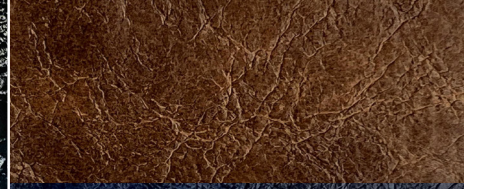
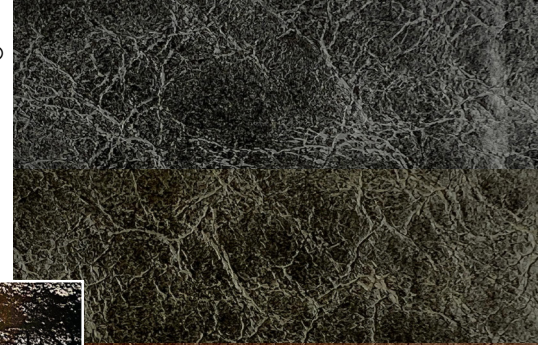
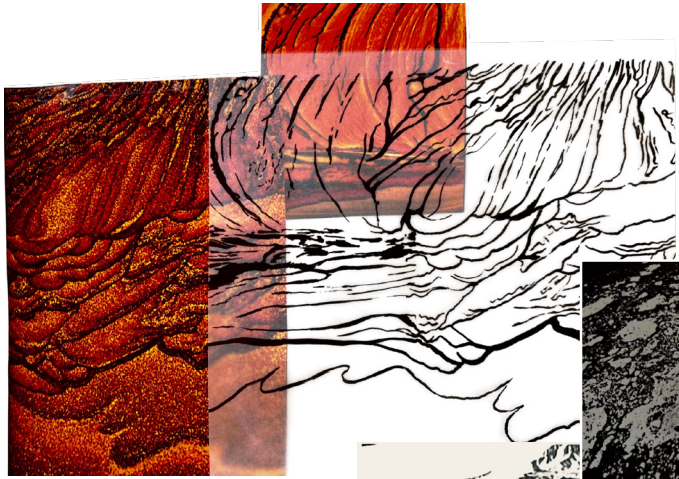

CONCEPT DEVELOPMENT

LILY WILSON PORTFOLIO

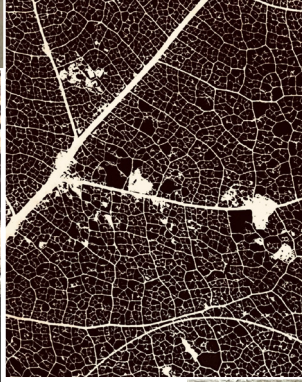
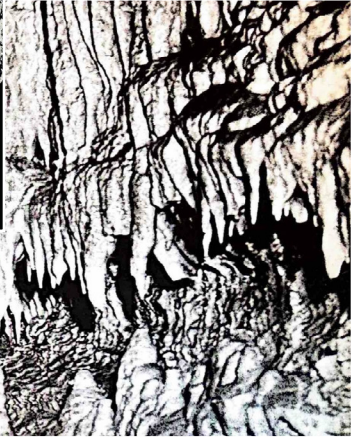
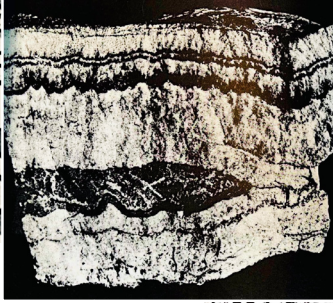
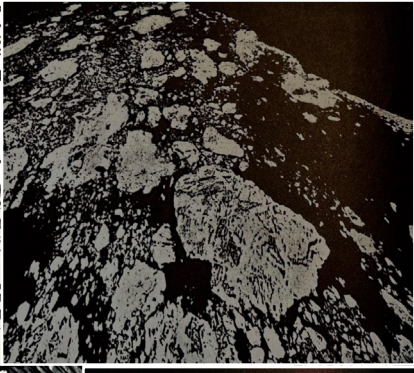

TEXTURE RESEARCH

Alexander McQueen's
beetled linen

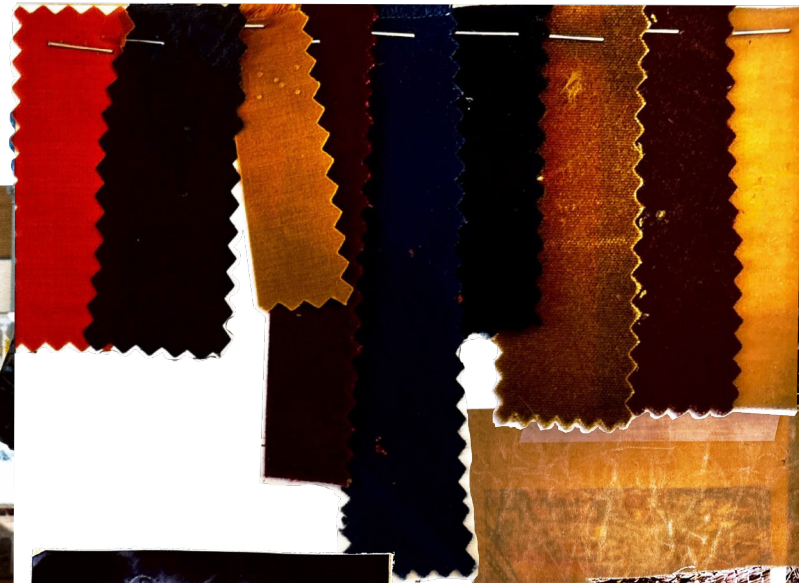

Waxed Cotton
Samples



I was initially drawn to the lustrous finish of Alexander McQueen's beetled linen, but it was too expensive. Instead, I used waxed cotton, crumpling it to create wear marks that reflect the aged textures in my research imagery.

CONCEPT DEVELOPMENT

LILY WILSON PORTFOLIO

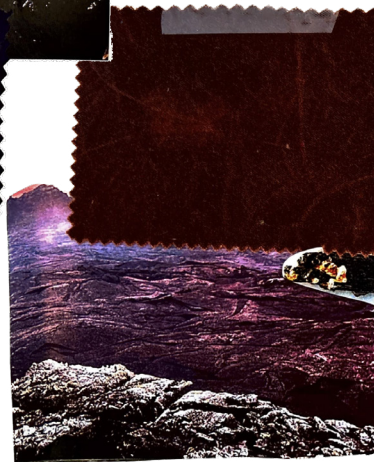

FINAL CONCEPT BOARD

CONCEPT DEVELOPMENT

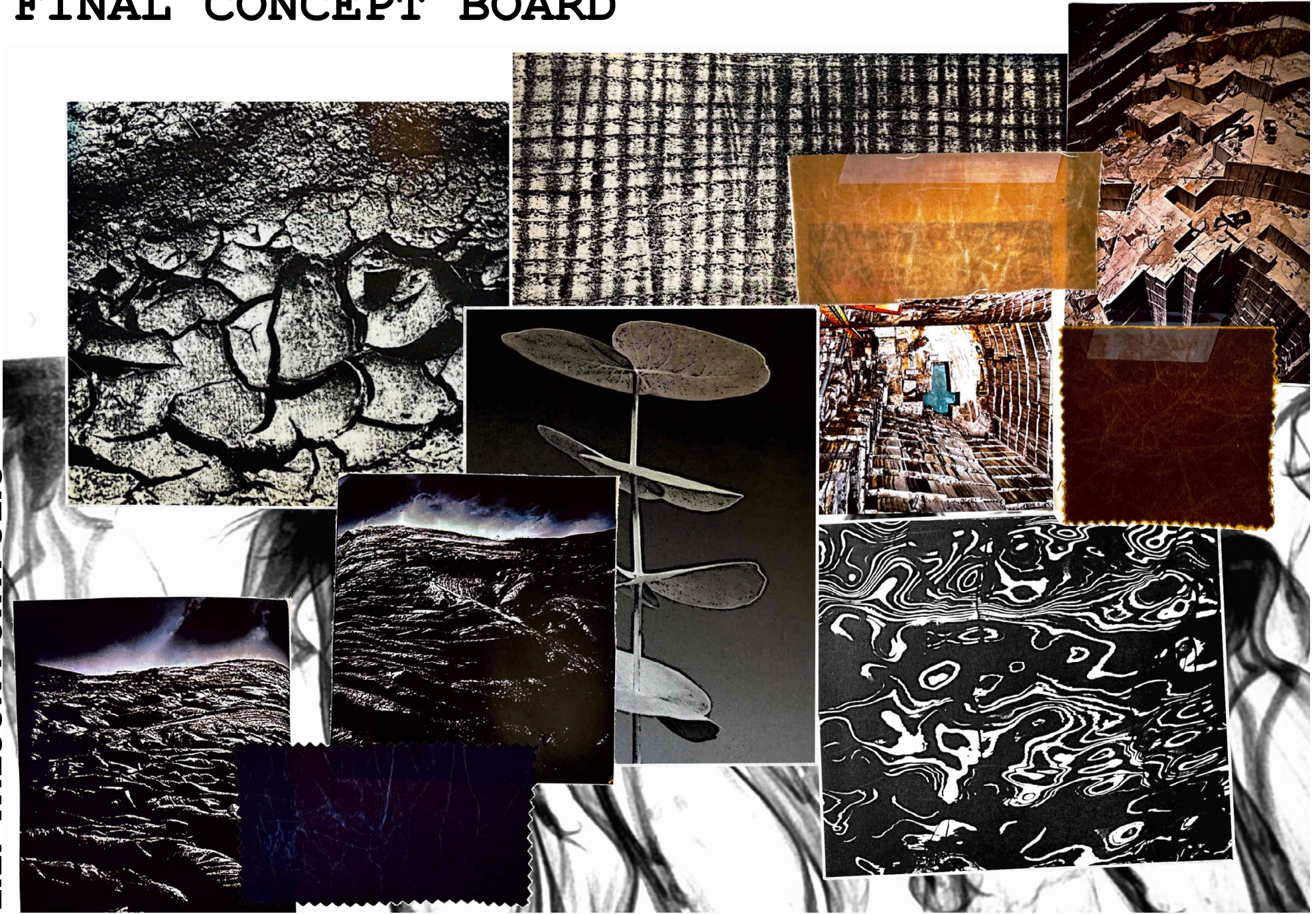

LILY WILSON PORTFOLIO

FINAL COLOUR AND FABRICS

KEY MATERIALS (IN ORDER):
VISCOSE RAYON JERSEY
VISCOSE JERSEY
WOOL BLEND JERSEY
WAXED COTTON
WOOL BLENDS
PU (COATED) VEGAN LEATHER

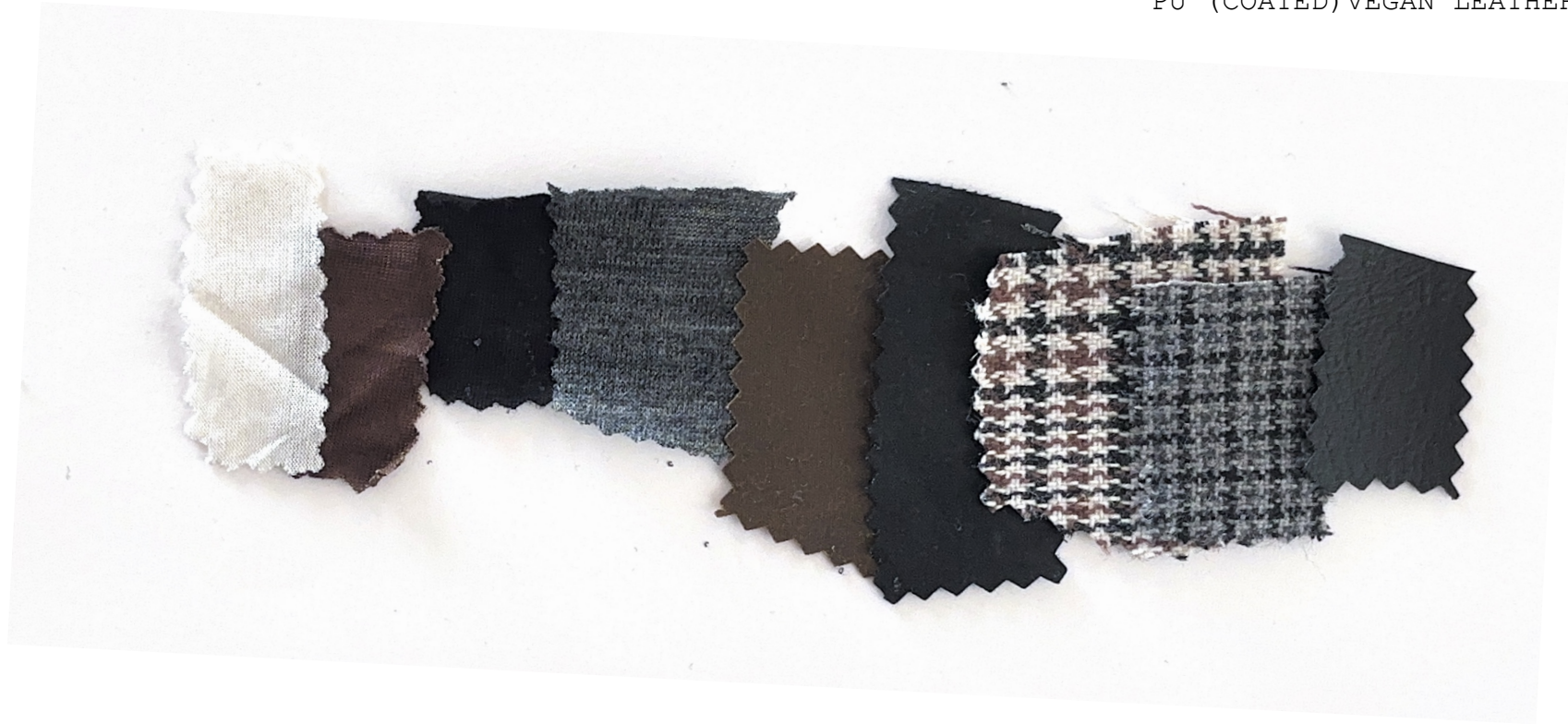

SILHOUETTE DEVELOPMENT

DESIGN DEVELOPMENT

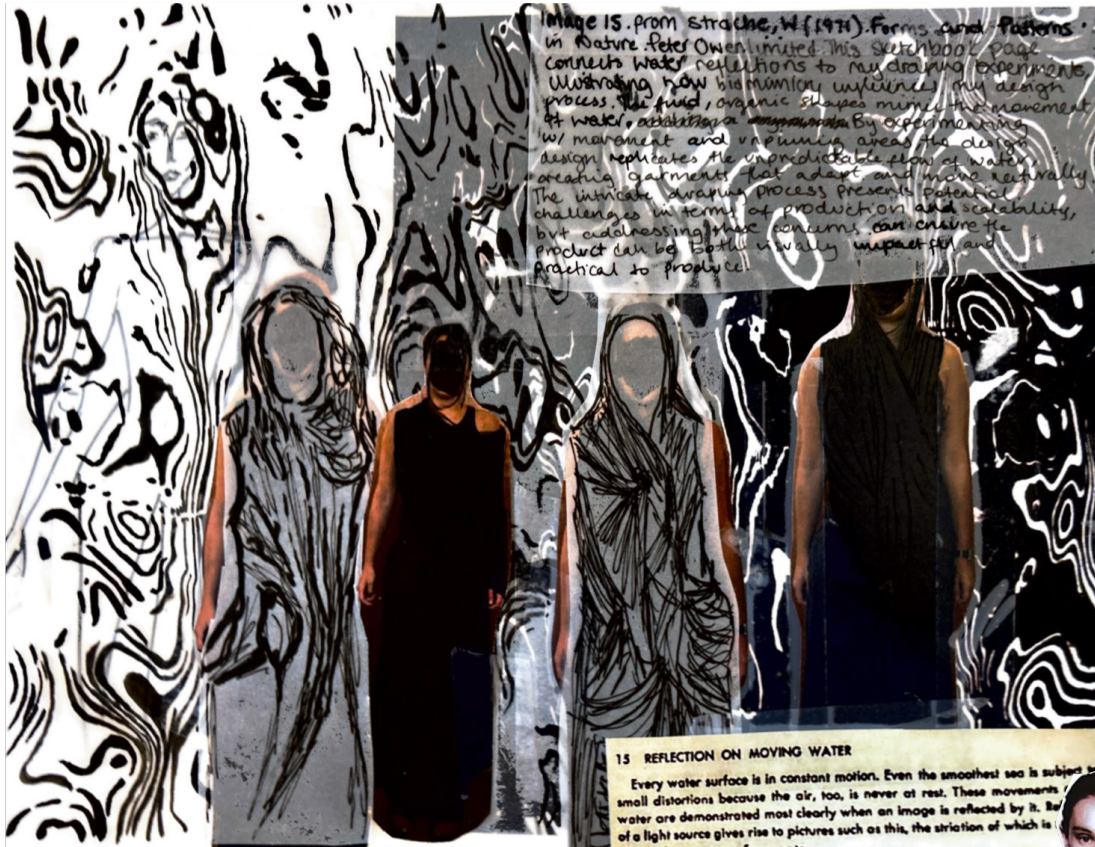

15 REFLECTION ON MOVING WATER

Every water surface is in constant motion. Even the smoothest sea is subject to small distortions because the air, too, is never at rest. These movements of water are demonstrated most clearly when an image is reflected by it. But of a light source gives rise to pictures such as this, the striation of which is

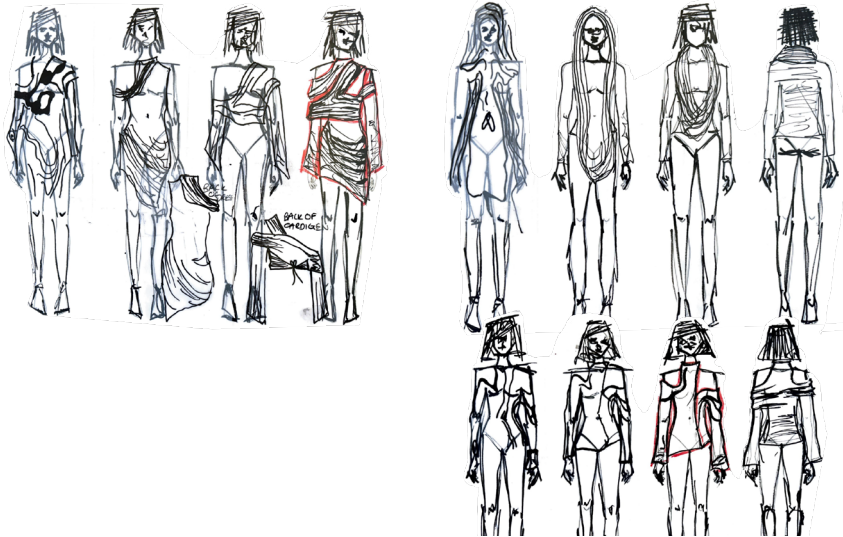

LILY WILSON PORTFOLIO

**FINAL
LINE-UP**

FRONT



BACK



RANGE PLAN - COLOUR



NAME: 3-PIECE DRAPED TOP
CODE: AWB027524-001
MATERIAL: 100% BLEND Jersey
COMP: 90% WOOL, 10% COTTON
PANTONE: 20-0113-PM
PRICE: £100



NAME: HOODED DRAPED TOP
CODE: AWB027524-002
MATERIAL: 100% BLEND Jersey
COMP: 90% WOOL, 10% COTTON
PANTONE: BLACK C
SIZE: 8, 10, 12, 14
PRICE: £100

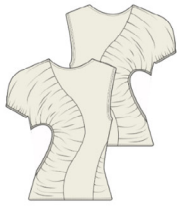

NAME: CUT OUT HOODED TOP
CODE: AWB027524-003
MATERIAL: 100% BLEND Jersey
COMP: 90% WOOL, 10% COTTON
PANTONE: 11-0109-TX
SIZE: 8, 10, 12, 14
PRICE: £110



NAME: HOODED PANEL TOP
CODE: AWB027524-004
MATERIAL: 100% BLEND Jersey
COMP: 90% WOOL, 10% COTTON
PANTONE: 11-0109-TX
SIZE: 8, 10, 12, 14
PRICE: £100



NAME: HOODED PANEL DRAPED TOP
CODE: AWB027524-005
MATERIAL: 100% BLEND Jersey
COMP: 90% WOOL, 10% COTTON
PANTONE: 10-1734-TX
SIZE: 8, 10, 12, 14
PRICE: £100



NAME: TIE BACK DRAPED TOP
CODE: AWB027524-006
MATERIAL: 100% BLEND Jersey
COMP: 90% WOOL, 10% COTTON
PANTONE: 20-0113-PM
SIZE: 8, 10, 12, 14
PRICE: £110



NAME: WAIST CUT DRAPED TOP
CODE: AWB027524-007
MATERIAL: 100% BLEND Jersey
COMP: 90% WOOL, 10% COTTON
PANTONE: 11-0109-TX
SIZE: 8, 10, 12, 14
PRICE: £110



NAME: 3/4 LENGTH PLEATED SHORTS
CODE: AWB027525-001
MATERIAL: WOOL BLEND
COMP: 90% WOOL, 10% POLYESTER
MULTI COLOUR
SIZE: 8, 10, 12, 14
PRICE: £100



NAME: HOODED WRAPLEAF TROUSERS
CODE: AWB027525-002
MATERIAL: 100% BLEND Jersey
COMP: 90% COTTON, 10% WOOL
PANTONE: BLACK C
SIZE: 8, 10, 12, 14
PRICE: £100



NAME: 3/4 LENGTH WRAP PLEATED SHORTS
CODE: AWB027525-003
MATERIAL: WOOL BLEND
COMP: 90% WOOL, 10% POLYESTER
MULTI COLOUR
SIZE: 8, 10, 12, 14
PRICE: £100



NAME: PLEATED PANEL SHORTS
CODE: AWB027525-004
MATERIAL: WOOL BLEND
COMP: 90% WOOL, 10% POLYESTER
MULTI COLOUR
SIZE: 8, 10, 12, 14
PRICE: £100



NAME: APOLOKE LONG SLEEVES
CODE: AWB027525-005
MATERIAL: 100% COTTON Jersey
COMP: 70% POLYESTER, 30% COTTON
PANTONE: BLACK C
SIZE: 8, 10, 12, 14
PRICE: £100



NAME: 3/4 LENGTH PLEATED SHORTS
CODE: AWB027525-006
MATERIAL: WOOL BLEND
COMP: 90% WOOL, 10% POLYESTER
MULTI COLOUR
SIZE: 8, 10, 12, 14
PRICE: £100



NAME: NEW WRAP PLEATED TROUSERS
CODE: AWB027525-007
MATERIAL: 100% COTTON Jersey
COMP: 90% COTTON
PANTONE: 4002-C
SIZE: 8, 10, 12, 14
PRICE: £100



NAME: PLEATED BELL TROUSERS
CODE: AWB027525-008
MATERIAL: WOOL BLEND
COMP: 90% WOOL, 10% POLYESTER
MULTI COLOUR
SIZE: 8, 10, 12, 14
PRICE: £100



NAME: TALL COLLAR FITTED SHIRT
CODE: AWB027525-009
MATERIAL: 100% BLEND Jersey
COMP: 90% WOOL, 10% POLYESTER
MULTI COLOUR
SIZE: 8, 10, 12, 14
PRICE: £100



NAME: TALL COLLAR FITTED JACKET
CODE: AWB027525-010
MATERIAL: 100% COTTON Jersey
COMP: 70% POLYESTER, 30% COTTON
PANTONE: BLACK C
SIZE: 8, 10, 12, 14
PRICE: £100



NAME: SLEEVELESS FITTED JACKET
CODE: AWB027525-011
MATERIAL: 100% COTTON Jersey
COMP: 90% COTTON
PANTONE: BLACK C
SIZE: 8, 10, 12, 14
PRICE: £100



NAME: HOODED JACKET
CODE: AWB027525-012
MATERIAL: 100% COTTON Jersey
COMP: 90% COTTON
PANTONE: 4002-C
SIZE: 8, 10, 12, 14
PRICE: £100



NAME: HOODED DRAPED TOP
CODE: AWB027525-013
MATERIAL: 100% COTTON Jersey
COMP: 70% POLYESTER, 30% COTTON
PANTONE: BLACK C
SIZE: 8, 10, 12, 14
PRICE: £100

LILY WILSON															
STYLE NAME:	OVERSIZED SHORTS WITH PLEATS	SEASON:	SS25 DROP 2	FABRIC:	WOOL BLEND	BARELY									
STYLE CODE:	BARELY252C-003	DESCRIPTION:	3/4 LENGTH, SIDE KNIFE PLEATS	FABRIC COMP:	78% WOOL 22% POLYESTER										
		SIZE RANGE:	6 - 14 (SAMPLE SIZE - 10)	DESIGNER:	LILY WILSON										

COLOUR PAGE

FRONT

BACK

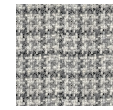

MULTI COLOUR

COLOURWAY:	COLOURWAY 1
FABRIC COLOUR:	MULTI COLOUR - SEE FABRICS PAGE
THREAD:	PANTONE BLACK C # 2D2926
SNAP BUTTON COLOUR:	PANTONE BLACK C # 2D2926
HOOK & EYE COLOUR:	PANTONE BLACK C # 2D2926

LILY WILSON	LILY WILSON	LILY WILSON	LILY WILSON	LILY WILSON	LILY WILSON	LILY WILSON	LILY WILSON	LILY WILSON	LILY WILSON	LILY WILSON	LILY WILSON	LILY WILSON	LILY WILSON	LILY WILSON	LILY WILSON
STYLE NAME:	OVERSIZED SHORTS WITH PLEATS	SEASON:	SS25 DROP 2	FABRIC:	WOOL BLEND	BARELY									
STYLE CODE:	BARELY252C-003	DESCRIPTION:	3/4 LENGTH, SIDE KNIFE PLEATS	FABRIC COMP:	78% WOOL 22% POLYESTER										
		SIZE RANGE:	6 - 14 (SAMPLE SIZE - 10)	DESIGNER:	LILY WILSON										

VIEW OF FLY

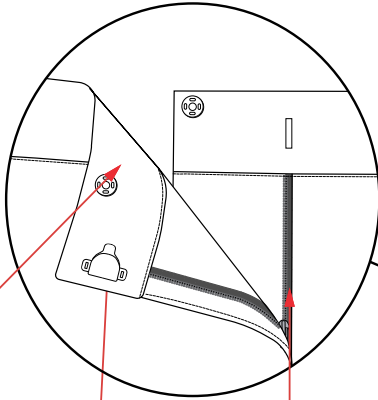

SNAP BUTTON FASTENING
*SEE BOM PAGE

HOOK & EYE FASTENING
*SEE BOM PAGE

NYLON ZIP FASTENING
*SEE BOM PAGE

DETAILS PAGE

*SEE IMAGERY PAGE FOR REFERENCE

FRONT

STRAIGHT SET ON WAISTBAND
TO BE 4CM WIDE

BACK

VIEW OF WAISTBAND

STITCH BELOW CLOSELY TO WAISTBAND
CREATING A CONCEALED SEAM
ENSURING TO CATCH WAISTBAND UNDER

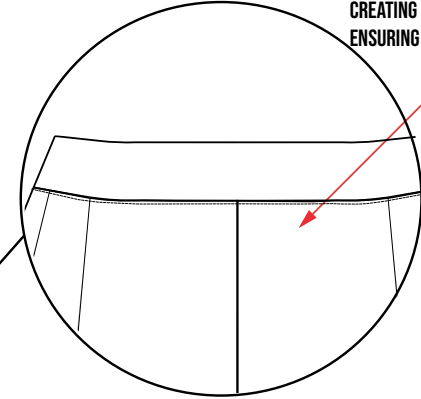

SIDE VIEW OF POCKET

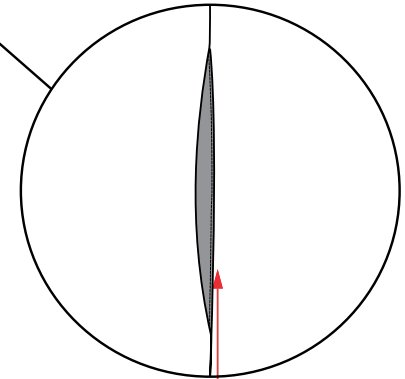

3 KNIFE PLEATS EITHER SIDE, TO BE 4CM WIDE.

3 KNIFE PLEATS EITHER SIDE, TO BE 4CM WIDE.

SINGLE FOLD (2CM SA) OVERLOCKED HEM

CONCEALED INSEAM POCKET
NOTE POCKET HAS BEEN UNDERSTITCHED
*SEE INNER GARMENT PAGE

SELF FABRIC RIGHT SIDE

SELF FABRIC WRONG SIDE

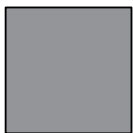
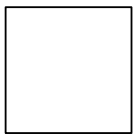

LILY WILSON		LILY WILSON		LILY WILSON		LILY WILSON		LILY WILSON		LILY WILSON		LILY WILSON		LILY WILSON	
STYLE NAME:	OVERSIZED SHORTS WITH PLEATS	SEASON:	SS25 DROP 2	FABRIC:	WOOL BLEND	BARELY									
STYLE CODE:	BARELY252C-003	DESCRIPTION:	3/4 LENGTH, SIDE KNIFE PLEATS	FABRIC COMP:	78% WOOL 22% POLYESTER										
		SIZE RANGE:	6 - 14 (SAMPLE SIZE - 10)	DESIGNER:	LILY WILSON										

INNER GARMENT DETAILS PAGE

*SEE IMAGERY PAGE FOR REFERENCE

SINGLE NEEDLE EDGE STITCH WAISBAND

SNIP SA ABOVE AND BELOW POCKET TO PRESS SIDE SEAMS OPEN

FRONT

BACK

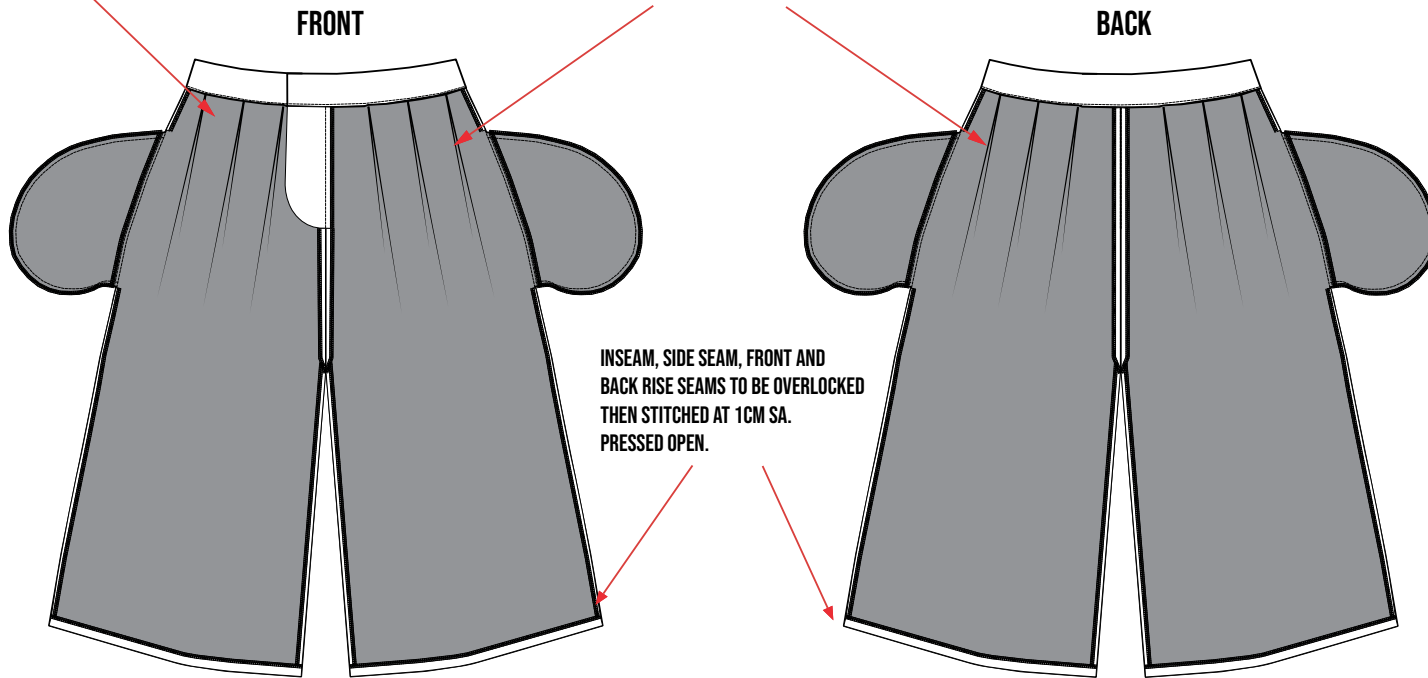

INSEAM, SIDE SEAM, FRONT AND BACK RISE SEAMS TO BE OVERLOCKED THEN STITCHED AT 1CM SA. PRESSED OPEN.

VIEW OF POCKET STITCHING

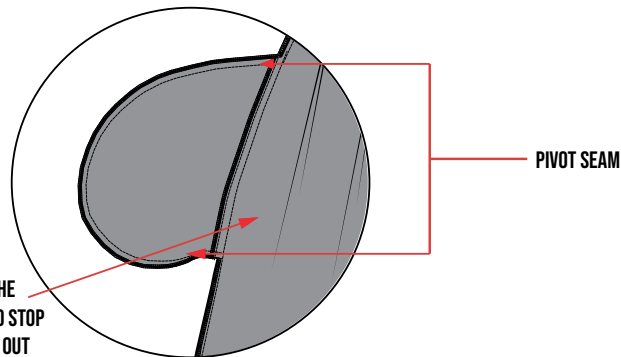

PIVOT SEAM

UNDERSTITCH SA TO THE POCKET BAG 0.3CM FROM THE POCKET ATTACHED SEAM. TO STOP POCKET BAG FROM ROLLING OUT

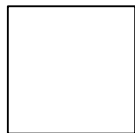

SELF FABRIC RIGHT SIDE



SELF FABRIC WRONG SIDE

LOOK 1



LOOK 2



LOOK 3

