



**KAVYA DHINGRA
STUDIO 10**

TABLE OF CONTENTS

01.

Site Analysis

- Project Brief
- Site Surroundings
- Site Community
- Site environmental Impact
- Material Taxonomy
- Site Contextual Response
- Design Manifesto

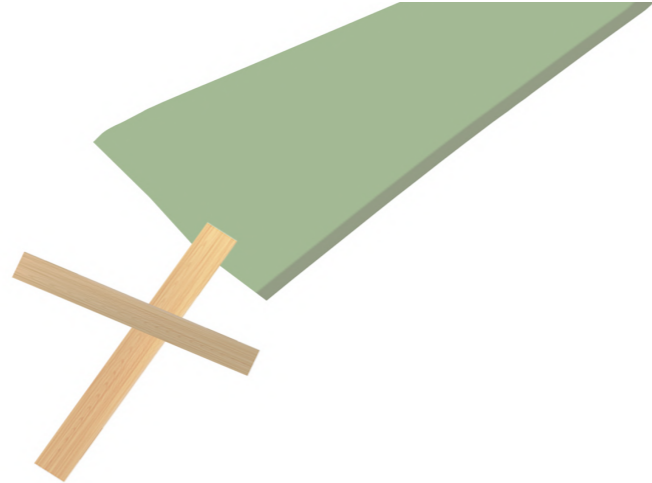

02.

Project Deveopment

- Precedent Study
- Site Materials : Circular Economy
- Precedent Study
- Project Structural Phasing
- Project Function Phasing
- Design Concept Evolution

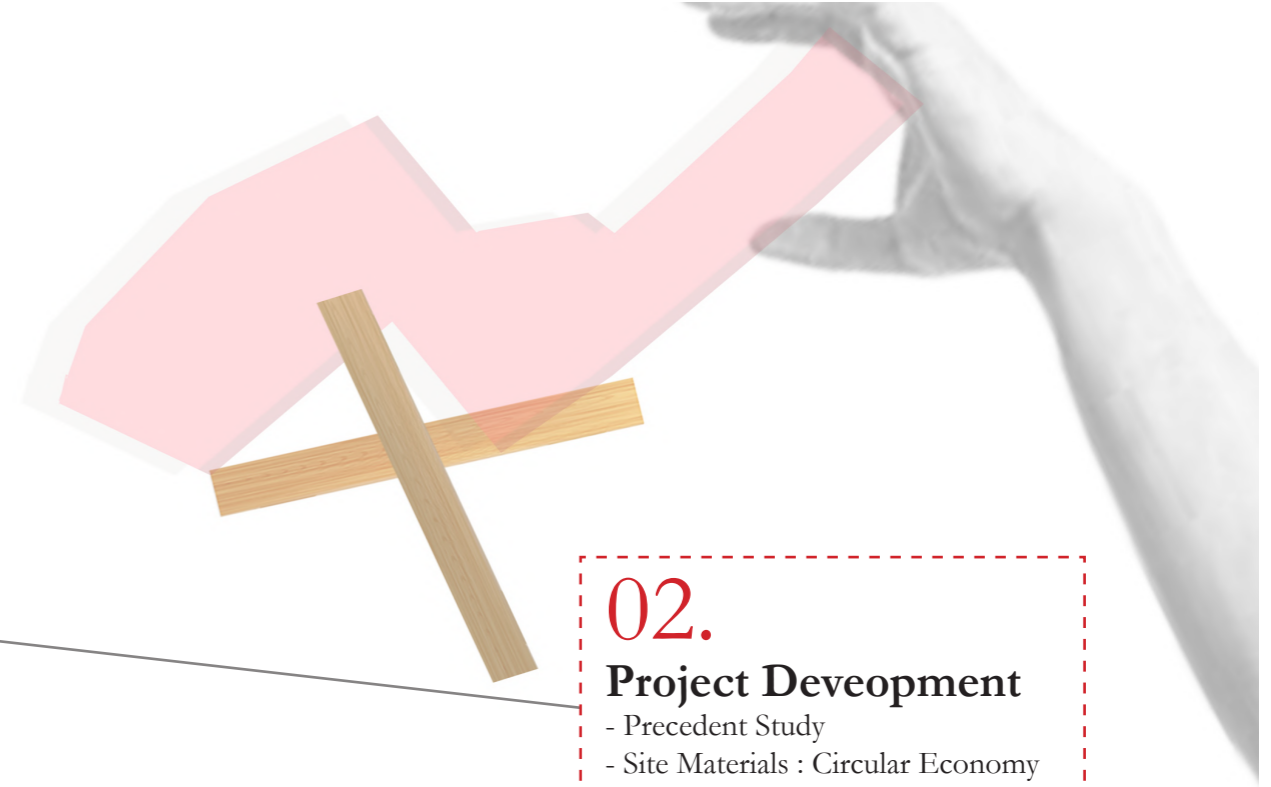

03.

Project Showcase

- Floor plans PHASE 1
- Floor plans PHASE 2
- PHASE 3 Ground floor plan
- PHASE 3 Roof plan
- PHASE 3 plan zoom In
- Phase 3 Elevation 1
- Phase 3 Section 1
- Phase 3 Section 2

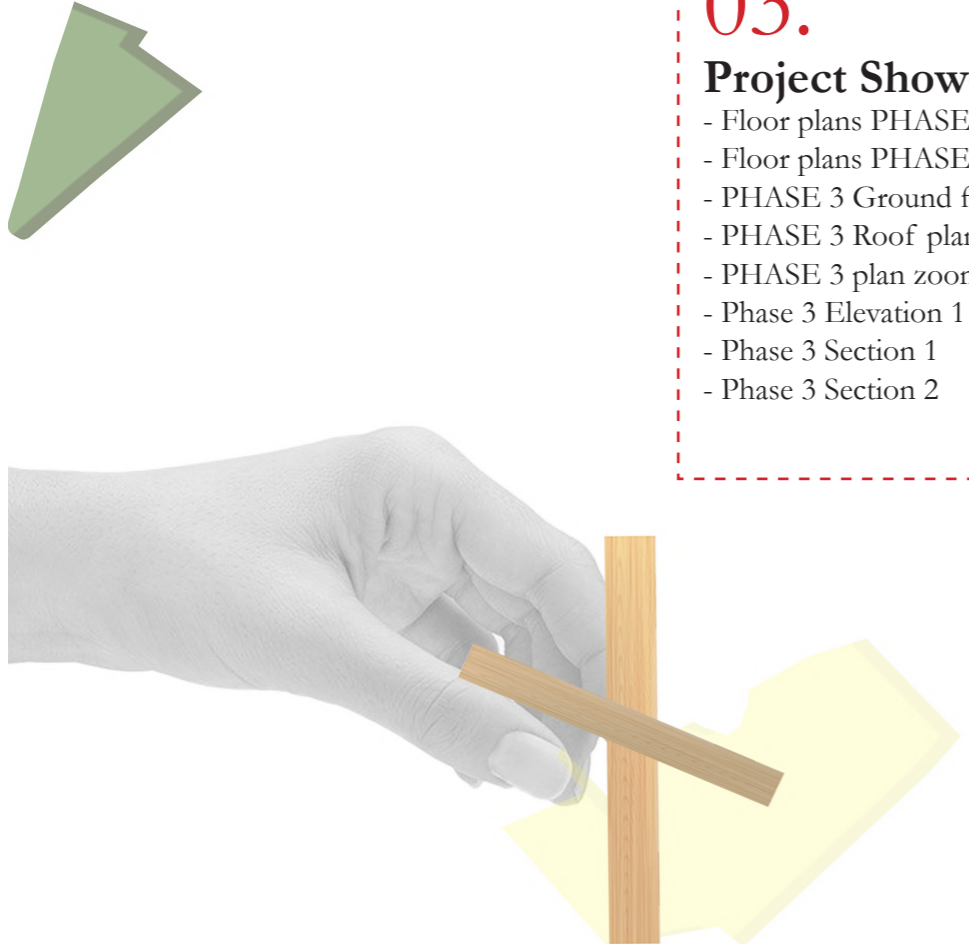

04.

Project Response

- Project Material Details
- Project at 1:20 scale
- Project Exploded Axo per room
- Project use of space
- Project Interior Views
- Project Exterior Views
- Project Well Being analysis
- Project Environmental Analysis





PROJECT BRIEF:

The Eel Pie Island Community Hub is a self-build initiative designed to bring together the island's diverse communities—boat dwellers, artists, and residents—through a shared management and social space. Rooted in sustainability and circular economy principles, this project aims to create a centralized hub that fosters collaboration, preserves the island's cultural identity, and strengthens local resilience against external development pressures. The project is guided by an incremental, self-build approach, inspired by the Segal Method, allowing the community to actively participate in shaping their environment using locally available and reclaimed materials. The hub will function as a multi-use space, integrating a workshop for site maintenance, exhibition areas for artists, a social space for residents, and a materials sorting and reuse station to support ongoing repair work within the boatyards. By prioritizing modular timber construction and adapting to the island's tidal and environmental conditions, the design ensures long-term adaptability and minimal ecological impact. The hub will serve as an anchor for ongoing community-led growth, offering teaching spaces, communal workshops, and a gathering point for knowledge-sharing and skill-building. This project is more than just a physical structure—it is a platform for community empowerment, self-sufficiency, and preservation of Eel Pie Island's unique identity. By fostering a shared sense of ownership and responsibility, the hub will safeguard the island's legacy while ensuring its sustainable future.

EEL PIE ISLAND: Site Access & Surroundings

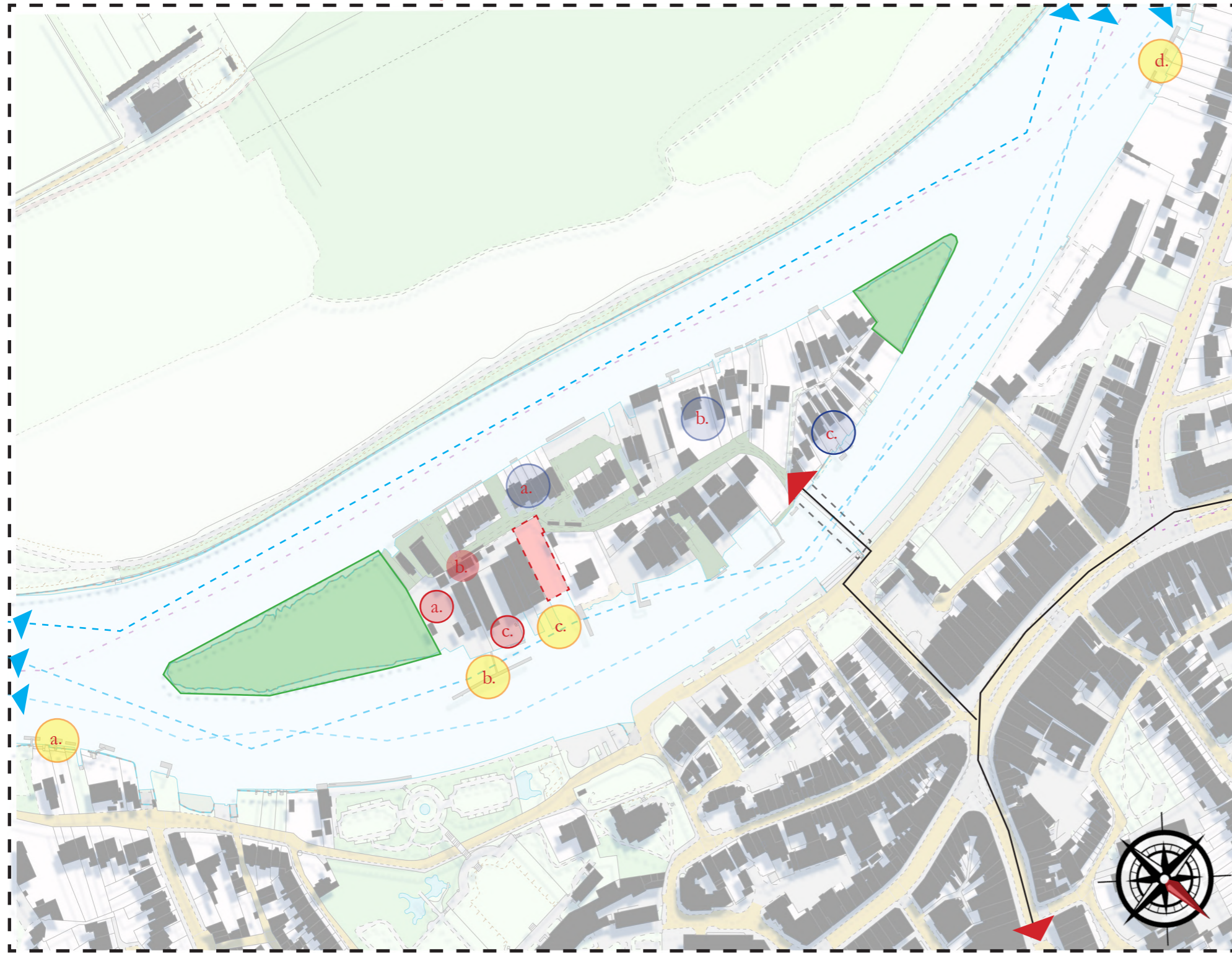

- a. Ferry Yard
- b. Pheonix Wharf
- c. Boatyards (SITE)
- d. Hammerton's Ferry
- a. Site Socialising point : preserved scrap
- b. Lee Art class & Cermaic workshops
- c. Third Party Developed Art Studios
- a. Aquarius Housind : Third party development
- b. Office spaces for external users
- c. Art community residents & AirBNBS
- a. On Site Nature Reserves
- a. Build structures around site
- a. Main Site : Boatyards

- Main Entrance access point
- Boat Paths across the River
- Foot Bridge access to the island

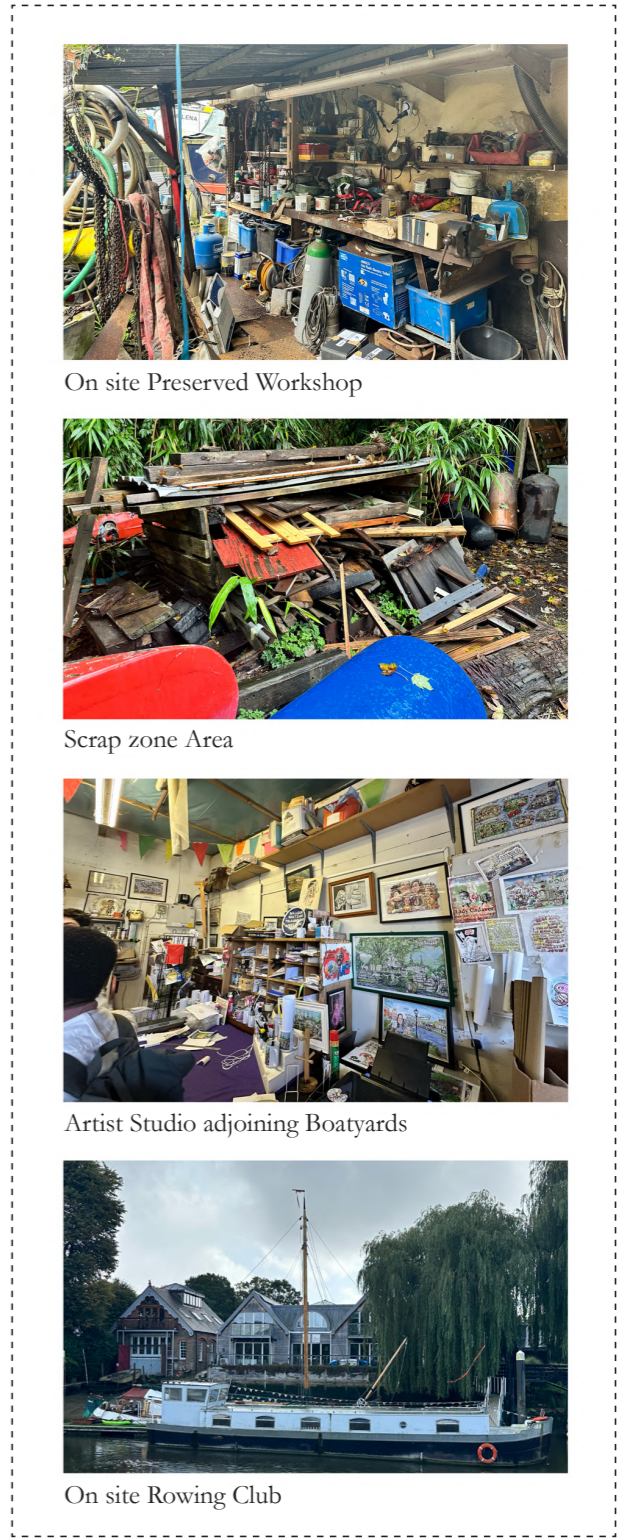
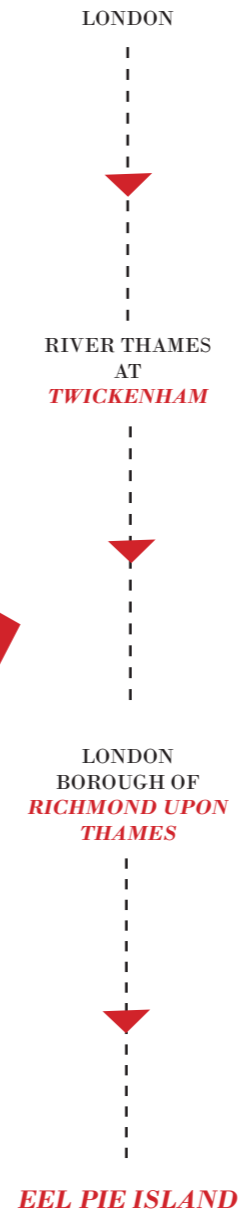

The historical context of the island involves the change of site community over the years and the danger of futuristic extinction due to third party developers aiming to shift the island's focus to a residential space owing to its famous culture. The main focus of the site is the boatyards that are presently on market for development putting the present community of artists and boatdwellers under risk of displacement.

SITE COMMUNITY JUXTAPOSITION: *The evolution of Site Community & reason for preservation*

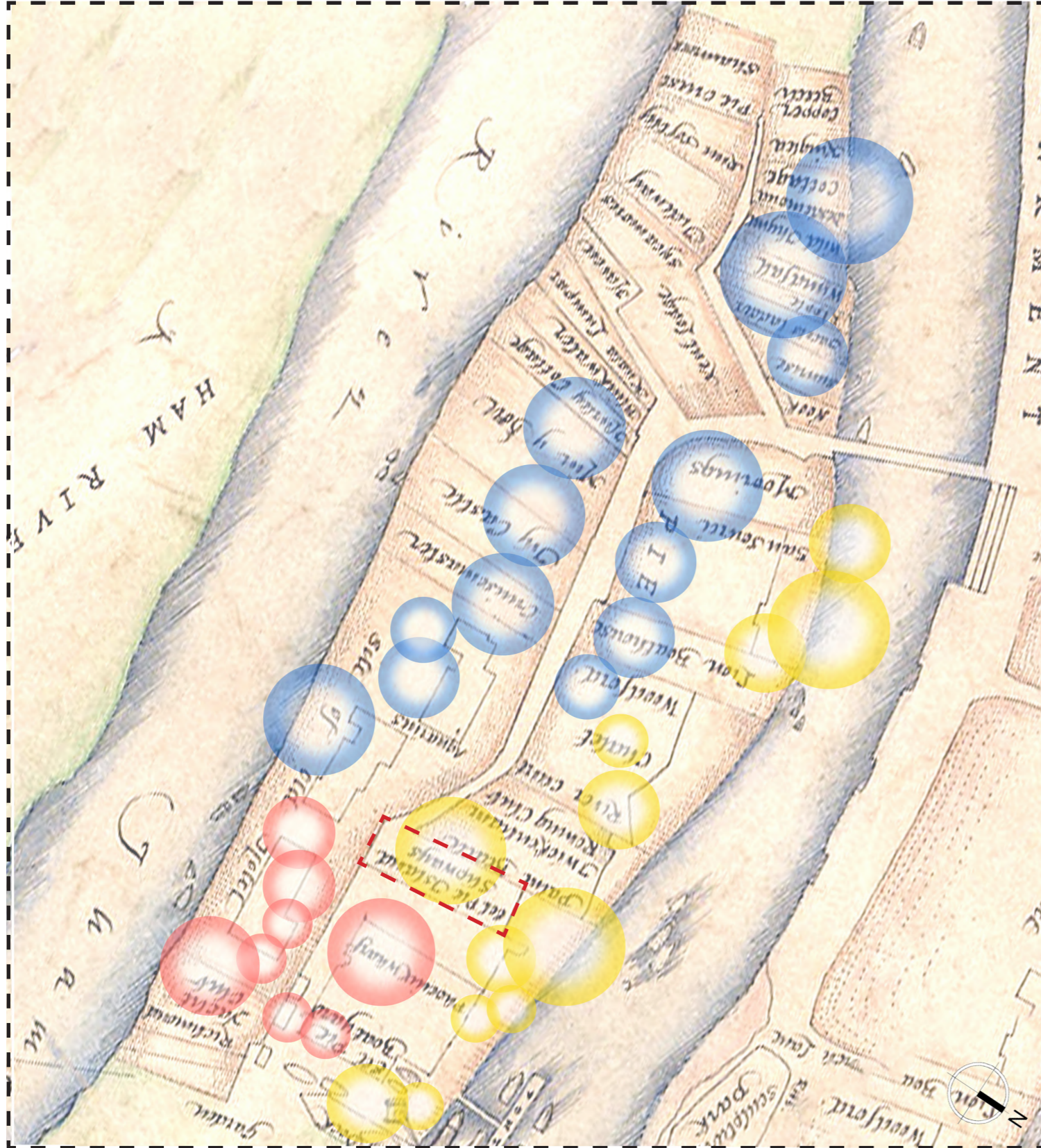

SITE JUXTAPOSITION OF COMMUNITY BALANCE

The markup of the present communities onto a historical map provides the sense of juxtaposition over the decades. The yellow represents the Boatdwellers and the workshop community, the red annotates the on site artists working in their studios while blue denotes the residential community on site gradually taking over the island. Another thing that the map shows in abstract is the community balance ratio of 2:1 where the boat community and artists together build up to be equal to the increased residential community on site.

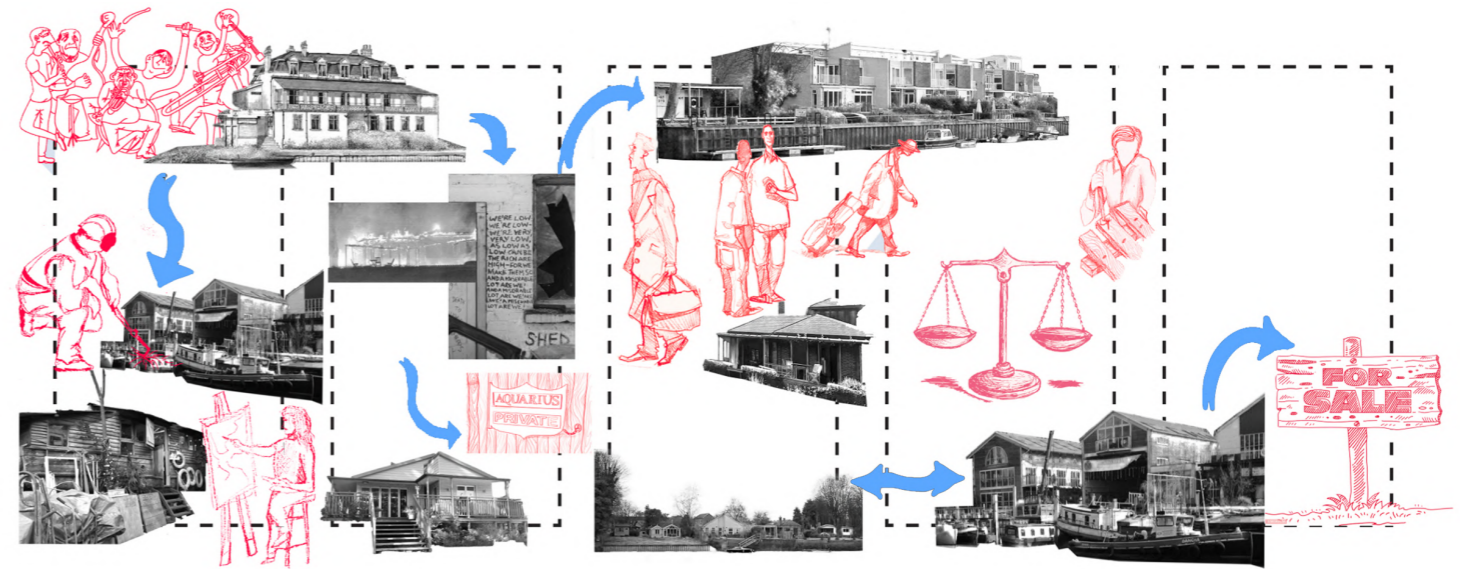

HISTORICAL CONTEXT OF EEL PIE ISLAND

The historical context of the island involves the change of site community over the years and the danger of futuristic extinction due to third party developers aiming to shift the island's focus to a residential space owing to its famous culture. The main focus of the site is the boatyards that are presently on market for development putting the present community of artists and boat dwellers under risk of displacement.

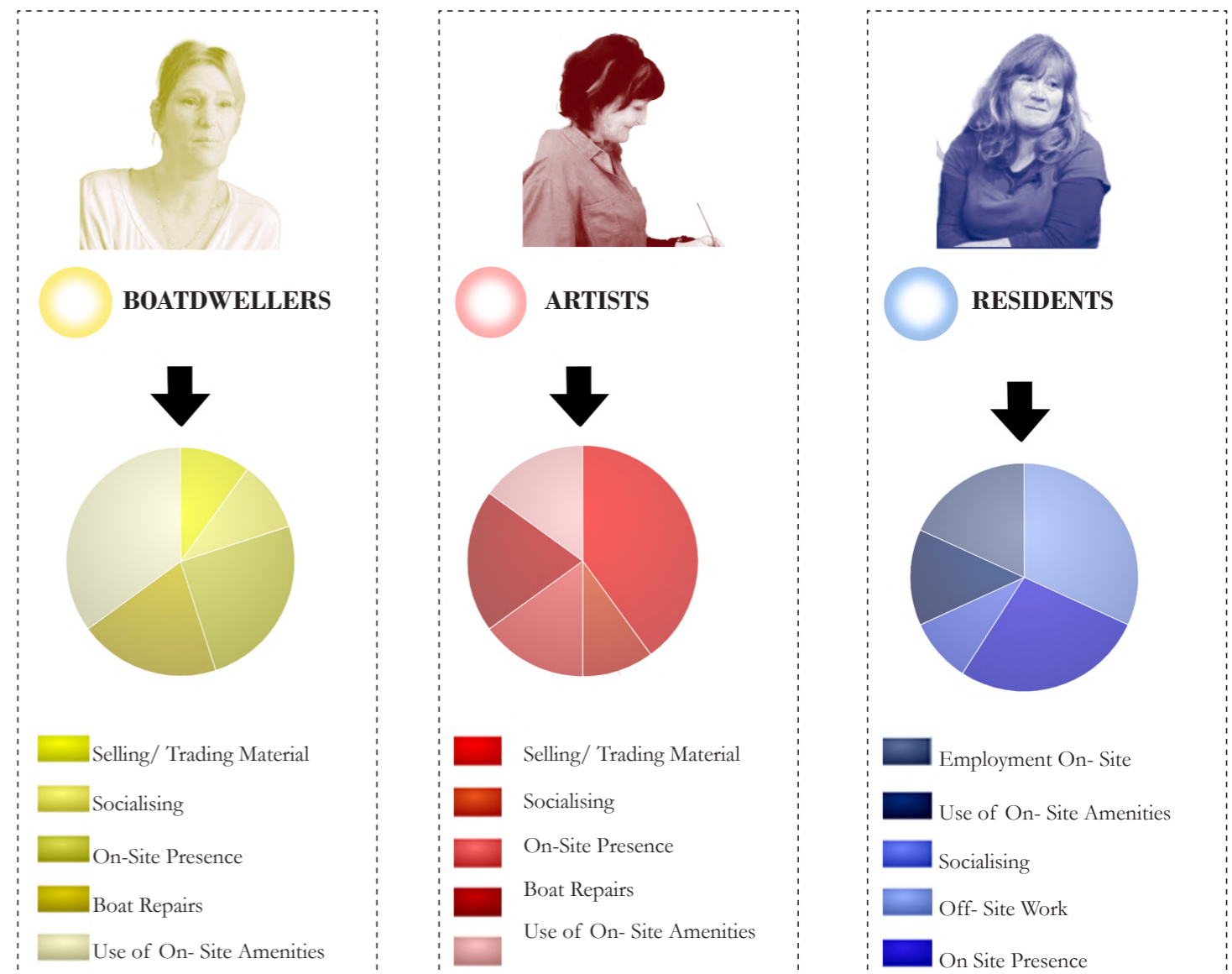

SITE LOCATION AND FLOOD IMPACT : *Is the site and its' locality affected by floods?*

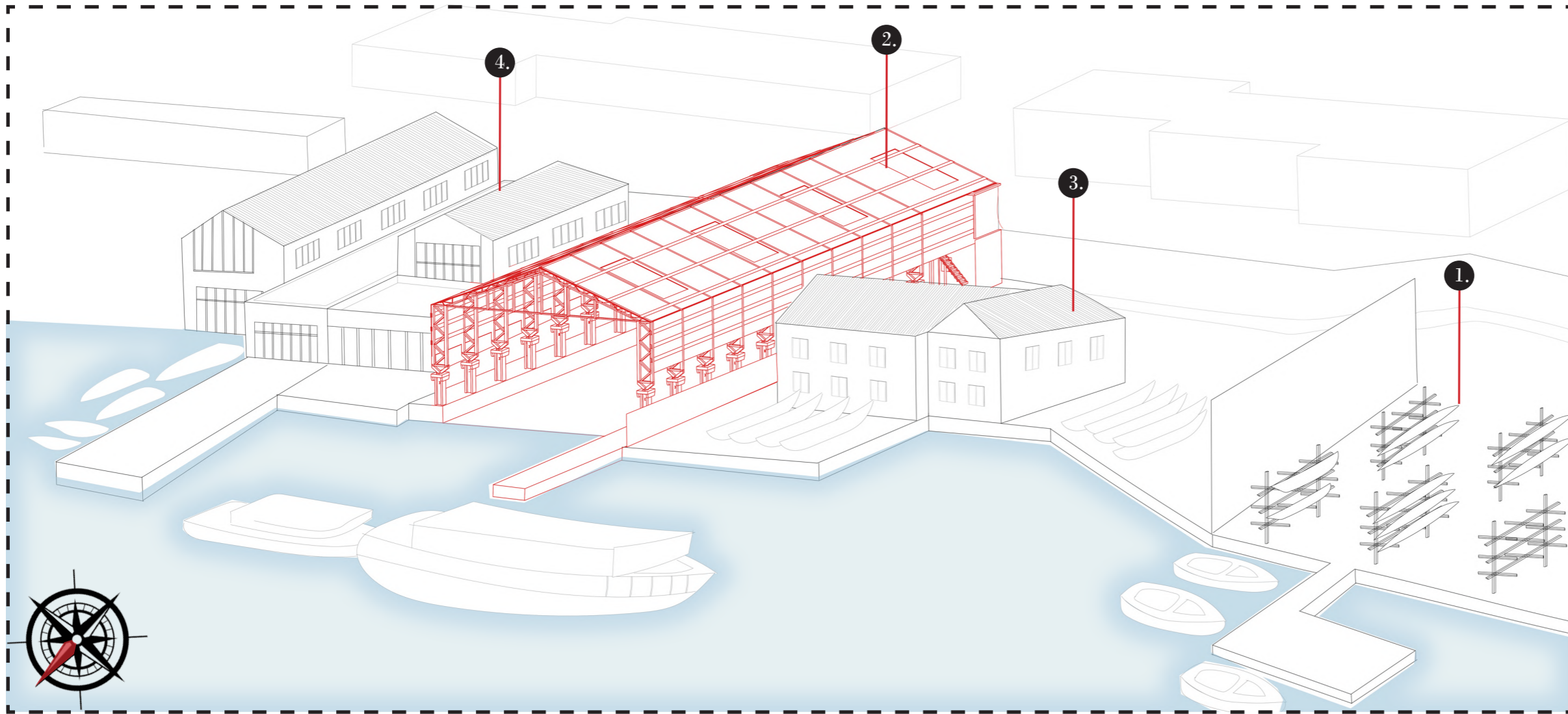

1.

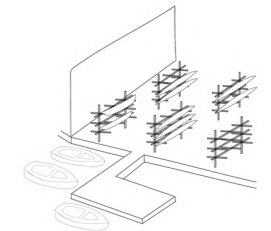

Eel Pie Island Rowing Club

2.

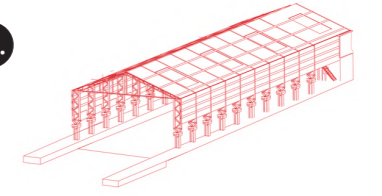

SITE : Eel Pie Island Boatyards

3.

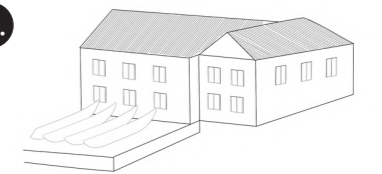

Residential Studios

4.

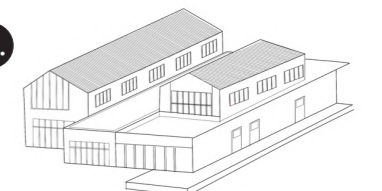

Artist Studios



NEAP TIDE : MORNING HIGH TIDE NEAP TIDE : AFTERNOON LOW TIDE NEAP TIDE : NIGHT HIGH TIDE



SPRING TIDE : MORNING HIGH TIDE SPRING TIDE : AFTERNOON LOW TIDE SPRING TIDE : NIGHT HIGH TIDE



ONE WEEK AFTER FULL MOON



FULL MOON

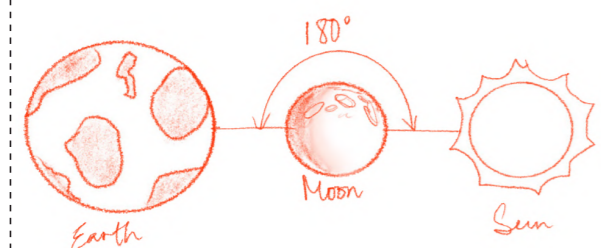

During Neap tides, the ocean's bulge from the sun, which is induced by the moon, is somewhat offset. Consequently, causing a half-moon, therefore reducing the strength of the tides.

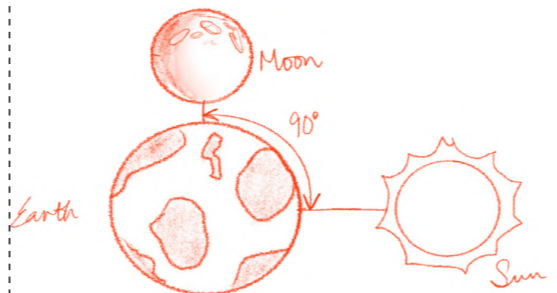

Spring tides are characterized by slightly higher high tides and slightly lower low tides than usual. The sun and moon are at right angles to one another seven days following a spring tide.

◇ PRECEDENT FOR FLOOD CONTROL



Ulatowski, P. (2013), The Edge House

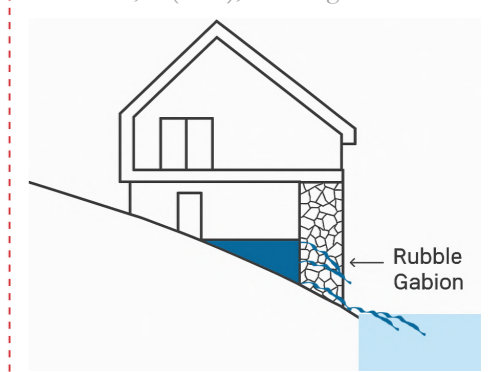

Simplistic sketch for gabion function

◇ The Edge House : Using Gabions for water retaining

CIRCULAR ECONOMY ON SITE : *Material Taxonomy & Material Circular Economy*

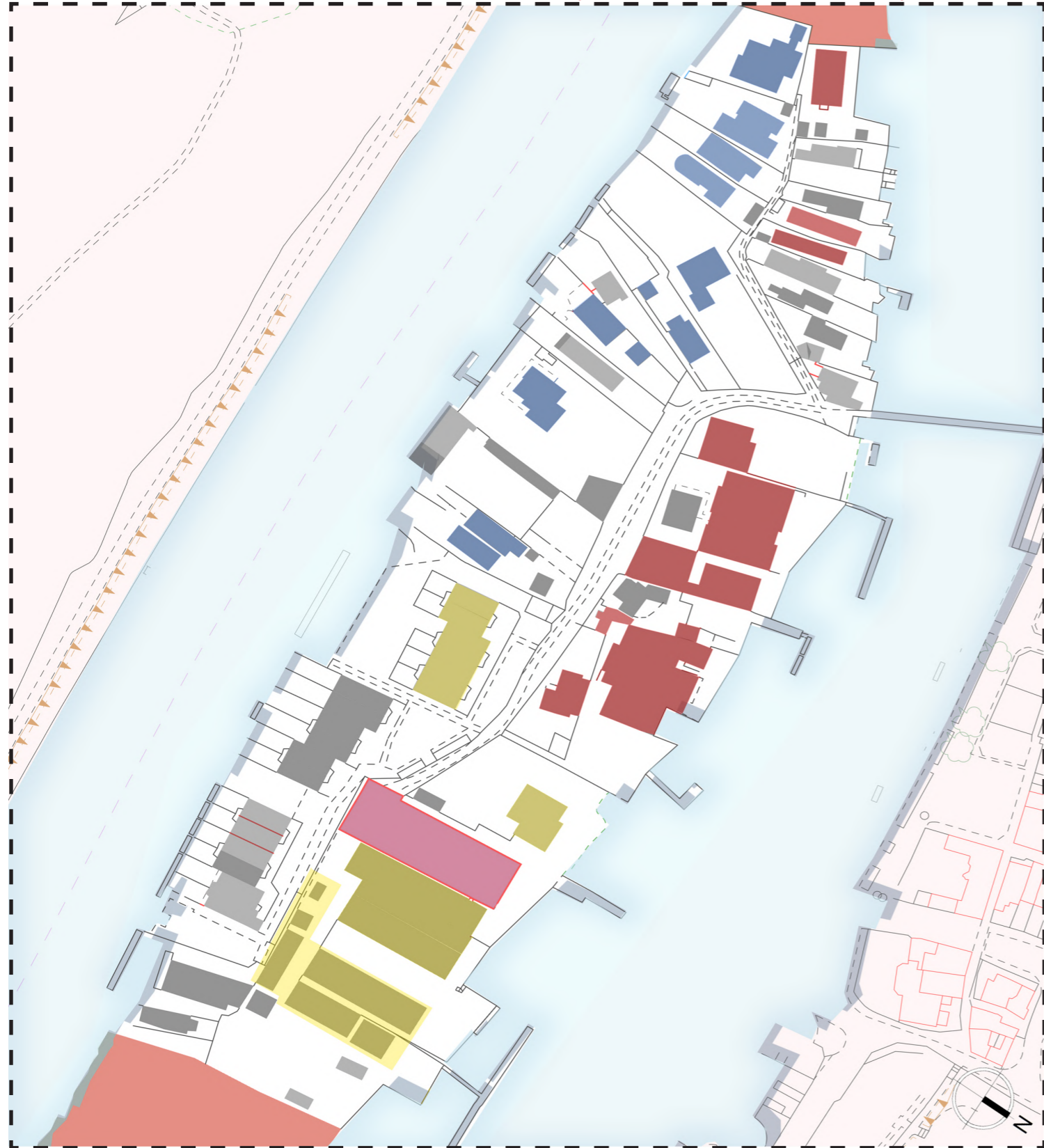

MATERIALS PRESENCE ON SITE



WOODEN MATERIAL ON SITE



METAL MATERIAL ON SITE



BRICK MATERIAL ON SITE

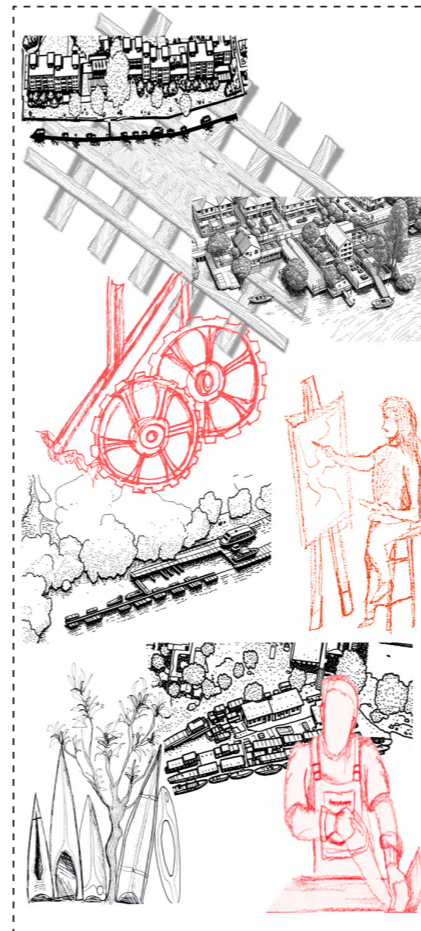

COLLECT

The collection of materials on and around the island to aid the construction on site in minimal waste of material and funds.

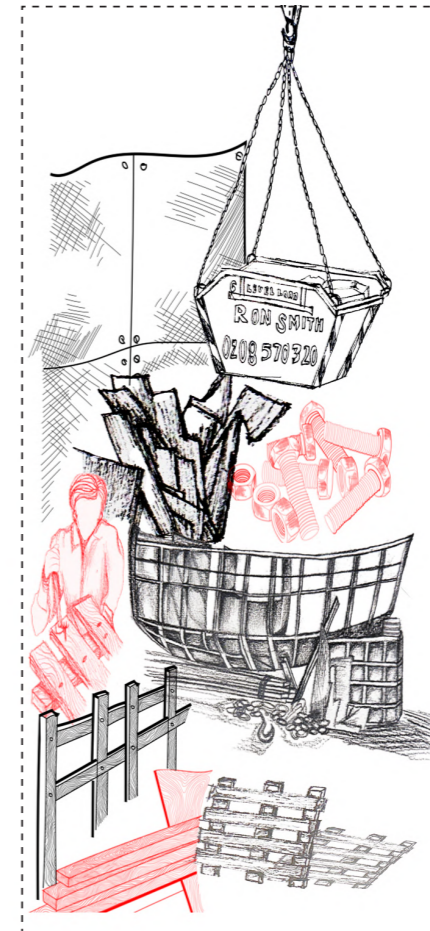

SORT/ BREAKDOWN

The breakdown of premade waste material to obtain raw material to be reused in a new structure, providing an extra material age.

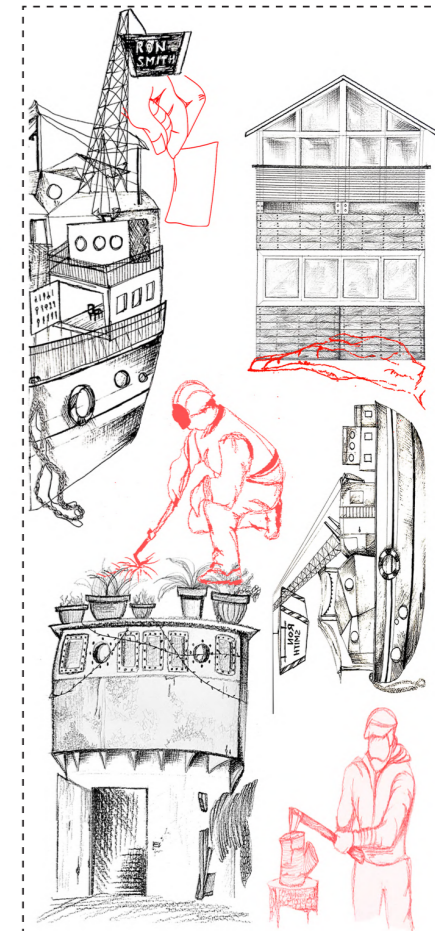

REUSE/ CONSTRUCT

Upcycling sorted materials to construct on site to make the best of restricted funds and using all the scrap present on site.

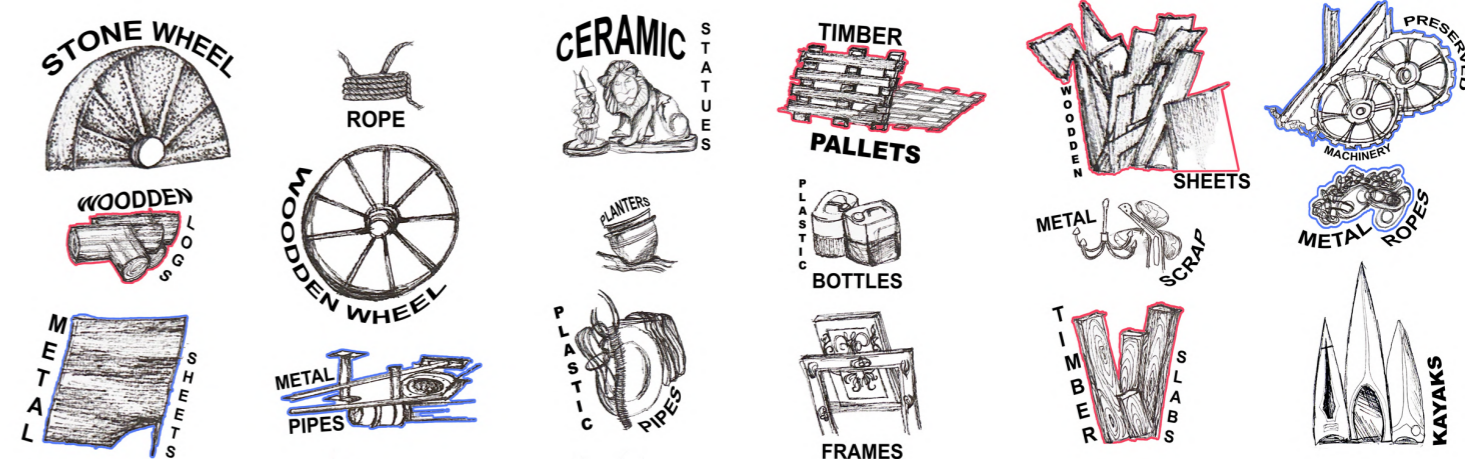

MATERIALS BREAKDOWN PRESENT ON SITE

There is a diverse range of scrap material present on site produced from on-site functions related to artist work and boat repair work that have found their existence on site, slowly overtaking the island space. Thus leaving the island looking less maintained. The taking over of space is mostly to conserve the site's rich heritage of boaters and artists, leaving less space for upcoming artists. To balance the issue at hand, the site needs a well managed showcase space that preserves artist work and advertises the site to obtain funds using the island's talent to raise an island maintenance space to look after the island and its community.

SITE CONTEXTUAL RESPONSE : *Reflecting on the present functions on site*

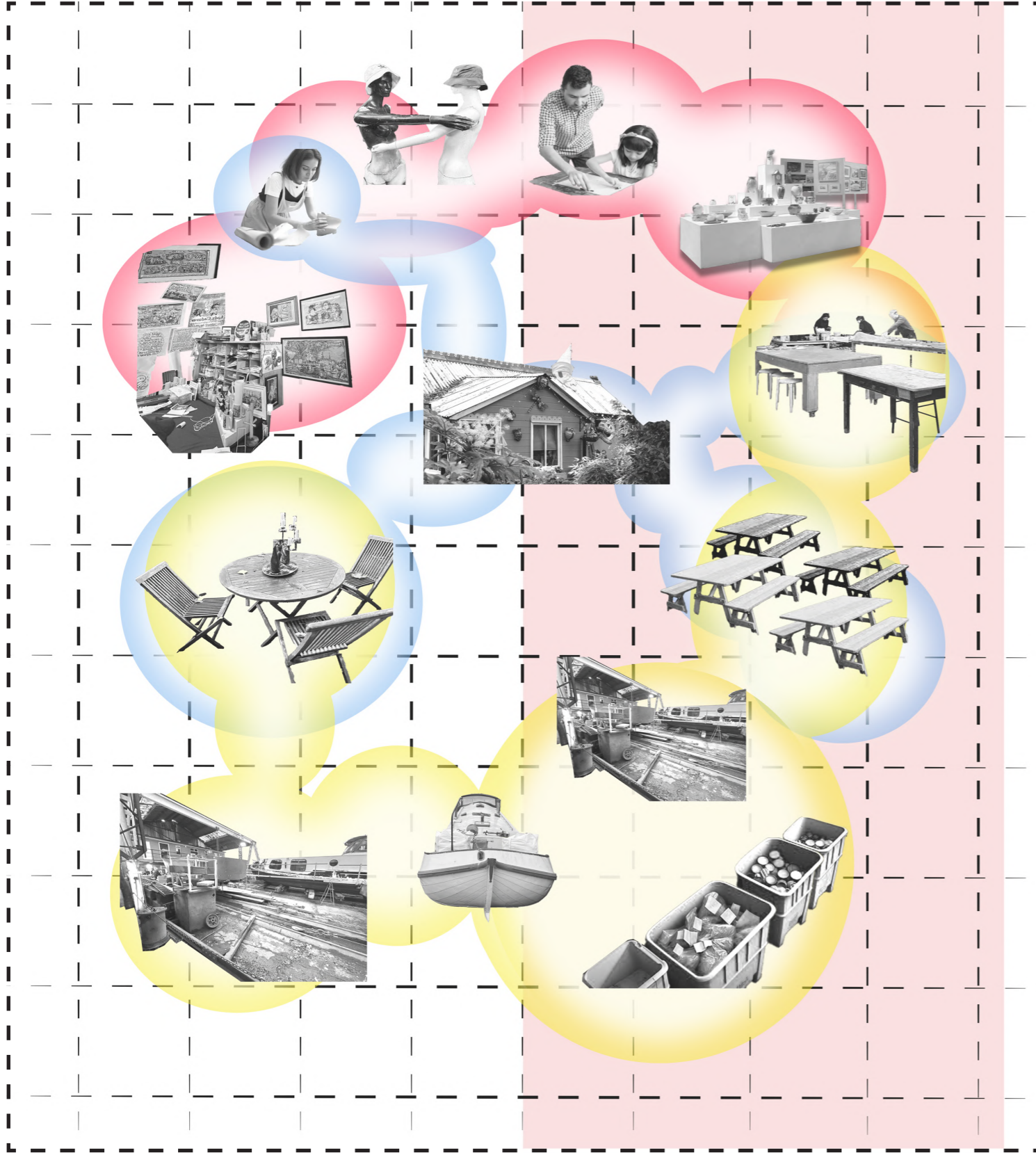

ON-SITE FUNCTIONS

WORKSHOPS - ARTISTS - ARTWORK SCATTERED ON SITE

RESIDENTIAL SPACES - STUDIOS - SOCIAL SPACE

BOATDWELLERS - BOATYARD - SOCIAL SPACE

REQUIRED FUNCTIONS

TEACHING SPACE - EXHIBITION SPACE - COMMUNAL WORKSHOPS

RESIDENTIAL SPACES - COMMUNITY STUDIOS - SOCIAL COMMUNITY SPACE

MATERIAL SORTING SPACE - BOATS - BOATYARD (PRESERVED) - COMMUNITY SPACE - TEACHING



DISPLAY PLATFORM FOR OPEN DAYS

Boatyard site used as display zone on open days with the scrap on site



Provision of a common display space to advertise site community



EXCESS BOATYARD MATERIAL

Excess material collected for boat repair lies around the boatyard as scrap collection



A method to integrate waste material on site without wasting excess to respect funding



PLATFORM TO INTEGRATE EXCESS ART MATERIAL

The art studios are too small to conduct art classes in private work studios on site

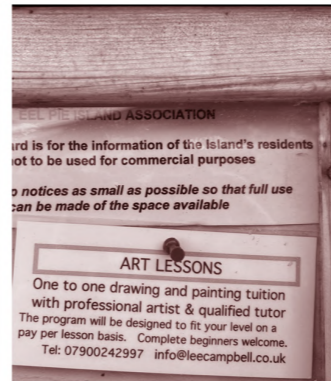

Providing open bookable spaces for management of space for art classes on site



WORKSHOP SPACES FOR BOATS

Not accessible for overall site management due to community disturbances



A common workshop/tool space for not only boats but for site management and growth



A COMMUNAL SOCIAL SPACE

Lies away from residential contact and is too restricted with the scrap collected on site



A space to entertain all communities on site to merge the community barriers



RESIDENTIAL COMMUNITY SECLUDED

The residential community is secluded due to the lack of a proper socialising space



A social space to entertain residents owing to its location and construction

SELF-BUILD MANIFESTO: *Ideology of the Design Proposal*

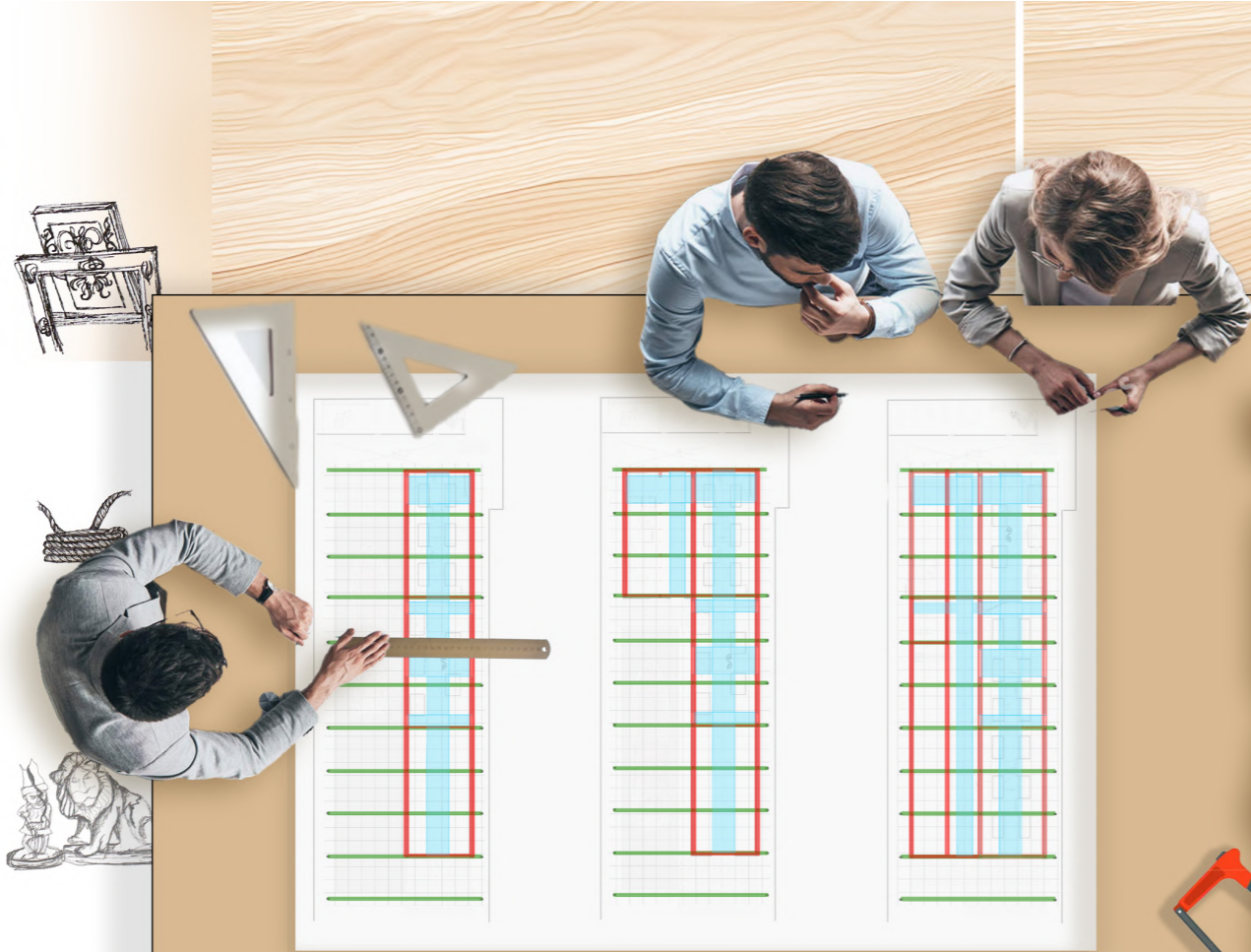
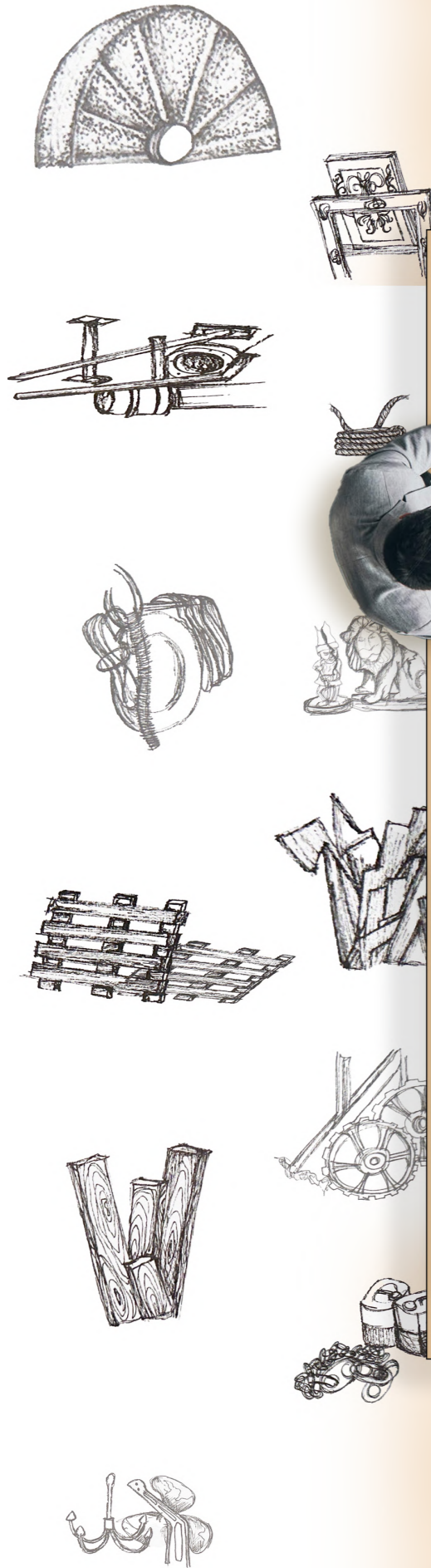

GRID FOLLOWED FOR PROPOSAL PLANNING

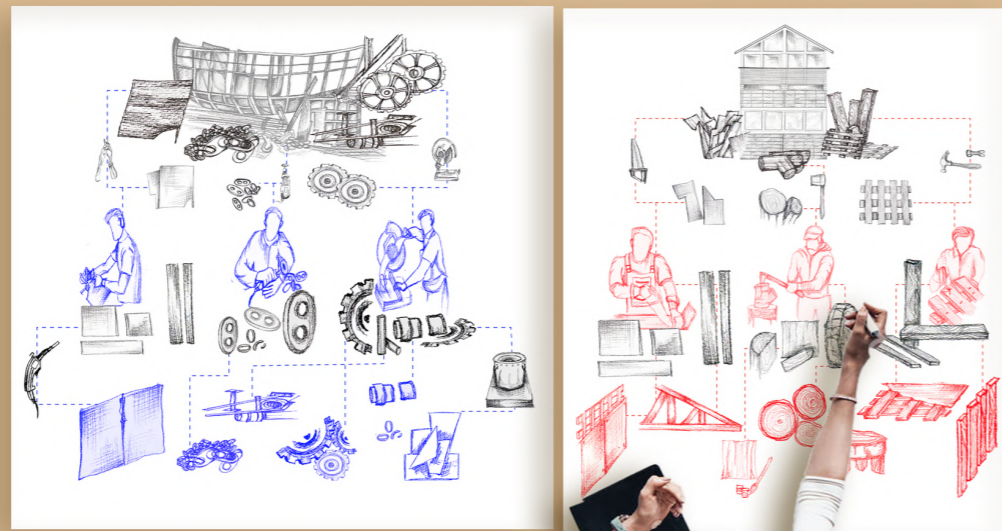

MATERIAL CIRCULAR ECONOMY ON SITE

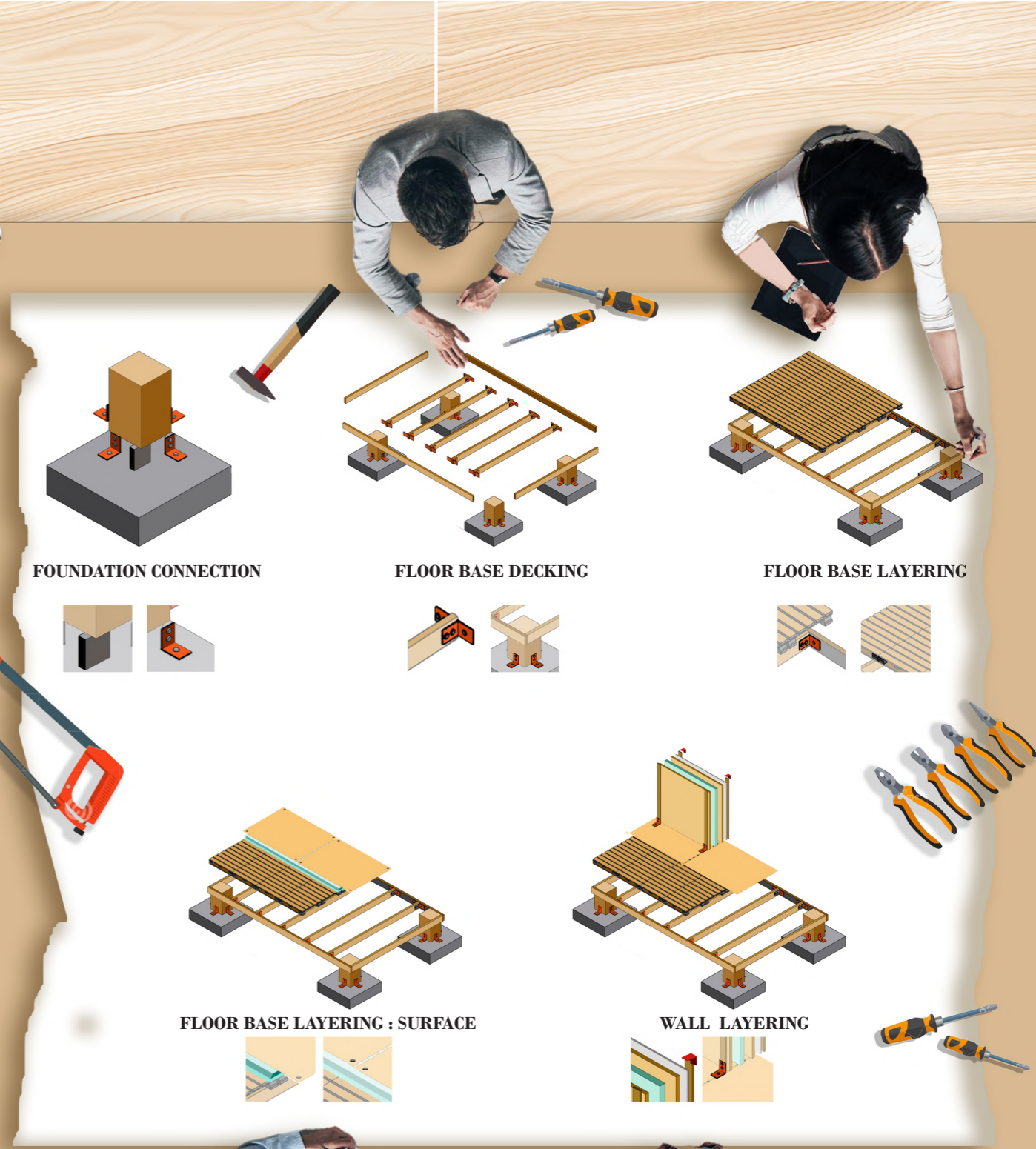

FOUNDATION CONNECTION

FLOOR BASE DECKING

FLOOR BASE LAYERING

FLOOR BASE LAYERING : SURFACE

WALL LAYERING



MATERIAL PRECEDENT : Oasis Children's Venture

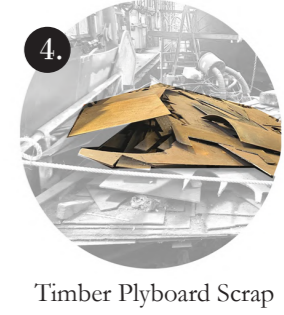
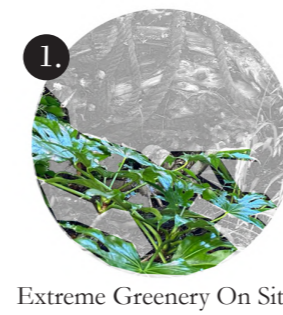
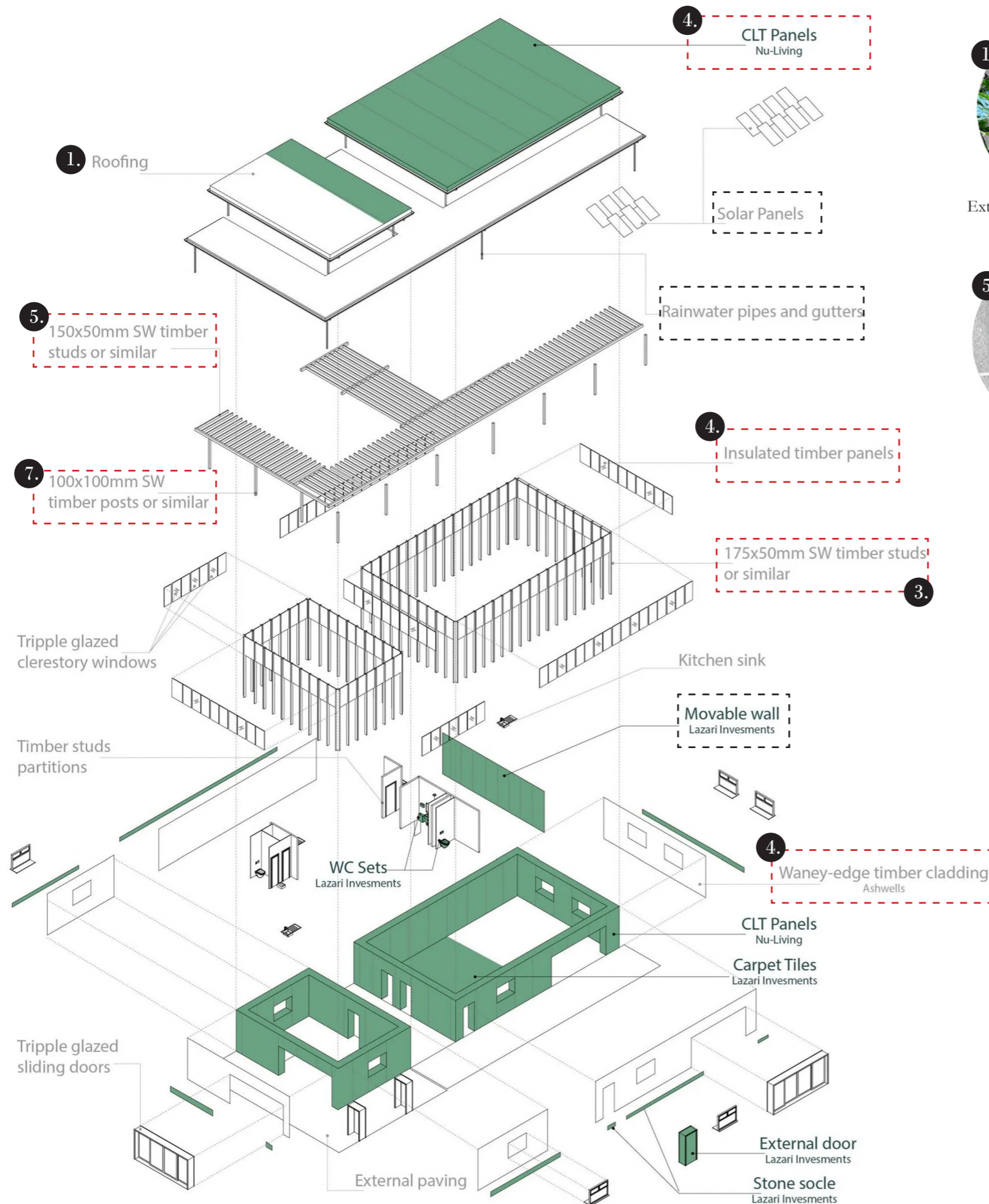

 Elements produced from on Site Materials

 Elements Later utilised in the design

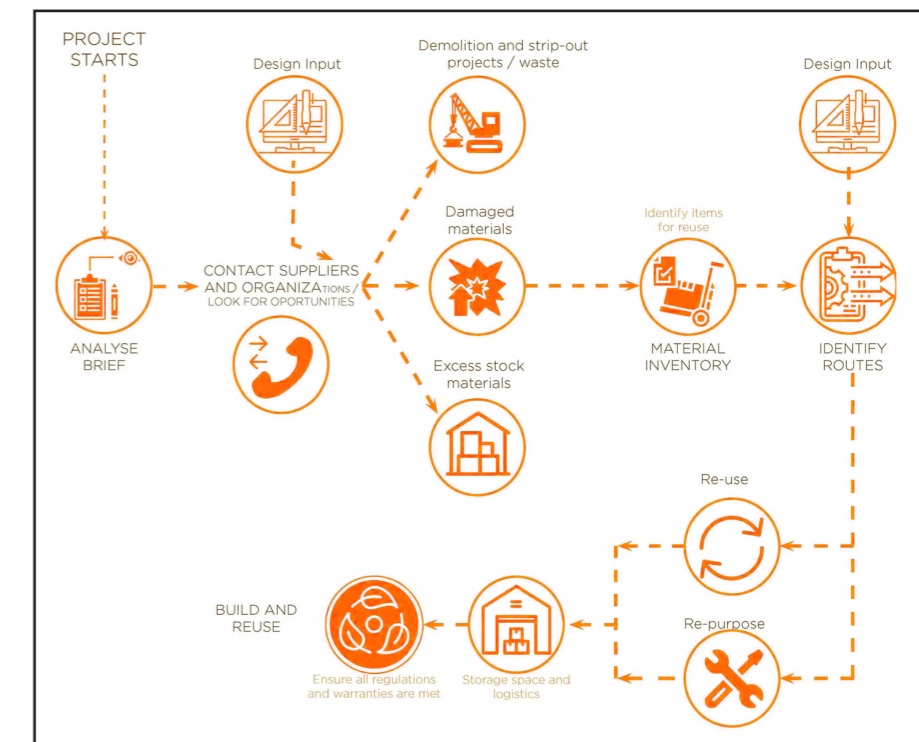

Material Circular Economy

The precedent helps in informing the use of reclaimed timber as a construction material, the precedent is a social kitchen but proposed a structure setting a base inspiration for adequate material use. The precedent analysis highlights the materials found on site that are similar or alternates to the ones used in the precedent project.

CIRCULAR ECONOMY ON SITE : Incorporation of Materials in Proposal



WALL LAYERING

FLOORING LAYERING



- ← Live load on the pallets from community movement
- ← Load distribution in the timber pallets
- ← Load transfer from timber pallet base to the rubble base
- ← Irregular load distribution to existing site rubble

PROJECT : PALLET HOUSE

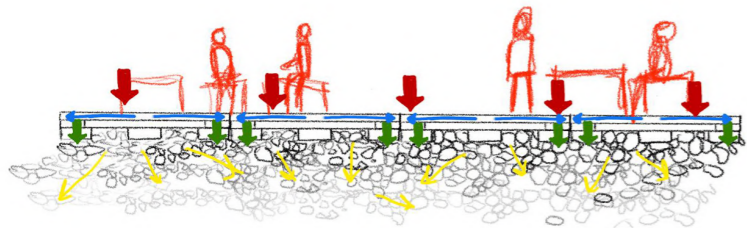

PRECEDENT 2 : UNDERSTANDING THE FLIXIBLE USE OF RECLAIMED PALLETS IN A SMALL SCALE PROJECT

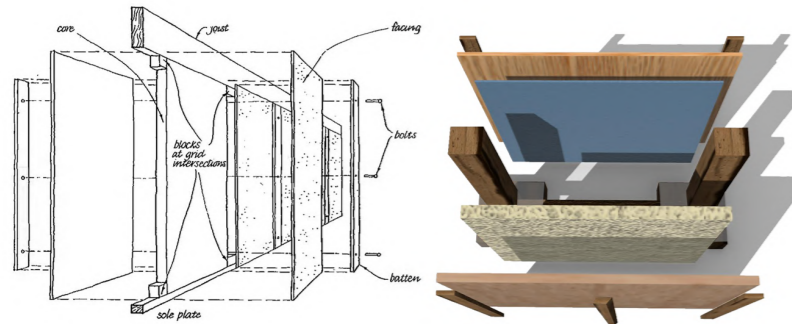

PROJECT : WALTERS WAY

PRECEDENT 3 : TIMBER WALL LAYERING PRECEDENT

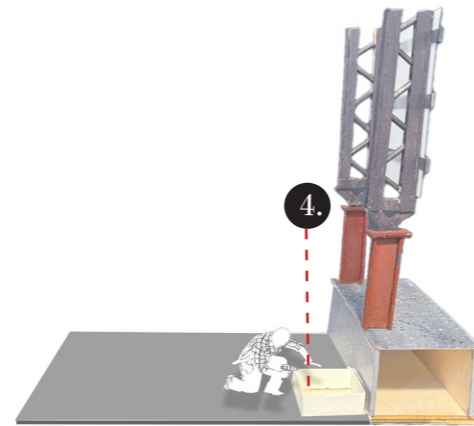

STEP 1: Setting a mould to set up a foundation, a set space to fill in concrete to hold the stilts to even the incline preent on site. The temporary moulds create a uniform dimension for the foundations.

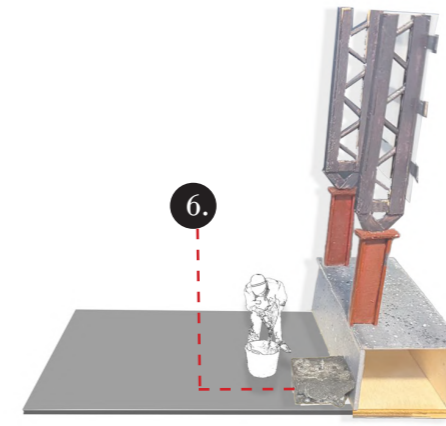

STEP 2: Pouring in the concrete into the mould, fixing with retaining bolts to reduce the effect of water. The concrete holds a metal bracket that acts as a fixture for the timber hardwood stilt column.

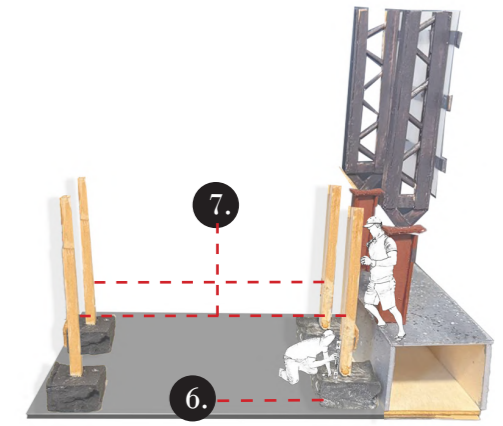

STEP 3: Setting up the columns to hold the flooring base decking and roof decking that hold the flooring. The columns help in holding the wall layers for extra structural stability.

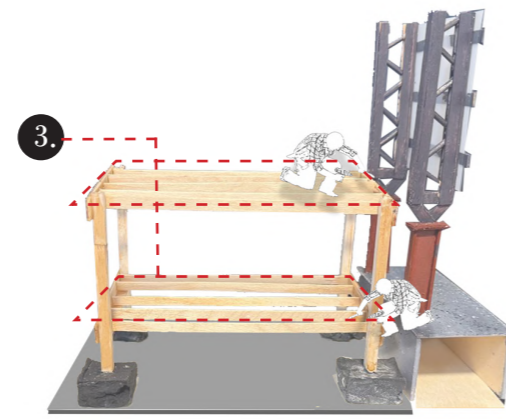

STEP 4: Setting the timber base with timber battens to create a base layer to hold timber pallets for an extra layer to the roof and flooring providing extra stability.

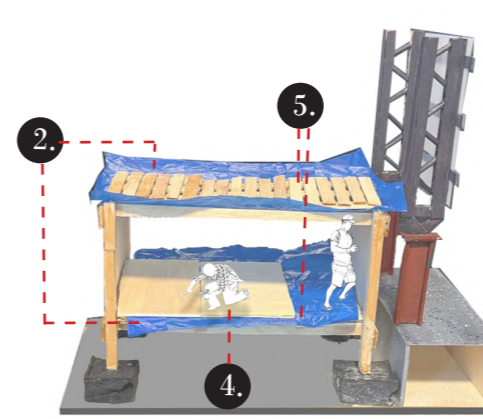

STEP 5: Fixing the flooring and roof layering, with base decking, timber pallets, an anti water insulating layer topped with timber boards for a smooth finish. Making a semi permeable flooring and roof for a good cooling strategy.

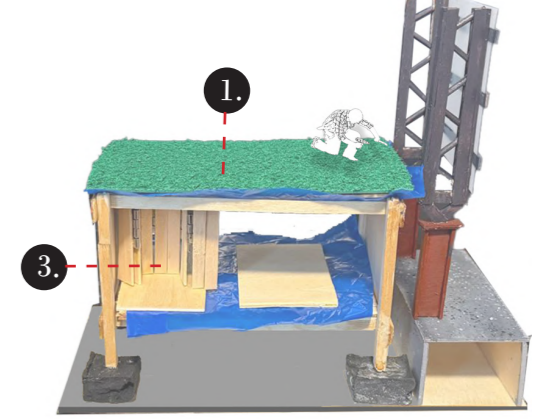

STEP 6: Adding the final toughes of a roof garden and a moveable remote foldable wall that expands and compresses as per use and function of the prposed space.

MONTESSORI SCHOOL DELFT: *Incremental addition for required light and ventilation*

PROJECT : Montessori school Delft
YEAR : 1960-1966
ARCHITECT : Henry Hertzberg

SUNPATH FOR STRUCTURE

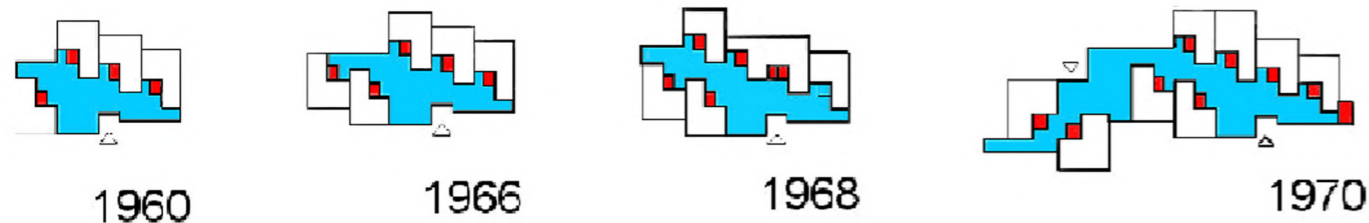
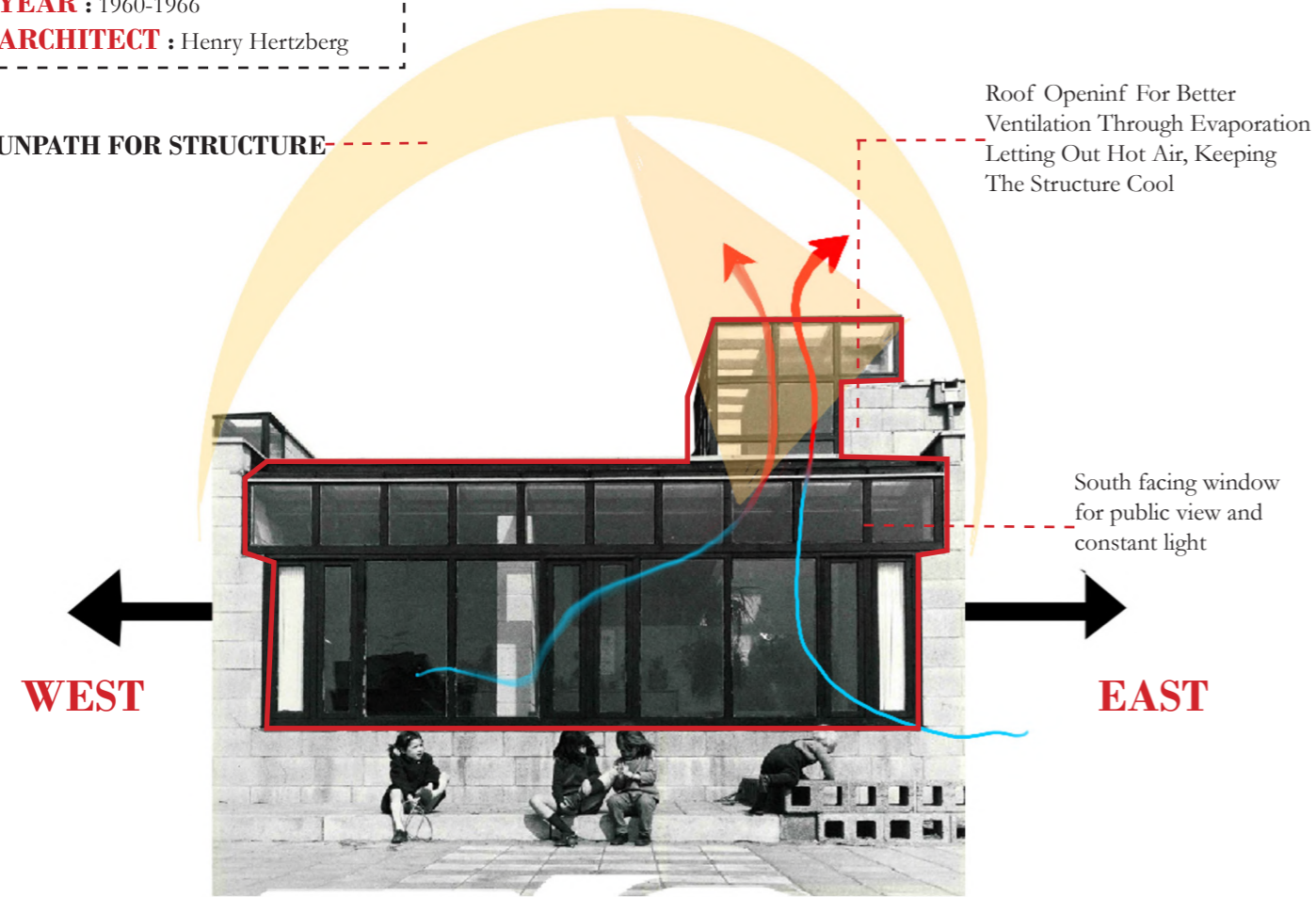

THE INCREMENTAL FEATURE OF THE STRUCTURE THAT FOLLOWS A ROOF EXTENTION PATTERN

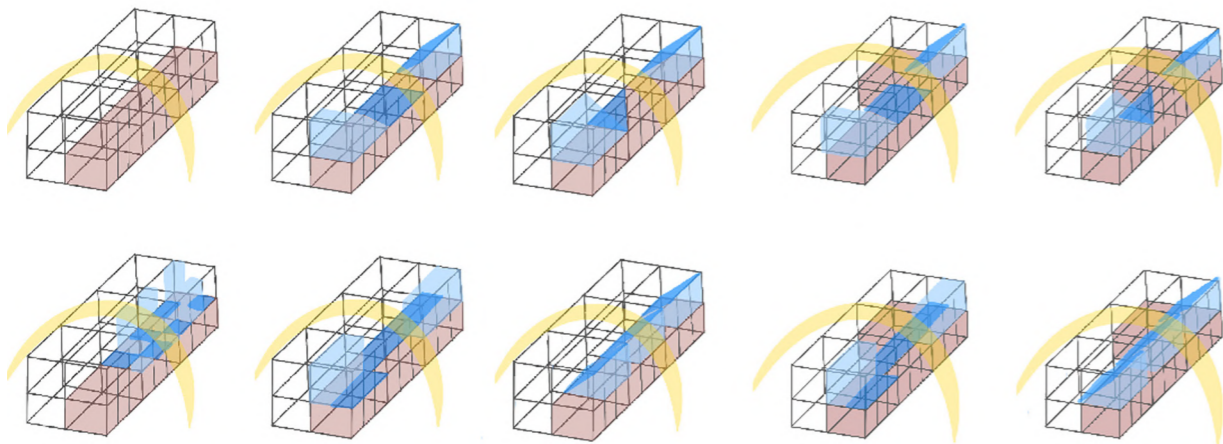

VARIANT ITERATION TO INCULCATE SIMILAR ROOF EXTENTIONS AND LEVEL DIFFERENCES IN THE PROPOSED STRUCTURE

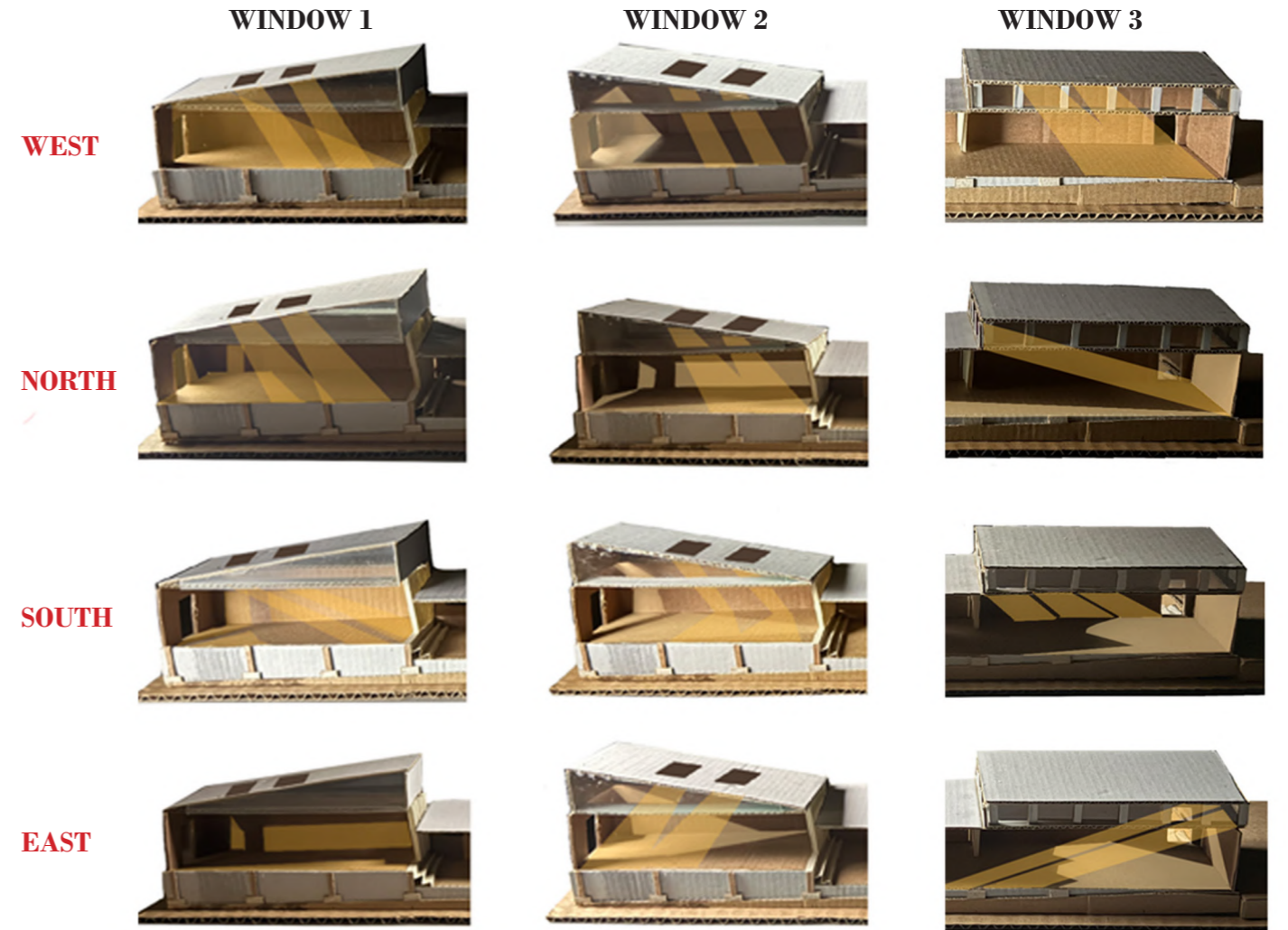

SOUTH FACING SLOPES, EAST AND WEST FACING WINDOWS WITH OPTIONAL OPENINGS PROVIDE ENOUGH NATURAL LIGHT AND BETTER VENTILATION

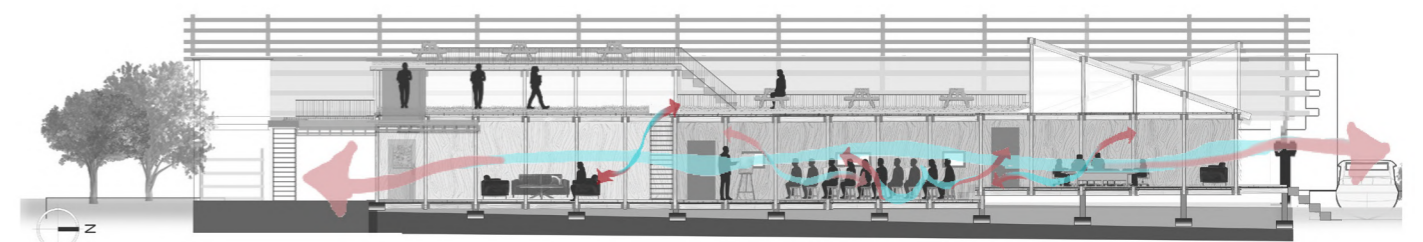
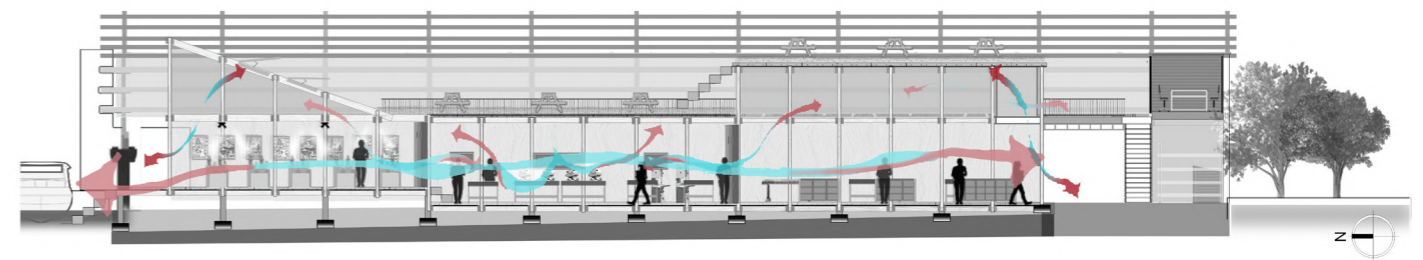

ROOF TYPE ITERATIONS AND ITS CONSTRUCTION LAYERS PRODUCED VIA THE LIGHT STUDY CONDUCTED ABOVE

INCREMENTAL CONSTRUCTION : *Incremental Construction Purpose and Phasing*

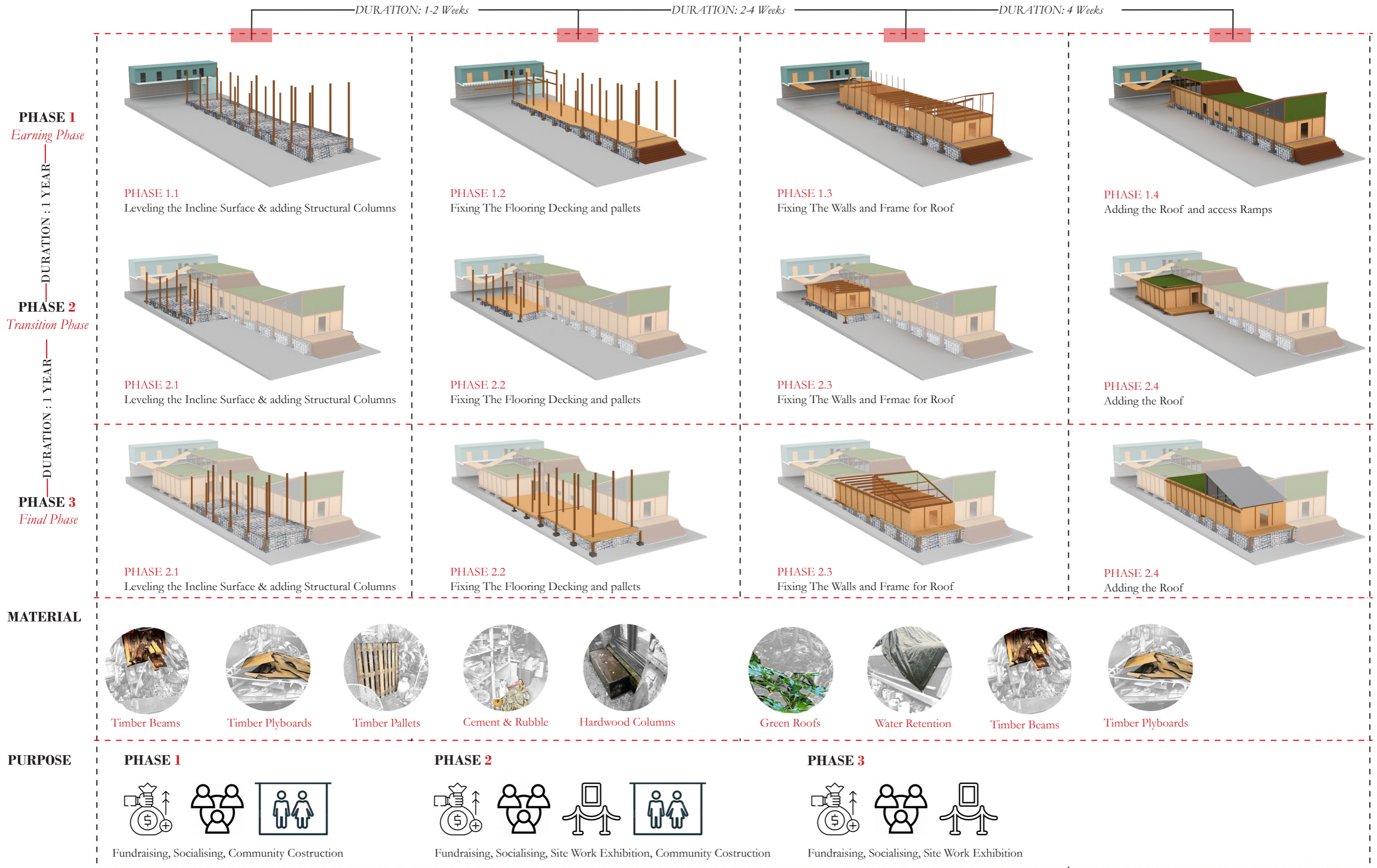

INCREMENTAL CONSTRUCTION : *Function Phasing And Users*

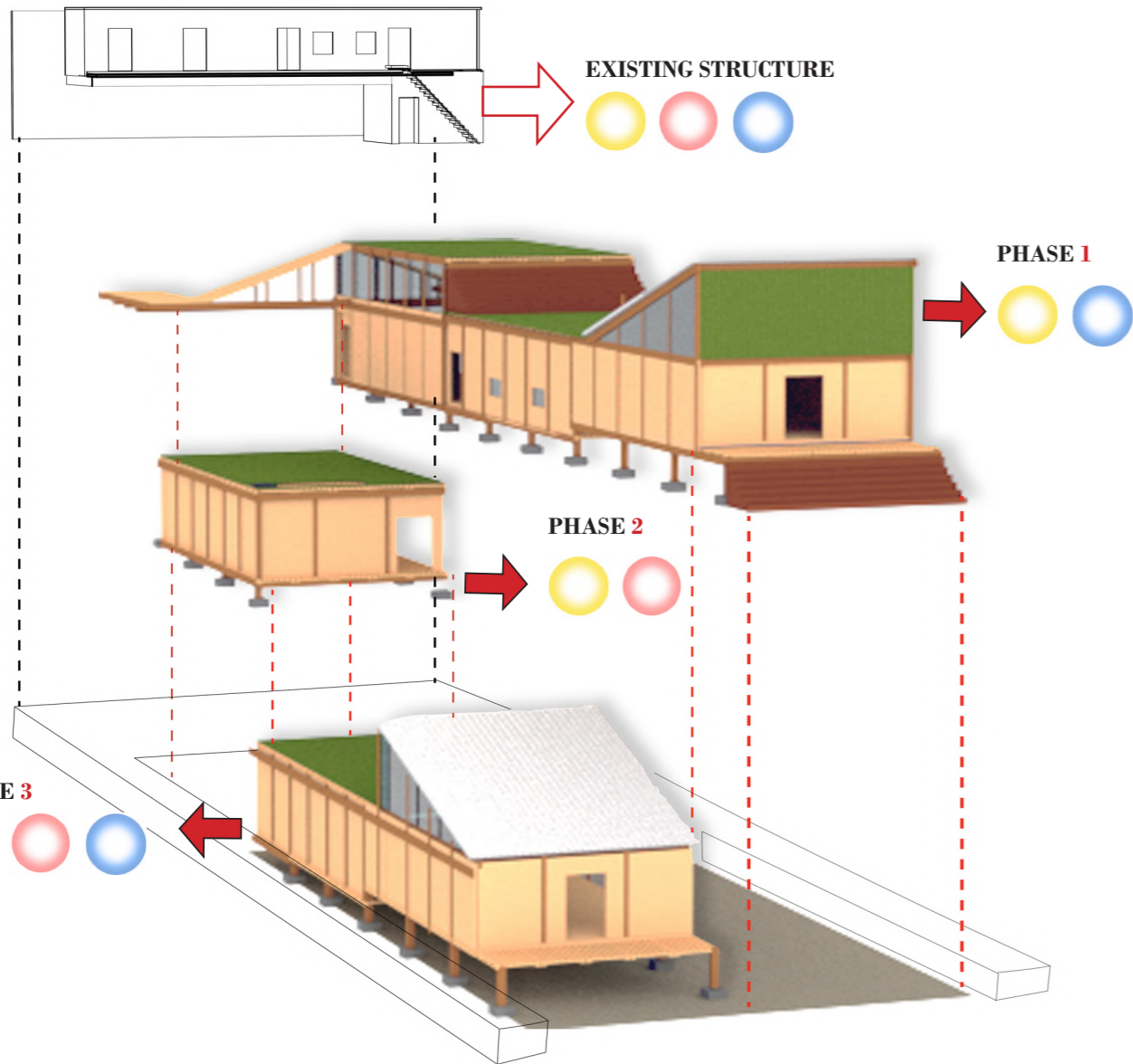
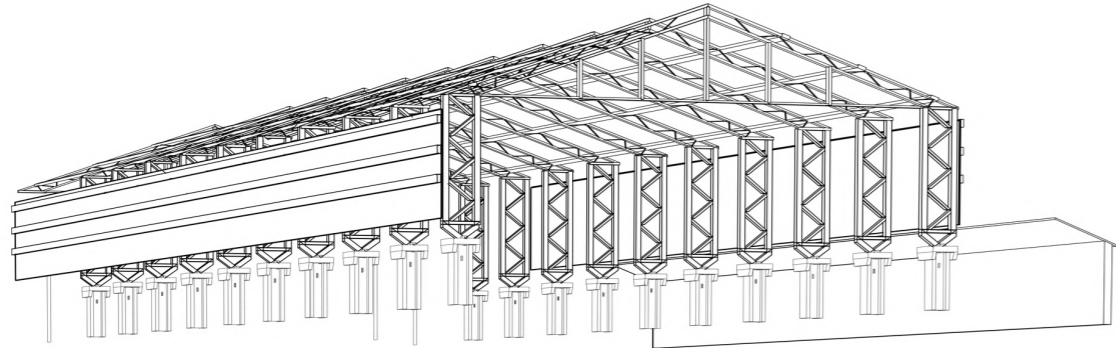

PHASE 3

THE PHASING MASSING CONCEPT FOR THE PREVIOUSLY PROPOSED IDEA TO AID COHERENCE OF DESIGN

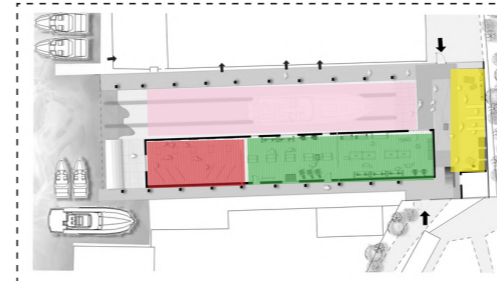
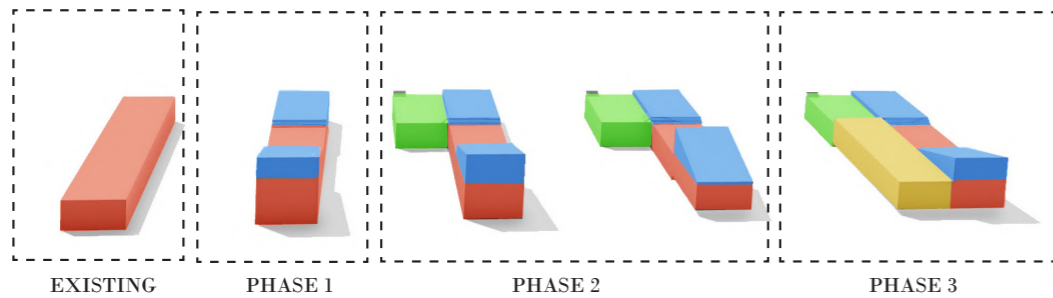

GROUND PLAN : PHASE 1

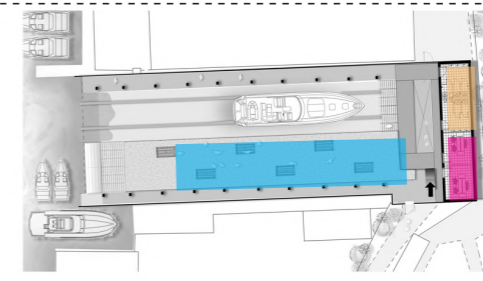

ROOF PLAN : PHASE 1

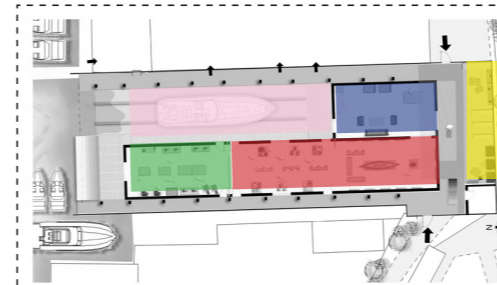
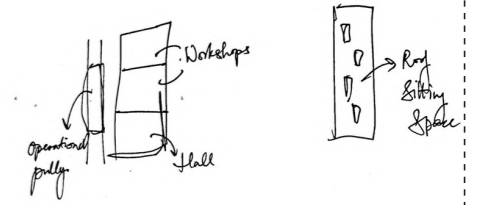

GROUND PLAN : PHASE 2

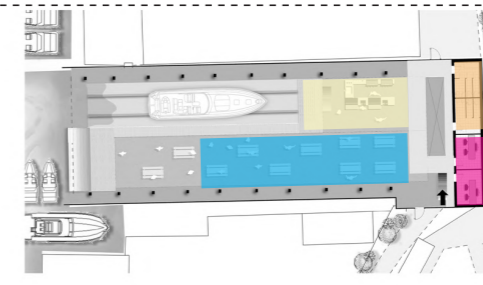

ROOF PLAN : PHASE 2

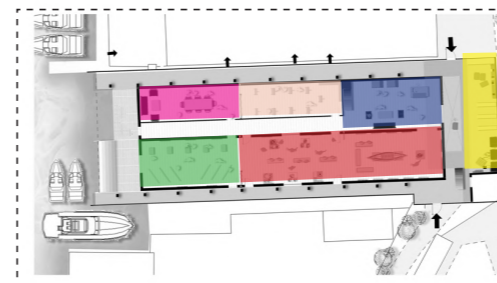
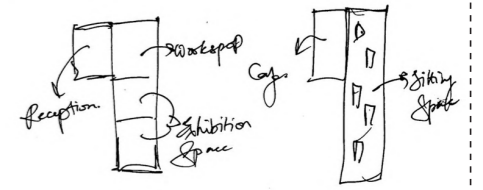

GROUND PLAN : PHASE 3



ROOF PLAN : PHASE 3

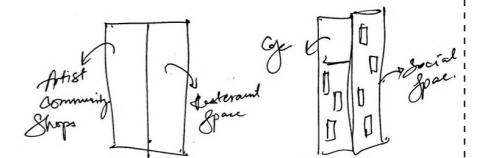

- | | |
|---|---|
| PRESERVED BOATYARD | SITE MANAGEMENT/ RECEPTION |
| SITE WORKSHOPS FOR SITE CONSTRUCTION | SITE REFRESHMENTS ZONE / CAFES AND FOOD STALLS |
| ARTIST DISPLAY SPACES | SITE TEACHING ZONES/ ART CLASS SPACE |
| SOCIAL SPACES/ BREAKOUT SPACES | SITE MAINTAINANCE SPACE/ MATERIAL MANAGEMENT |
| SITE WASHROOMS | OFFICE SPACES/ MEETING SPACES |

The function phasing on site assists the incremental growth of both site constructions and community integration, growing from the assistance of preserved site elements.

The color annotation showcased marks the growth of spaces compared from phase 1 to phase 3, showcasing the structure growth on site and creating space to entertain all communities on site, merging it into a hub based on common functions, tying together the communities on site.

EXISTING SITE: *The Incremental Construction Concept Evolution*

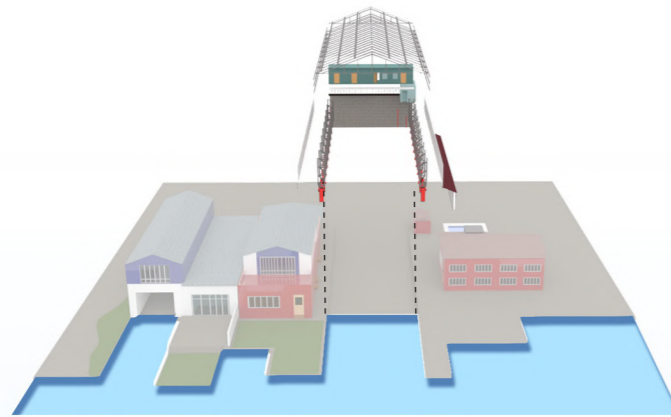

STEP 1:
The existing Site of the Boatyards, with a sloped roof for boat repairs with opposite pathways for access.

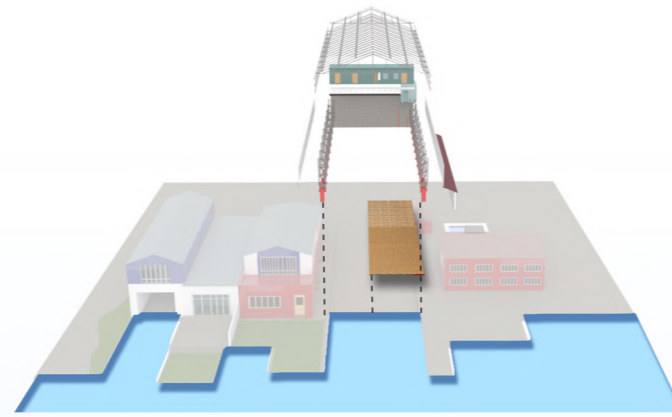

STEP 2:
The existing Site begins with semi leveling of slope to inculcate the structure incrementally on site.

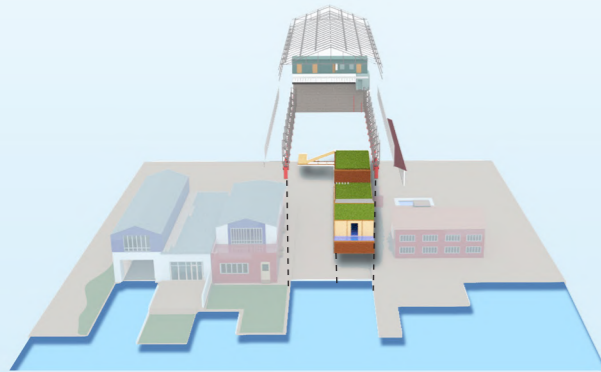

STEP 3:
The construction begins on the side of the boatyards that is opposite the mainly used art studio entries.



STEP 4:
The construction slowly takes over the site incrementally with slow increase of coommunity.

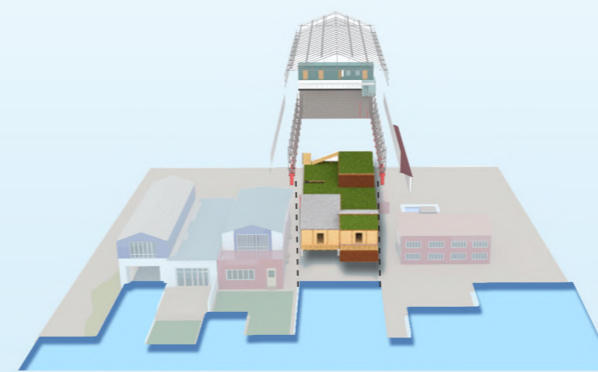

STEP 5:
The slow construction takes into perspective the materiad and human houe aid to carry out self-building.

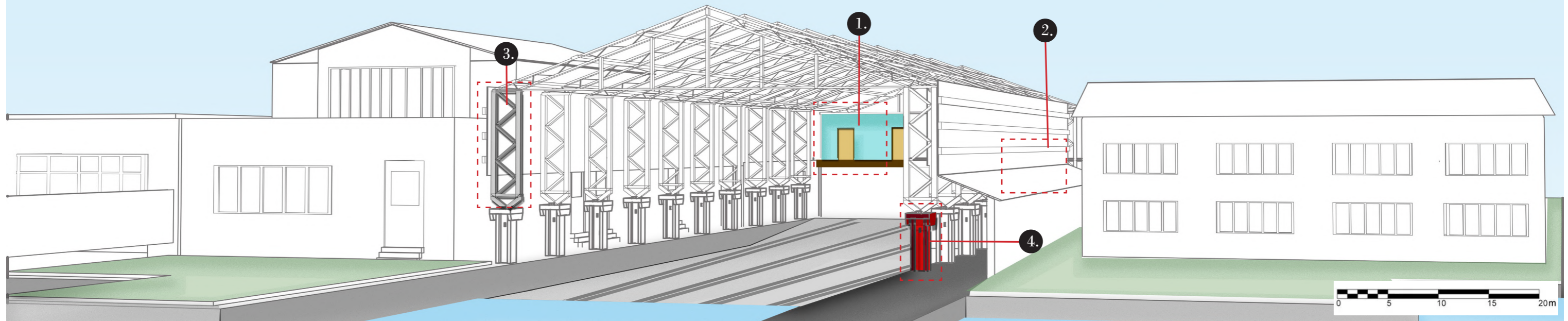
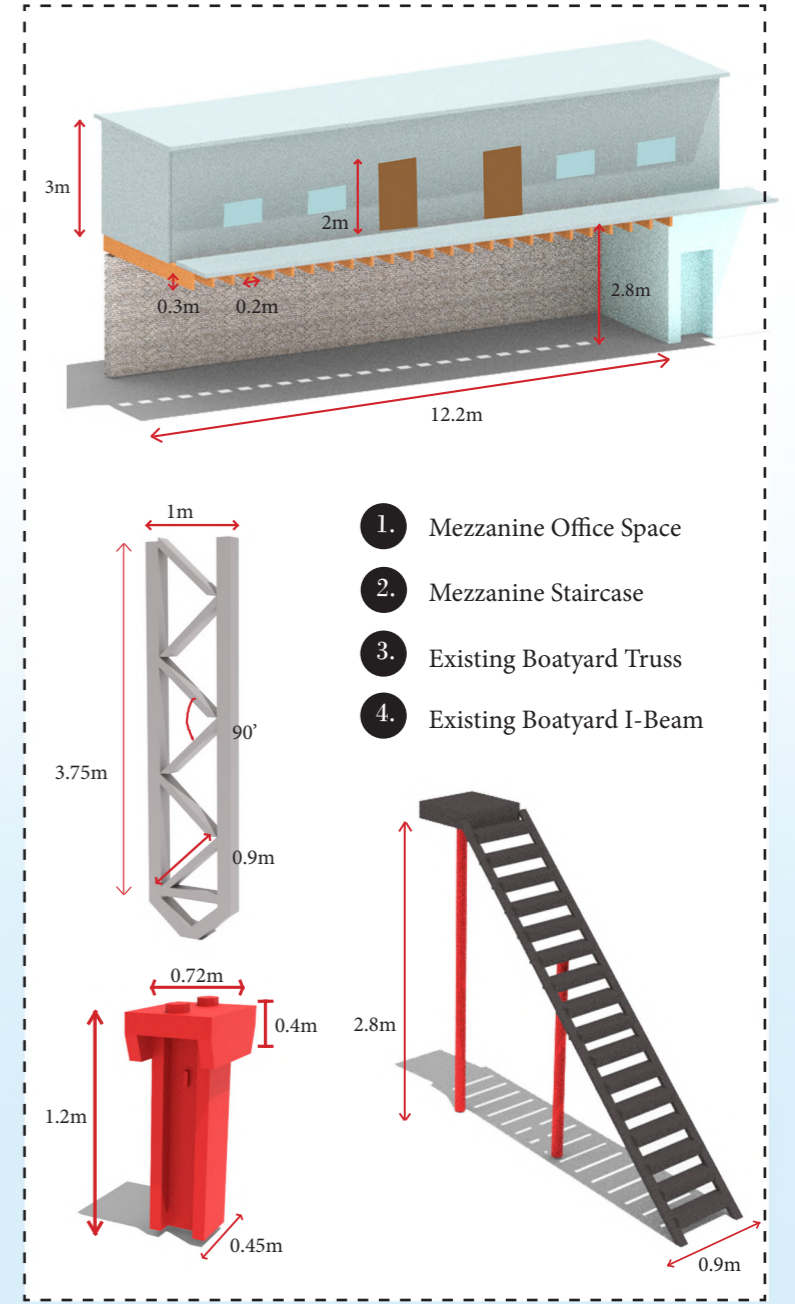

FLOOR PLAN PHASE 1 - 1:100

- 1. Staircase Access to Roof
- 2. Entrance 1
- 3. Wooden Workshop
- 4. Metal Workshop
- 5. Exhibition Room 1
- 6. Entrance from Waterside
- 7. Preserved Boat Pulley
- 8. Walkway towards Artist Studios
- 9. Temporary truss for Boatwork
- 10. Entrance 2
- 11. Material Collection/Sorting And Tool Space
- 12. Washroom 1
- 13. Washroom 2
- 14. Office 1
- 15. Office 2
- 16. Roof Rainwater Gutter
- 17. Staircase for roof leveling
- 18. Breakout Spaces/ Socialising space
- 19. Sunroof Windows for Natural lighting and ventilation
- 20. Ramp for Roof Leveling
- 21. Connectivity ramps to joining existing and proposed space.

The colors of the plan represent the difference between existing elements and proposed elements. The existing structures are highlighted with red while the proposed design is showcased with black.

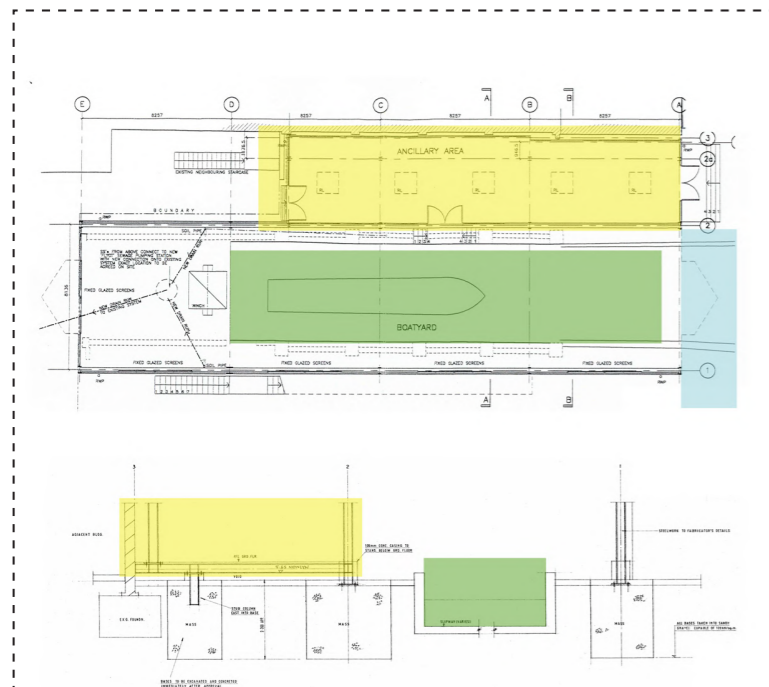
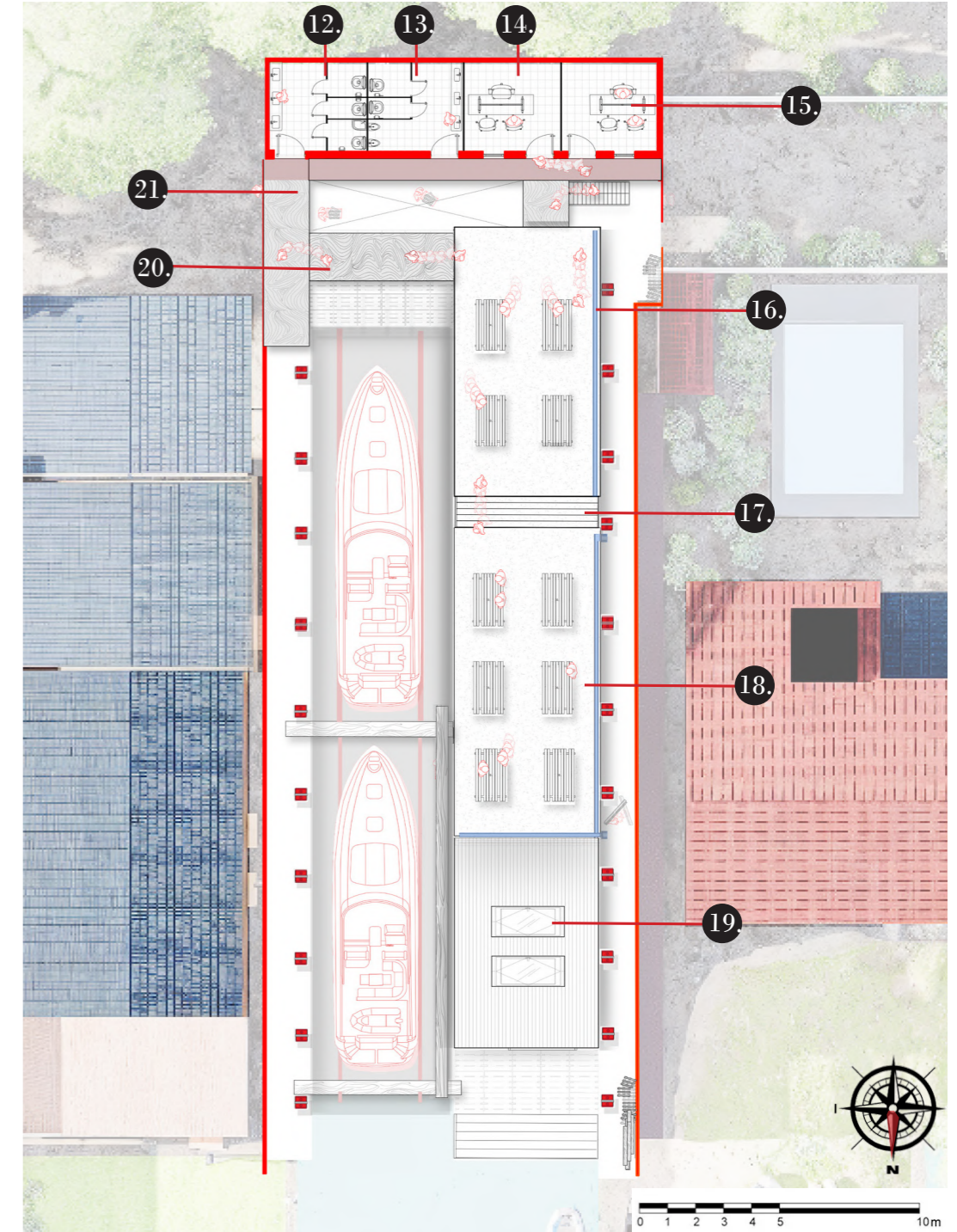
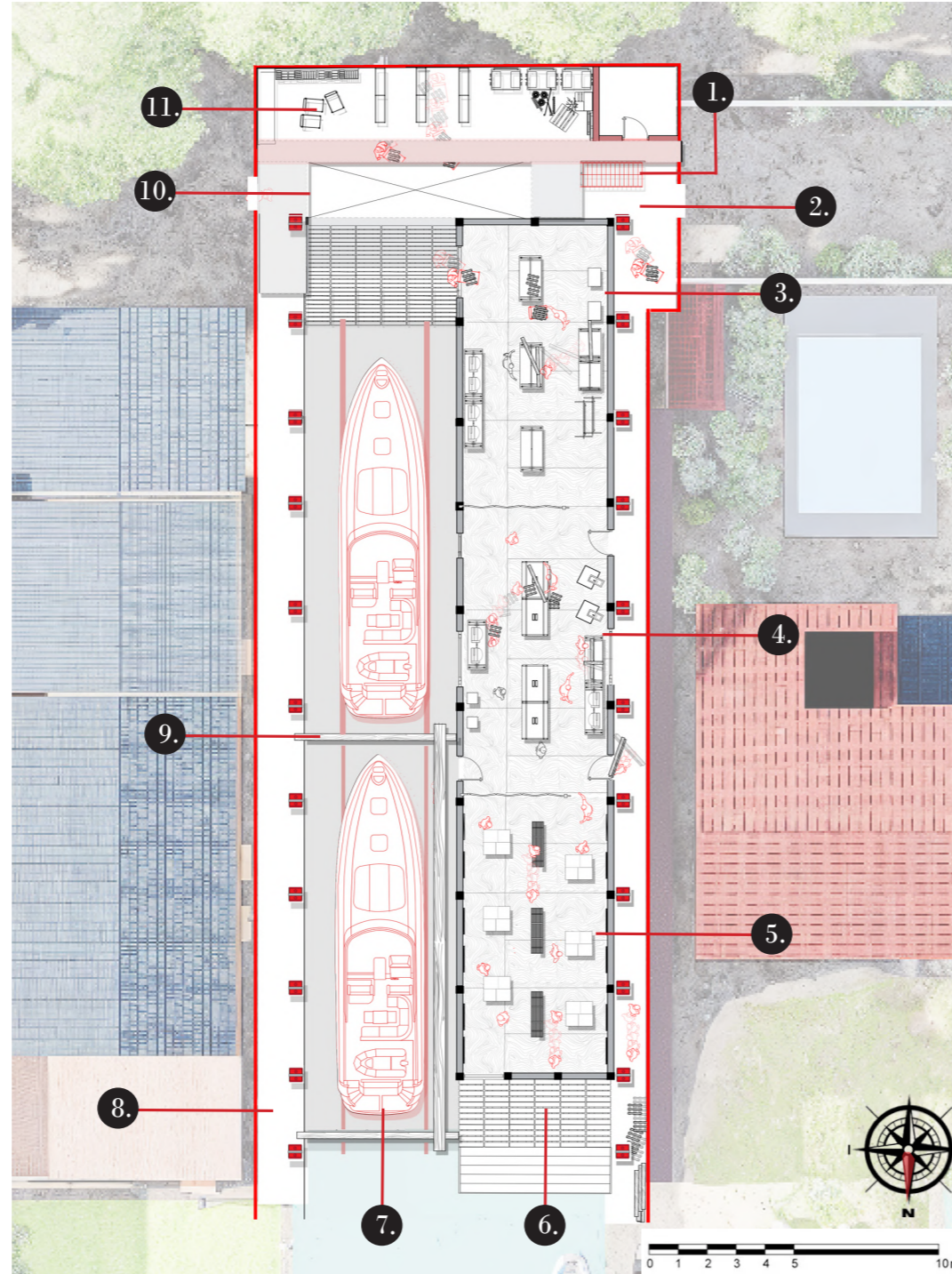

PROJECT : Pheonix Wharf, Eel Pie Island

PURPOSE : Inculcating dual function on site for incremental growth to slowly enhance the site function and community growing from the existing functions.

- Developed Studio spaces
- Preserved Boat Pulley



WIDE BEAM NARROW BOATS
width range between 3.05 to 3.66 meters
length varies and can extend upto 21.34 meters



DUTCH BARGE
width 3-6 meters
length 15-40 meters



TRADITIONAL HOUSE BOAT
width : 2.1 meters
length : 15-22



BROOM BOAT
width varies from 3.2 meters to 4.57 meters
length varies from 9.14 meters to 15.24 meters



SEA MASTER 26
width 2.51 meters
length 7.92 meters

FLOOR PLAN PHASE 2 - 1:100

PROJECT : UAL Workshop
PURPOSE : Flow of furniture and machines in the workshop for ideal work

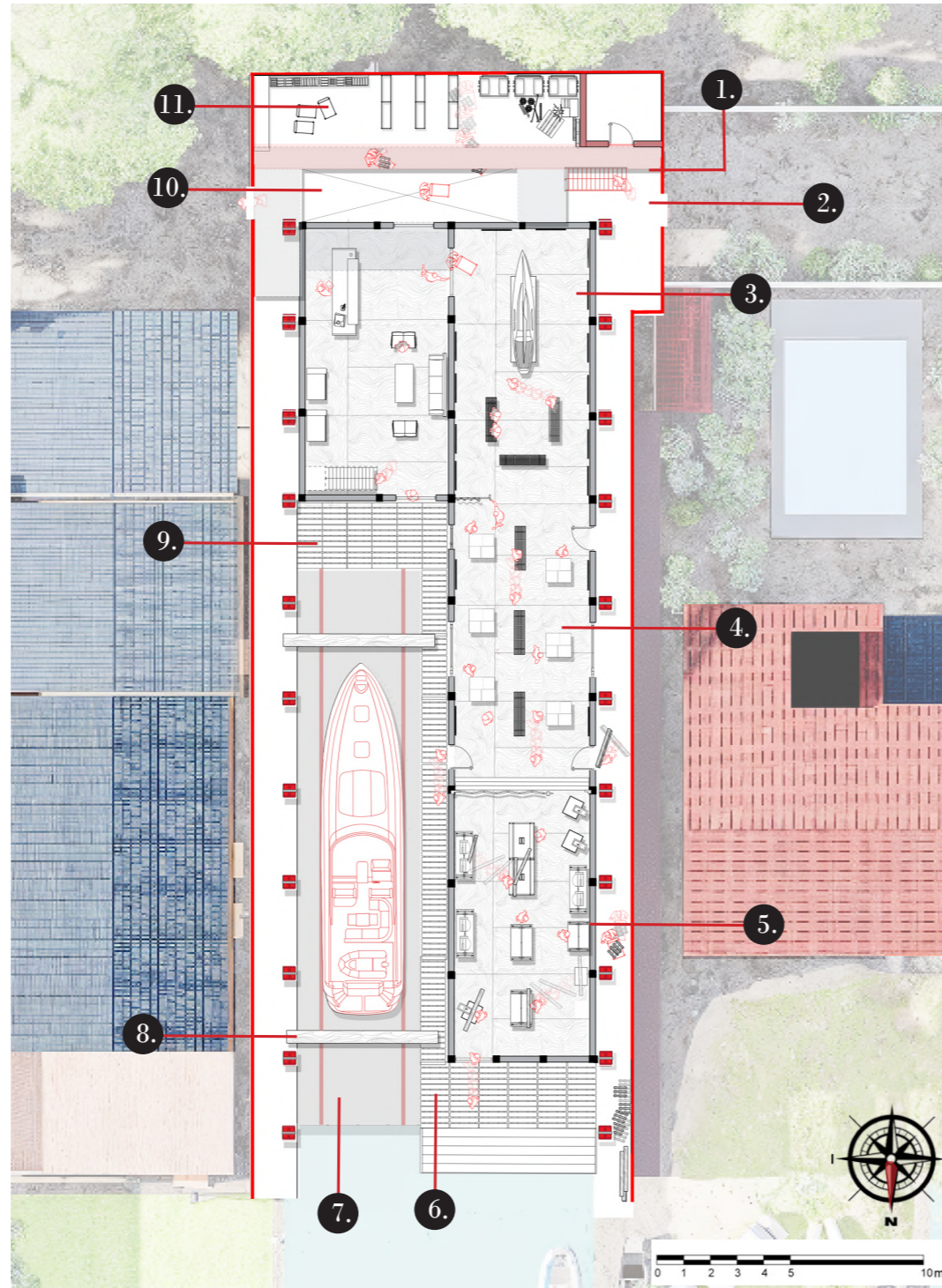
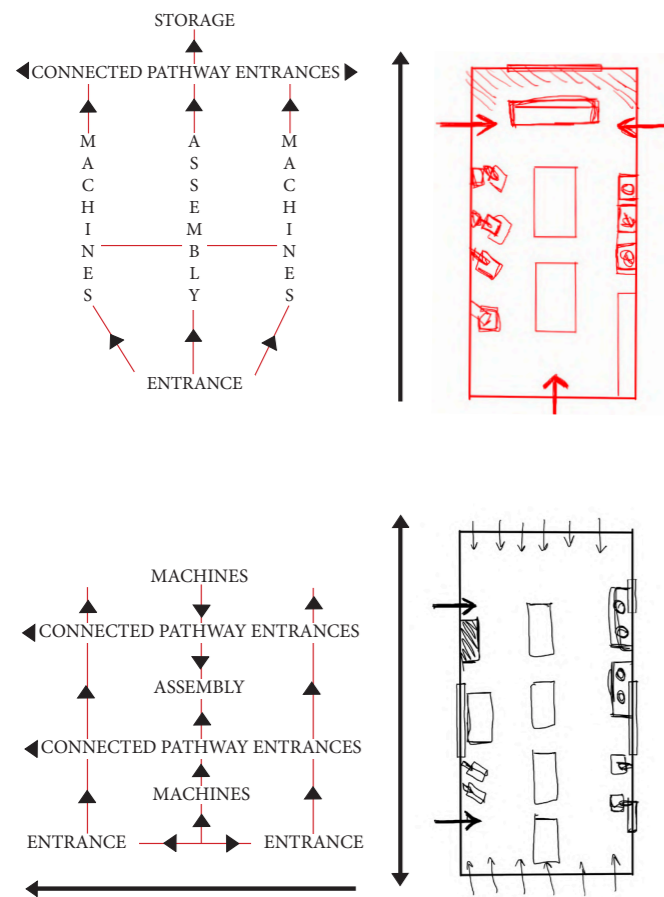
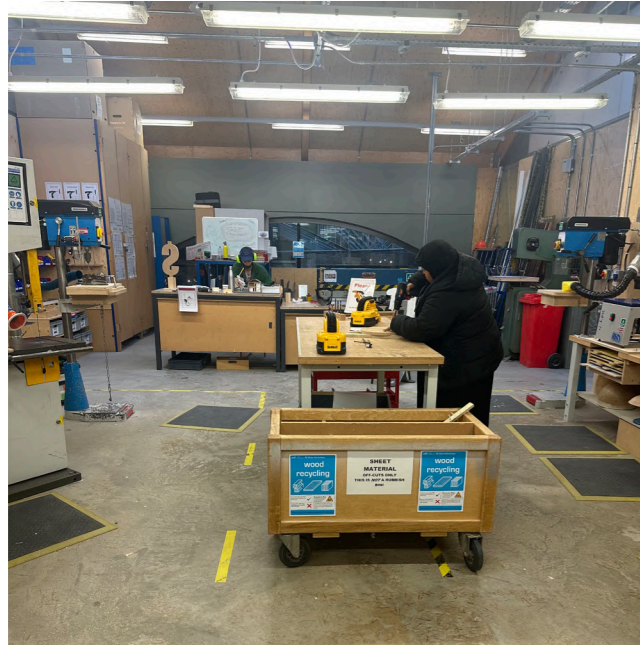

- 1. Staircase Access to Roof
- 2. Entrance 1
- 3. Exhibition Space 1
- 4. Exhibition Space 1
- 5. Mixed Model Space
- 6. Connecting Pathway from exterior

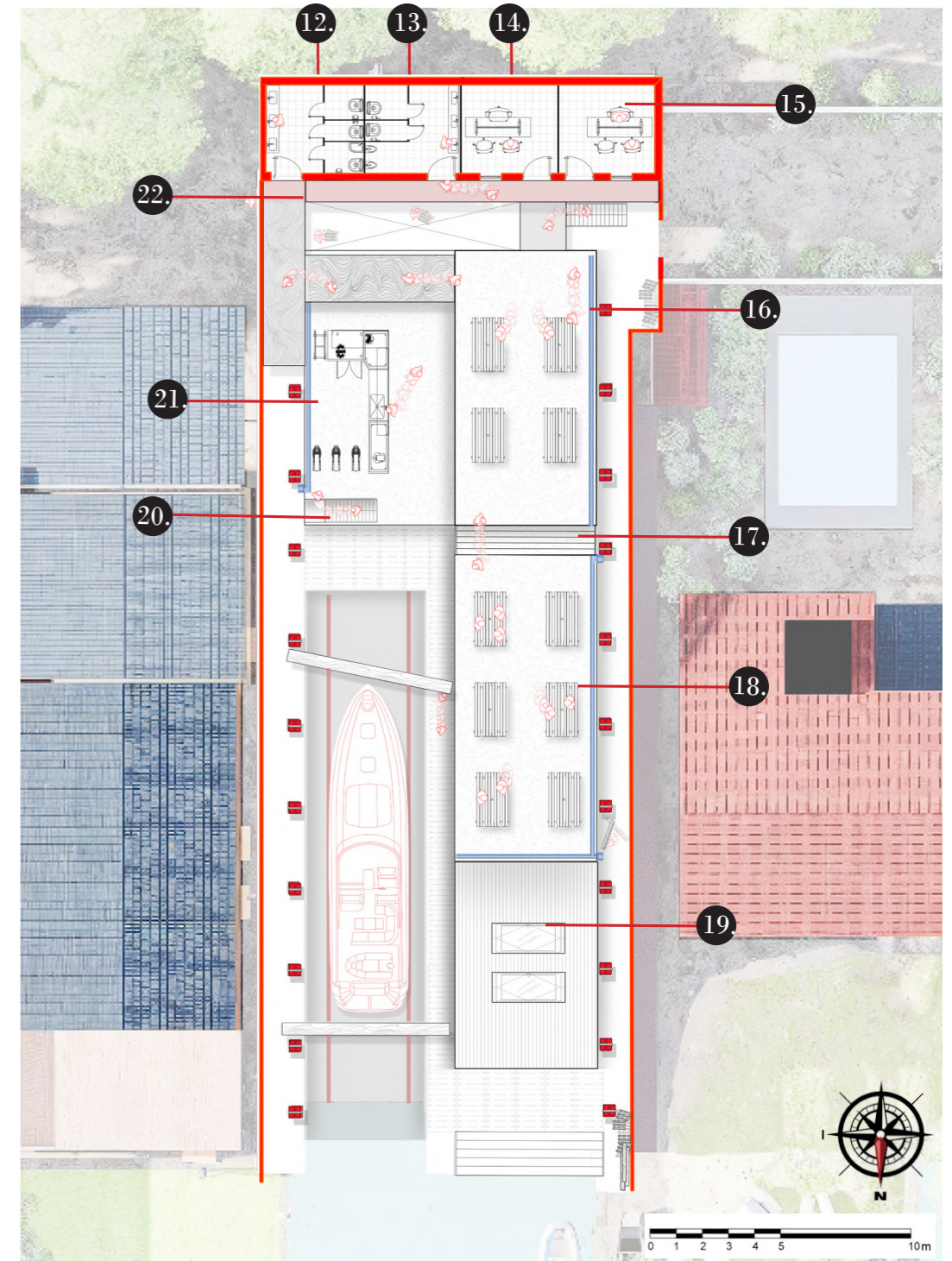

- 7. Semi- Preserved Boat Pulley
- 8. Temporary truss for Boatwork
- 9. Break point between project entrance Pulley
- 10. Entrance 2
- 11. Material Collection/Sorting And Tool Space
- 12. Washroom 1
- 13. Washroom 2
- 14. Office 1
- 15. Office 2
- 16. Roof Rainwater Gutter
- 17. Staircase for roof leveling
- 18. Breakout Spaces/ Socialising space
- 19. Sunroof Windows for Natural lighting and ventilation
- 20. Interior Access to Roof
- 21. Roof Top Cafe
- 22. Ramp connectivity.

FLOOR PLAN PHASE 3 - 1:200

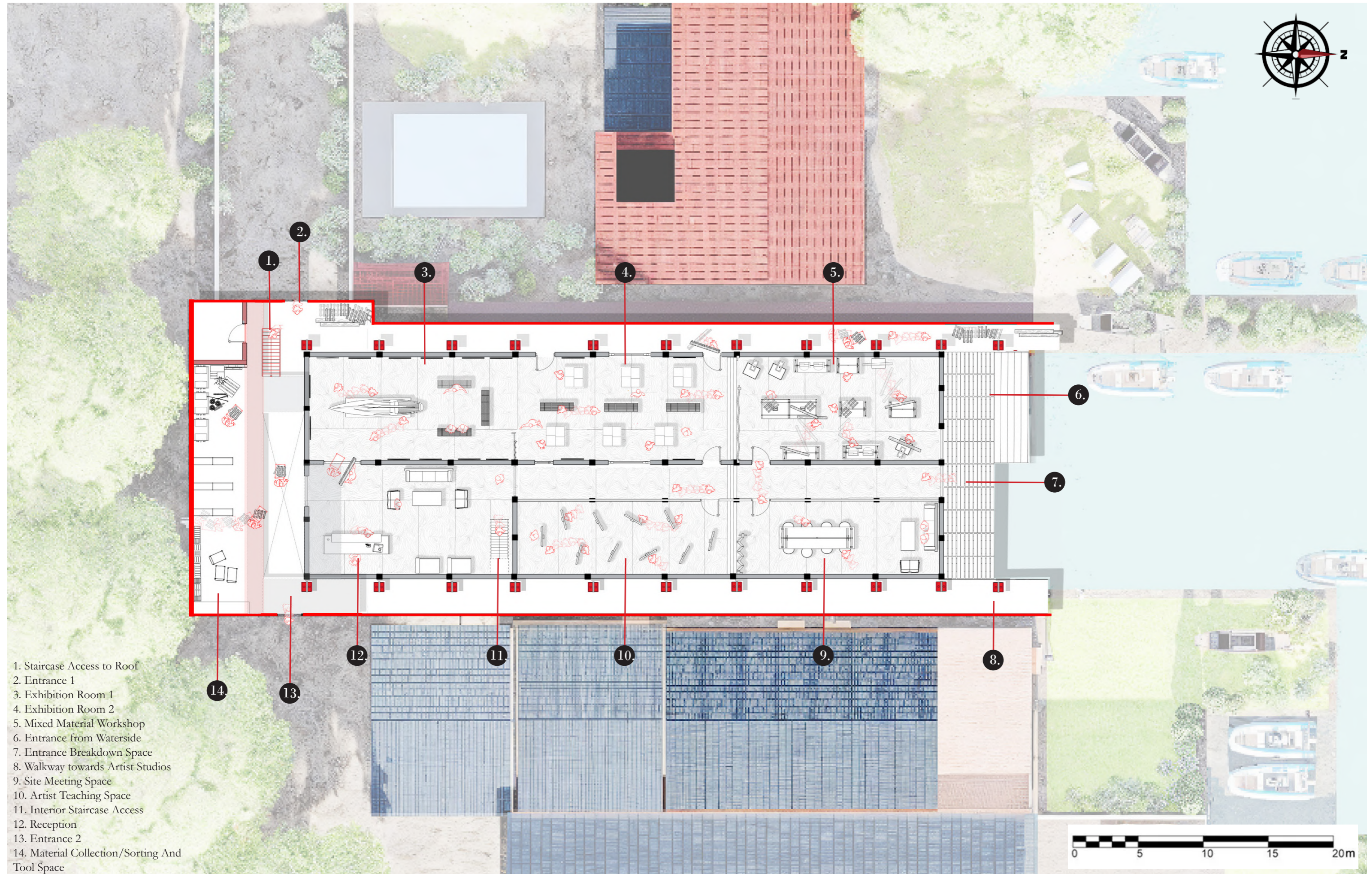

FLOOR PLAN PHASE 3 - 1:200

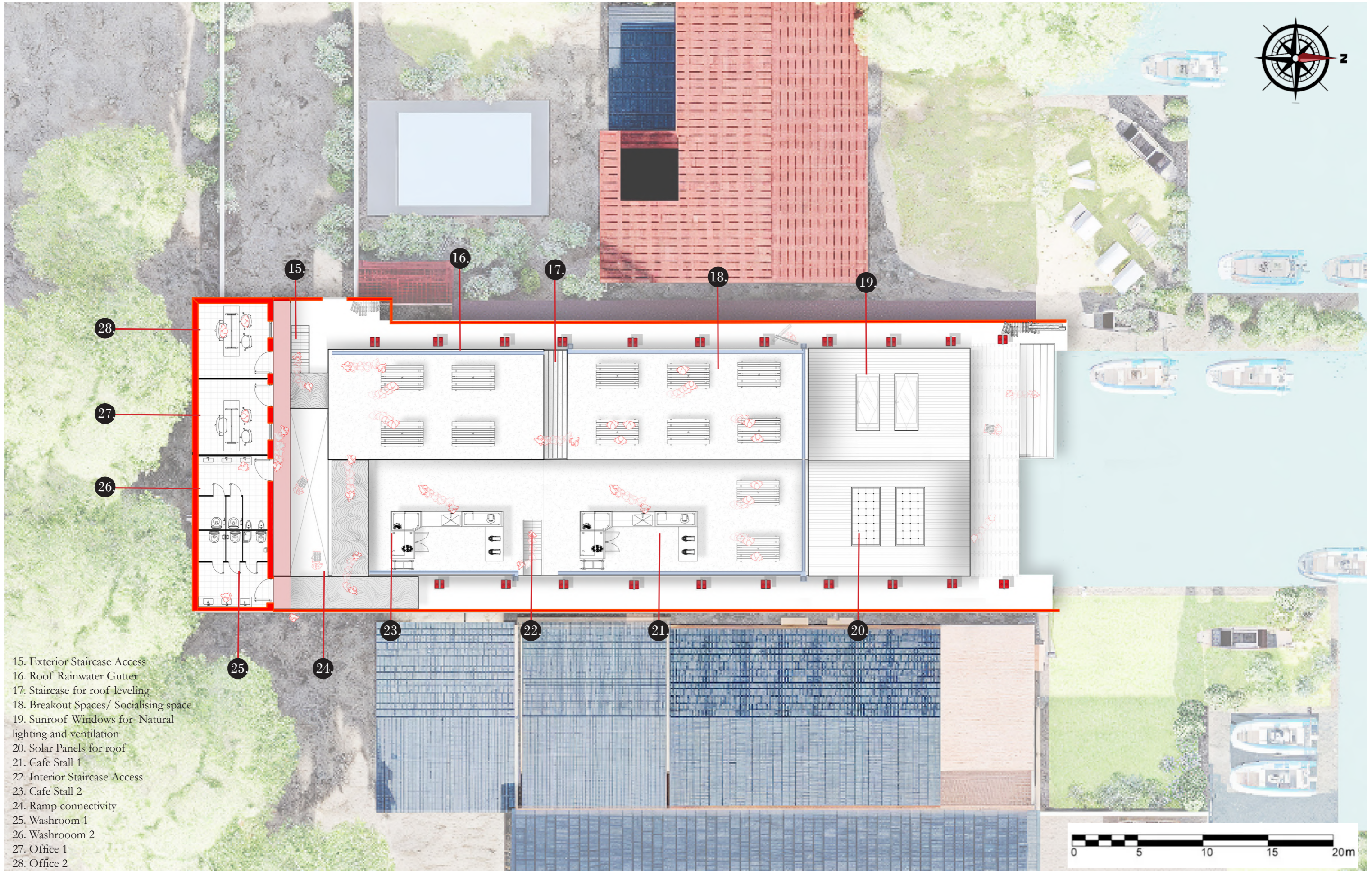

- 15. Exterior Staircase Access
- 16. Roof Rainwater Gutter
- 17. Staircase for roof leveling
- 18. Breakout Spaces/ Socialising space
- 19. Sunroof Windows for Natural lighting and ventilation
- 20. Solar Panels for roof
- 21. Cafe Stall 1
- 22. Interior Staircase Access
- 23. Cafe Stall 2
- 24. Ramp connectivity
- 25. Washroom 1
- 26. Washroom 2
- 27. Office 1
- 28. Office 2

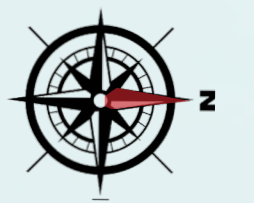
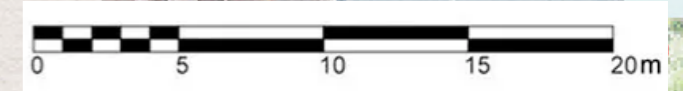

FLOOR PLAN TEXTURES - 1:50

The zoomed in Floor plan of the workshop space from the plans aboveshowcases the material usage and layering. The plan also reflects upon the machines often found in an ideal workshop. The study carried out at the *Campus workshop is the inspiration, annotated in detail in the Design Journal.*

The view showcases the manner in which the people use the site material and machines. Also carried along is the understanding of modular walls to maintain site spatial activity.

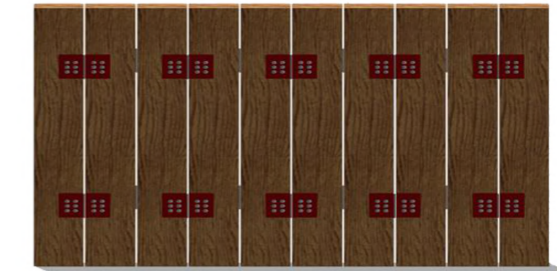
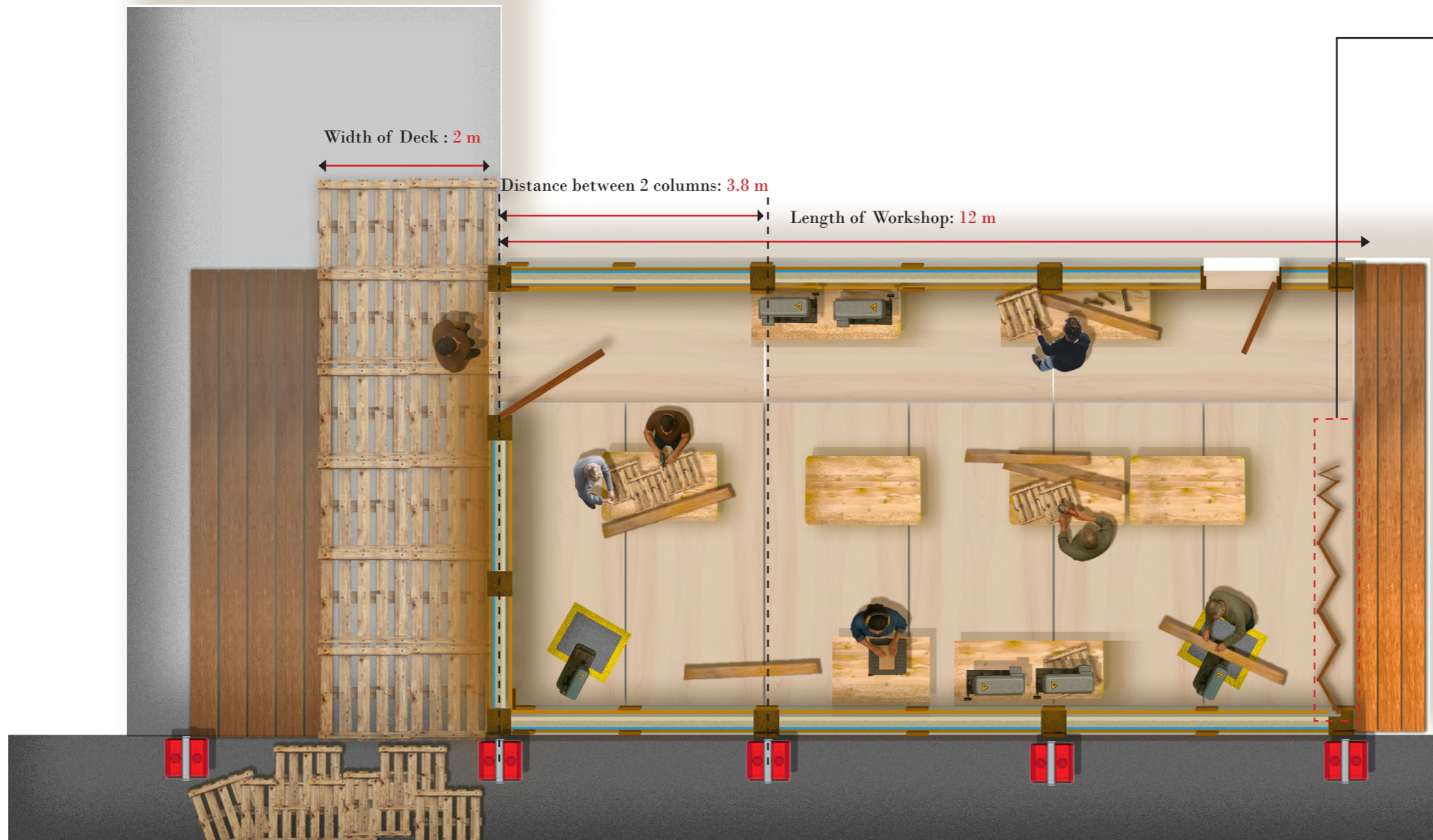

Function of the Modular walls : Bi-fold Panel System



Working of the walls Opening and Closing for spatial management

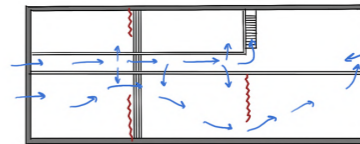

Semi-closed walls

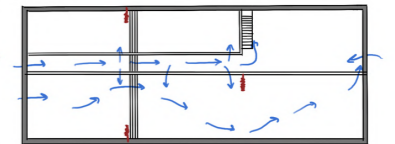

Closed off walls

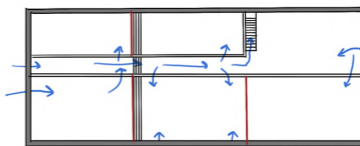

Opened walls

◇ MODULAR WALLS DETAILS

Width of Workshop: 6 m

Width of sidewalk: 1.5 m

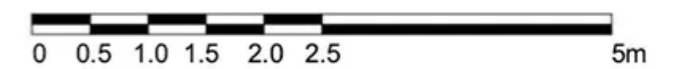

SECTION AND ELEVATION : 1:100 & 1:200

- 1. Artist Studios
- 2. Existing Boatyard Truss
- 3. Residential Structure
- 4. Mezzanine Office
- 5. Roof Cafe
- 6. Interior Roof Access
- 7. Reception Area
- 8. Base Foundations
- 9. Rubble Gabbions
- 10. Artist Exhibition Space
- 11. Rain Water Gutter
- 12. Roof Top socialising space

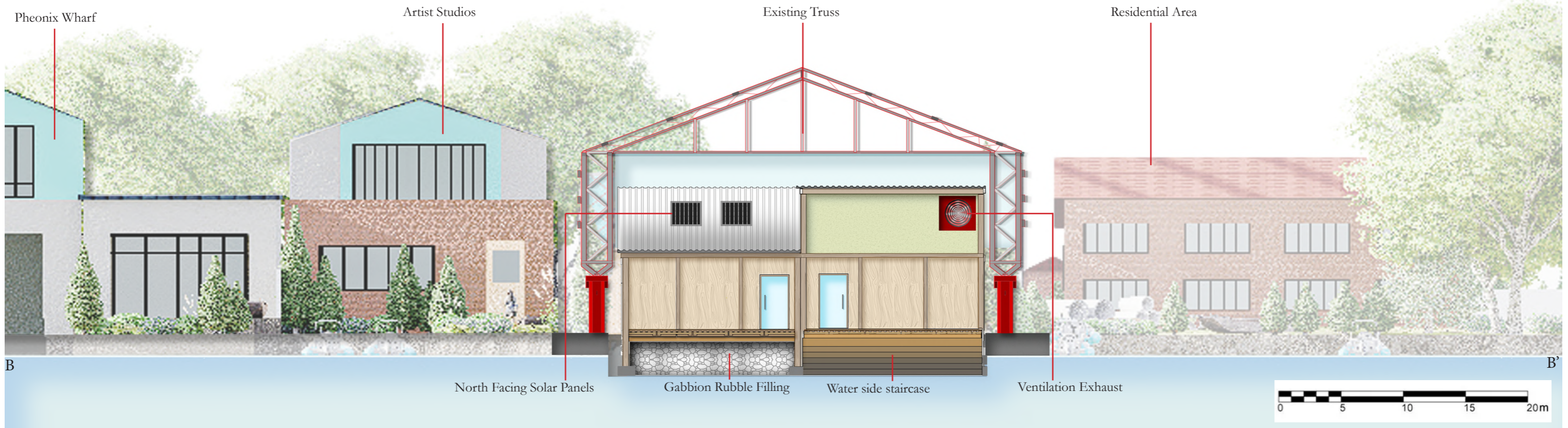
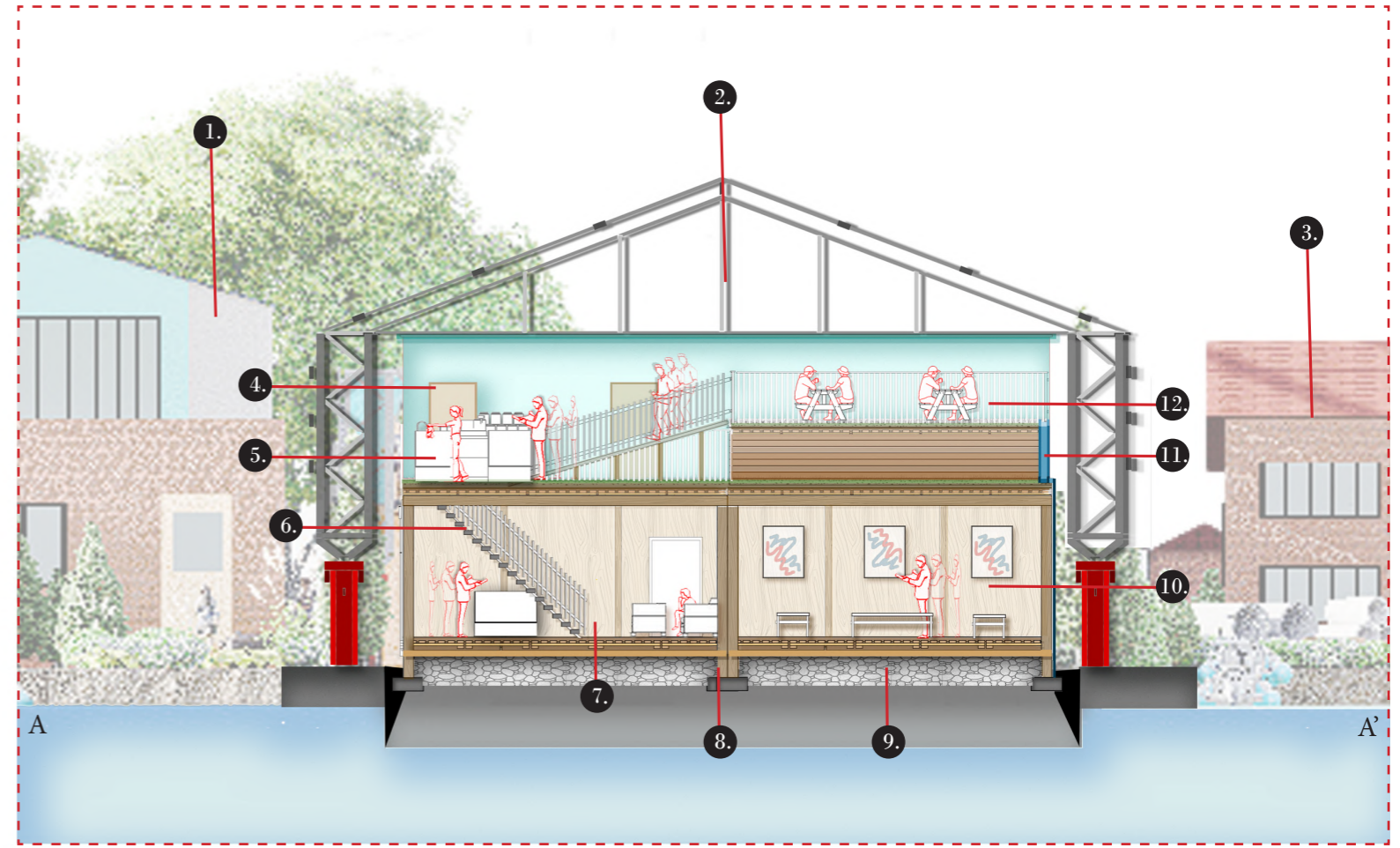
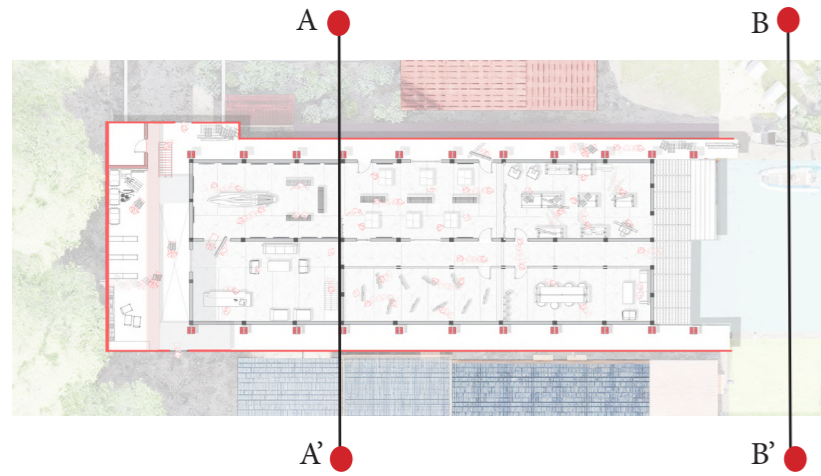

SITE SECTION - 1:200

- 1. Exterior Rooftop Access
- 2. Entrance 1
- 3. Raised Roof windows
- 4. Roof Top Seating
- 5. Roof steps for roof Leveling
- 6. Roof Top Seating
- 7. Mechanical Ventilation Ducts
- 8. South Facing Skylights
- 9. Mixed Workshop
- 10. Rubble Gabbion
- 11. Exhibition Space 1
- 12. Exhibition Space 2
- 13. Material Collection Bins
- 14. Mezzanine Office

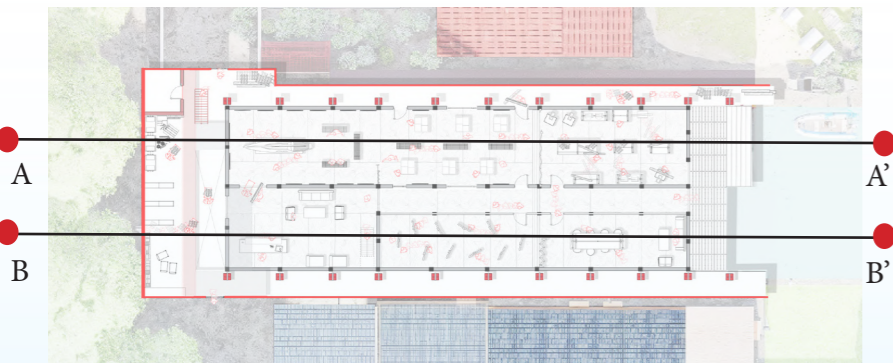

PROJECT : Novotel, Wembley
PURPOSE : Reason for south and north facing windows when light is blocked from east and west

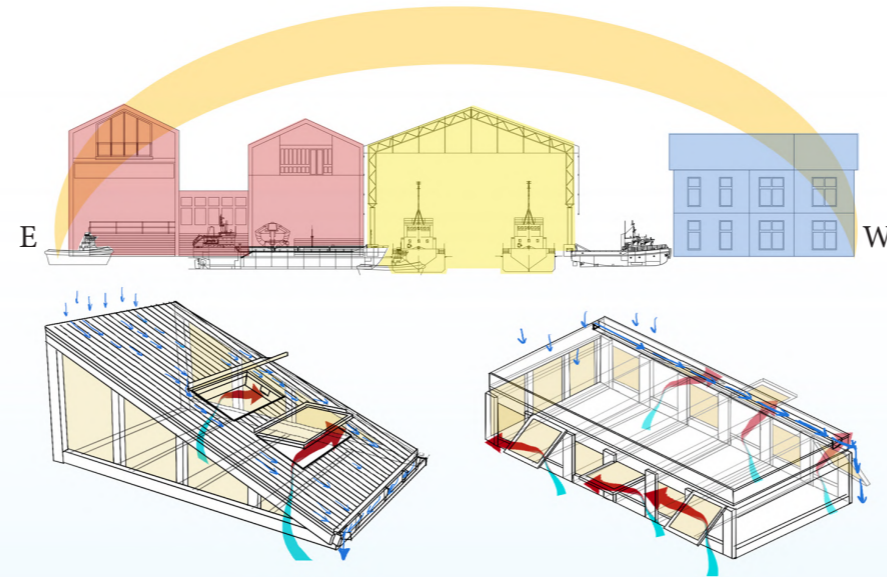

LIGHTING ANALYSIS

PROJECT : Pompidou Center
PURPOSE : Planning of ventilation for workshop appliances.

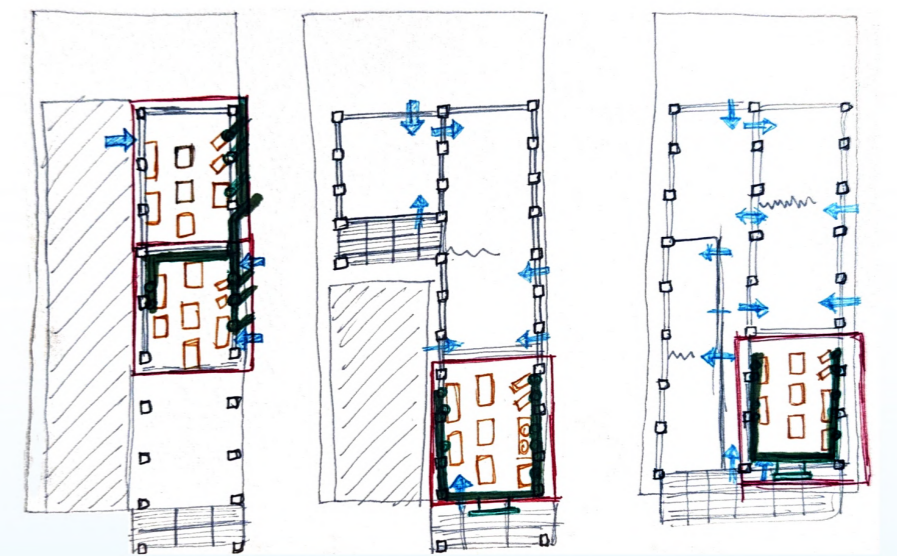

VENTILATION ANALYSIS

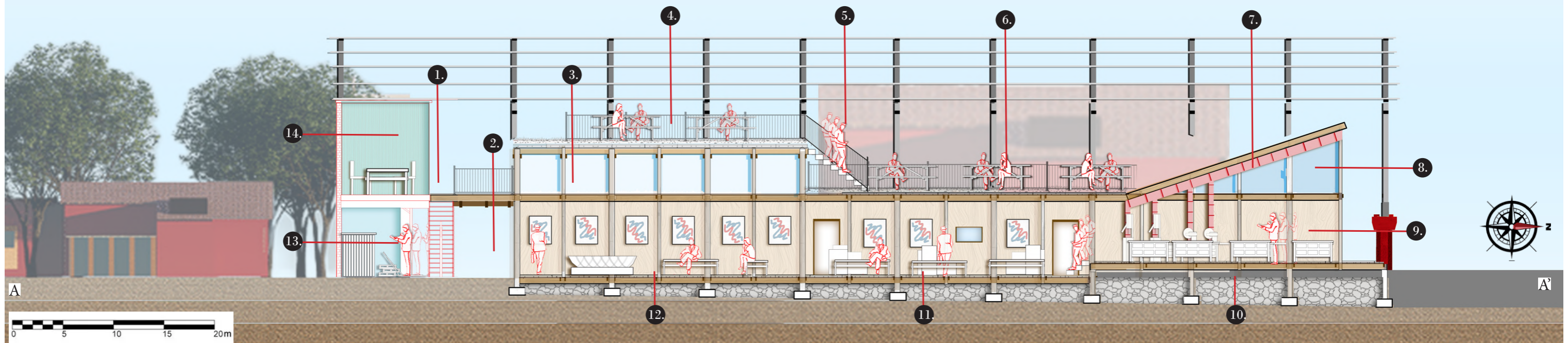

SITE SECTION 2 - 1:200

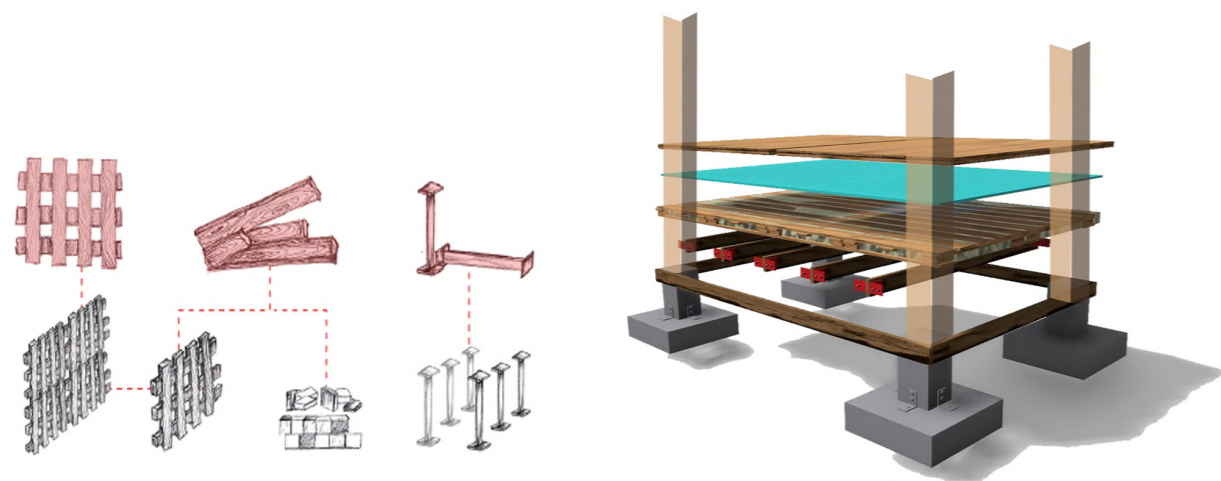

PROJECT : Walmer Creche
PURPOSE : Use of reclaimed Timber material for construction.



No.	MATERIAL	REASONING
1.	Timber Beams	The reclaimed timber beams can provide a stable decking base along with the pallets and insulation on the rubble gabbion base.
2.	Plyboard	The plyboard sheets present on site are diverse sizes, shaped similar based on the planning grid to produce similarity flattening the floor.
3.	Pallets	The Pallets present on site provide as a proper pre fabricated decks that can be fixed together for a stable ground base.
4.	Concrete Foundations	The easily procured, easily moulded material can act as the perfect foundation for a self build process.
5.	Hardwood Columns	The Columns present on site as spare waste or level raising stairs can act as a 2 in 1 feature being stilts and wall structural support.

FLOORING CONSTRUCTION

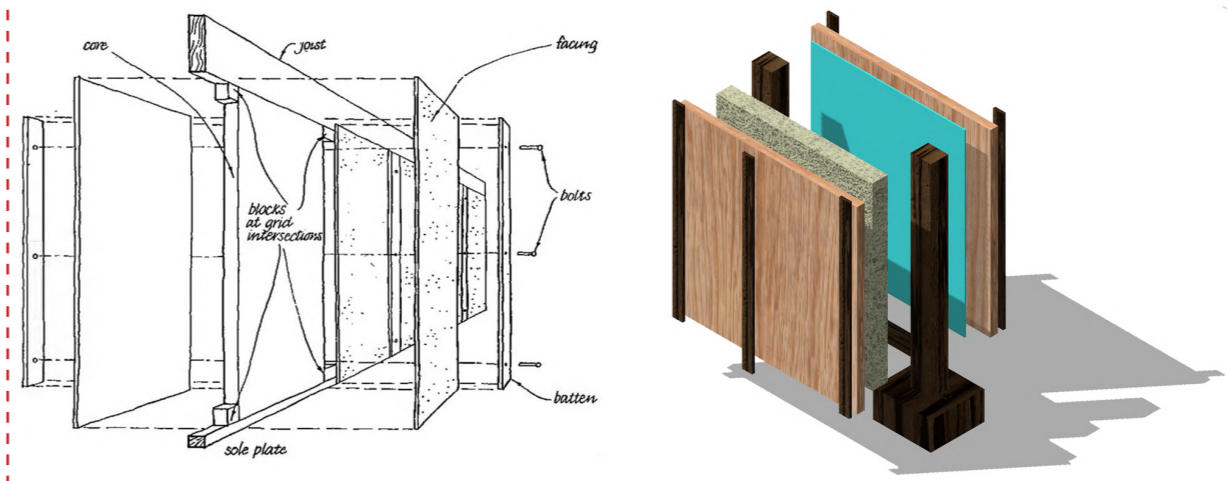

PROJECT : Walters' Way
PURPOSE : Layering of basic timber material in self build scenarios.

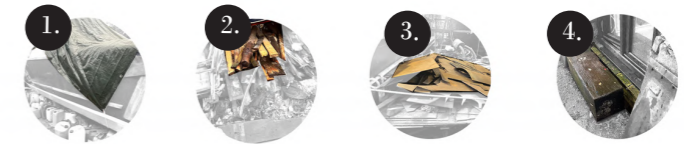

No.	MATERIAL	REASONING
1.	Water resistant Layer	The addition is a necessity based on the moisture on the site, the layer adds an extra safety against dampness passing to the interior.
2.	Timber Beams	The weaker Timber beams can be added to the structure as wall beams to keep the wall layers temporarily without major changes.
3.	Plyboards	The Dual sided layer acts as a blanket safety for the walls, with the plover treatment, it can resist water and with ideal layering avoid fire.
4.	Hardwood Columns	The Columns protruding from the Foundation bases acts as the main structural hold of the structure, acting as wide spaces to fit wall layer.
5.	Insulation	The Addition of ideal insulation can make the structure fire resistant or increase the burn time of the structure.

WALL CONSTRUCTION

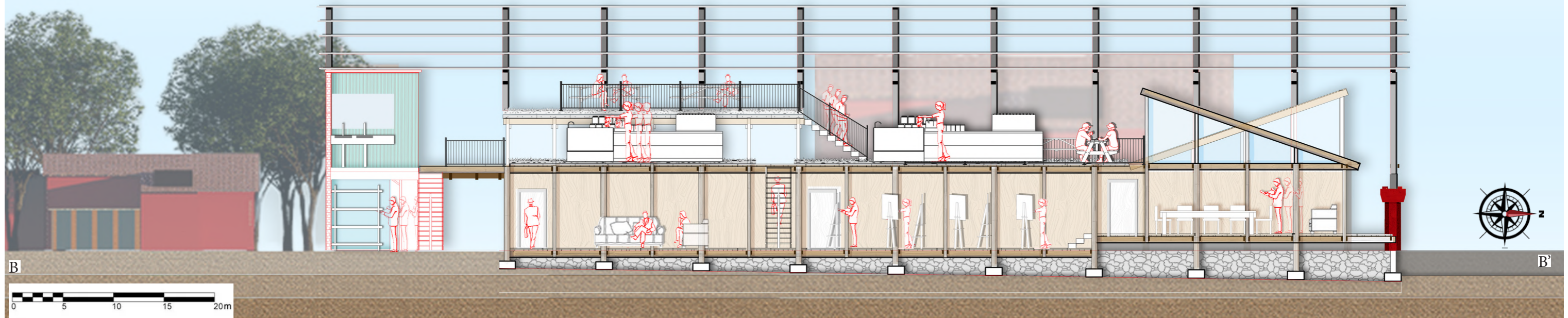



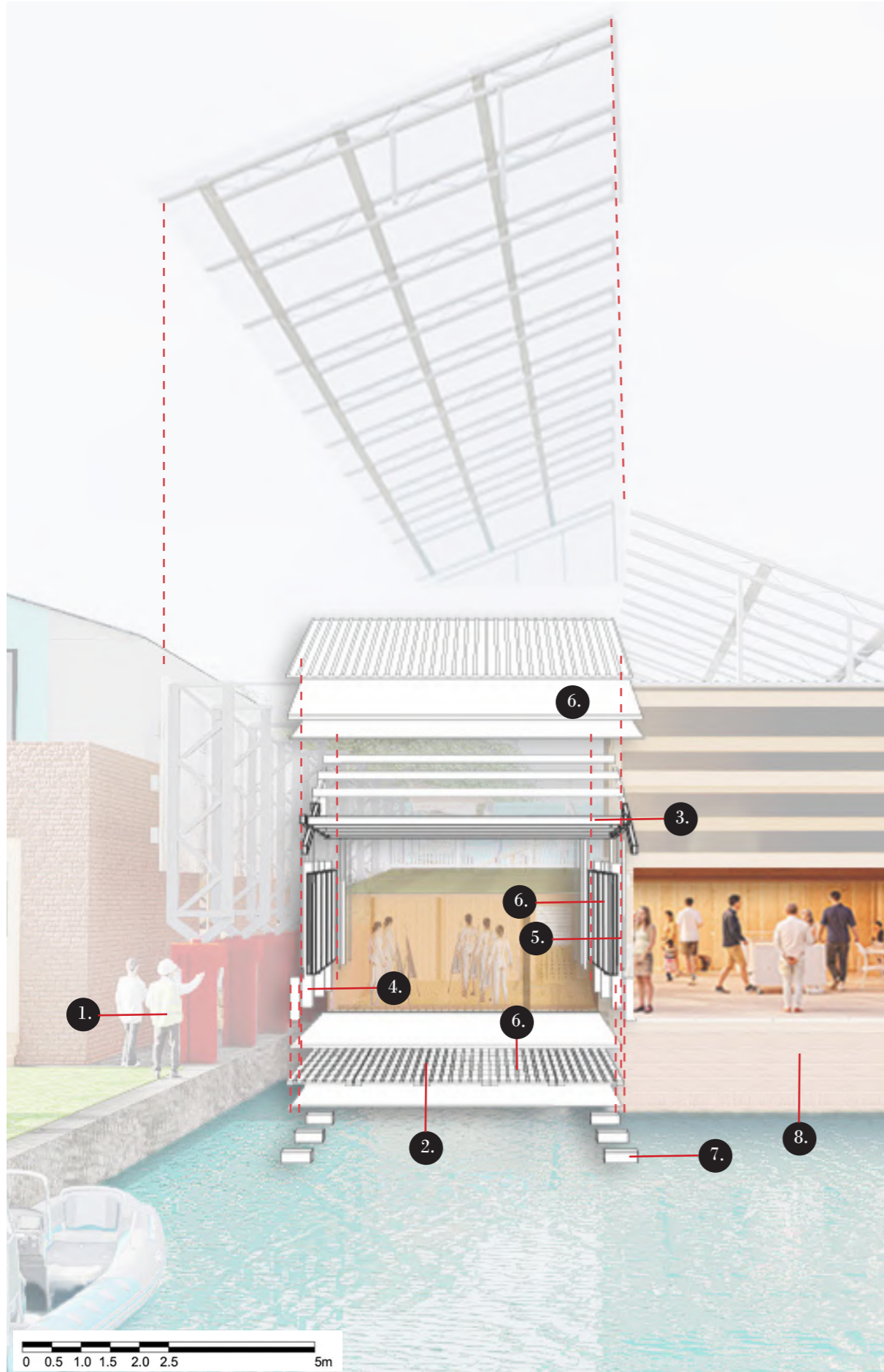

B

B'

EXPLODED SECTION : Construction Material Measurements

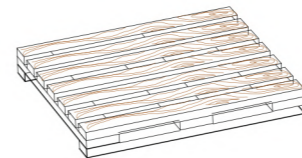
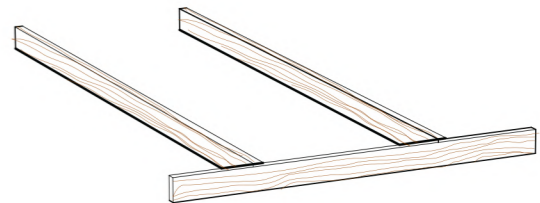

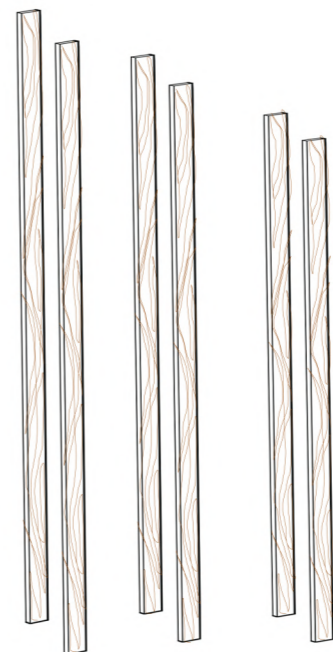
Exploded axonometric highlighting majority construction materials

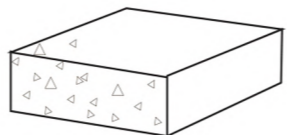
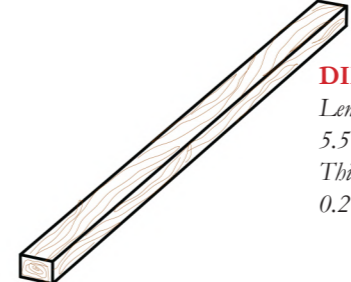
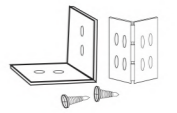
<p>1. CONSTRUCTION LABOUR: Humans</p>  <p>IDEAL HEIGHT: Male - 1.78 m- 1.80 m Female - 166 m</p>	<p>2. FLOORING BASE: Timber Pallets</p>  <p>DIMENSIONS: 1.2 m X 1.1 m Thickness : 0.1 m</p>	<p>3. FLOORING DECKING: Timber beams</p>  <p>DIMENSIONS: Thickness: 0.072 m Height : 0.2 m Length: 3.8 m to 5.5 m</p>
<p>4. WALL STRUCTURAL SUPPORT: Hardwood Columns</p>  <p>DIMENSIONS: Height: 3 m to 5.5 m Thickness: 0.2 m X 0.2 m</p>	<p>5. Wall Support: Timber Beams</p>  <p>DIMENSIONS: Height: 3 m to 5.5 m Thickness: 0.072 m Width: 0.2 m</p>	<p>6. FLOORING & WALLS : Timber Ply Boards</p>  <p>DIMENSIONS: Height: 3 m to 5.5 m Thickness: 0.025 m Width: 1.9 m -3.8 m</p>
<p>7. STRUCTURAL FOUNDATION : Concrete Slab Base</p>  <p>DIMENSIONS: Height: 0.2 m to 0.5 m Width : 0.6 m X 0.6 m</p>	<p>8. ACCESSIBILITY FEATURES : Staircase with Hardwood Columns</p>  <p>DIMENSIONS: Length: 5.5 m Thickness: 0.2 m X 0.2 m</p>	<p>9. CONNECTIVITY ELEMENTS : L Brackets, hinges and bolts</p> 

CONSTITUENT PROPOSAL MODEL : 1:20



- 1. Connectivity between Foundation Columns and flooring
- 2. Roof pallets Connectivity
- 3. Roof Extension connection to Wall columns
- 4. Flooring Pallet base

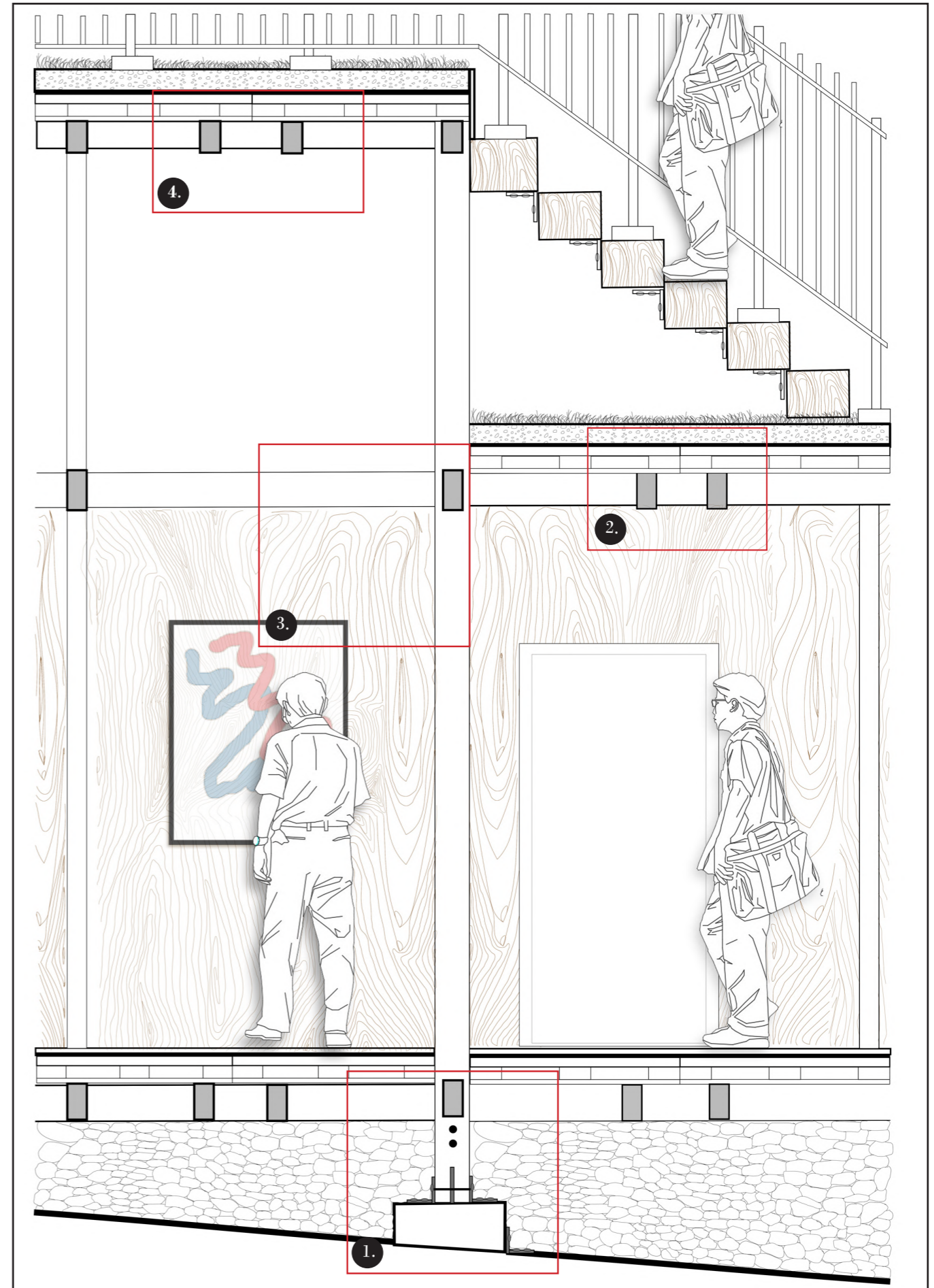
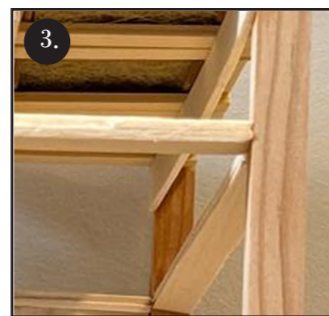
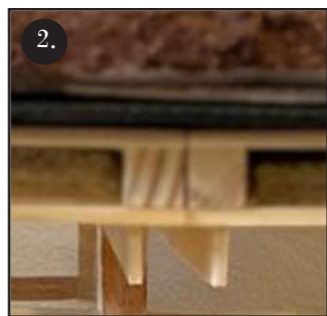
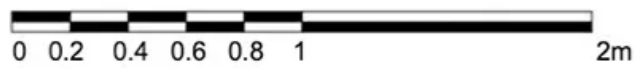

SITE AXONOMETRIC : *Construction Process Details Mid Phasing*

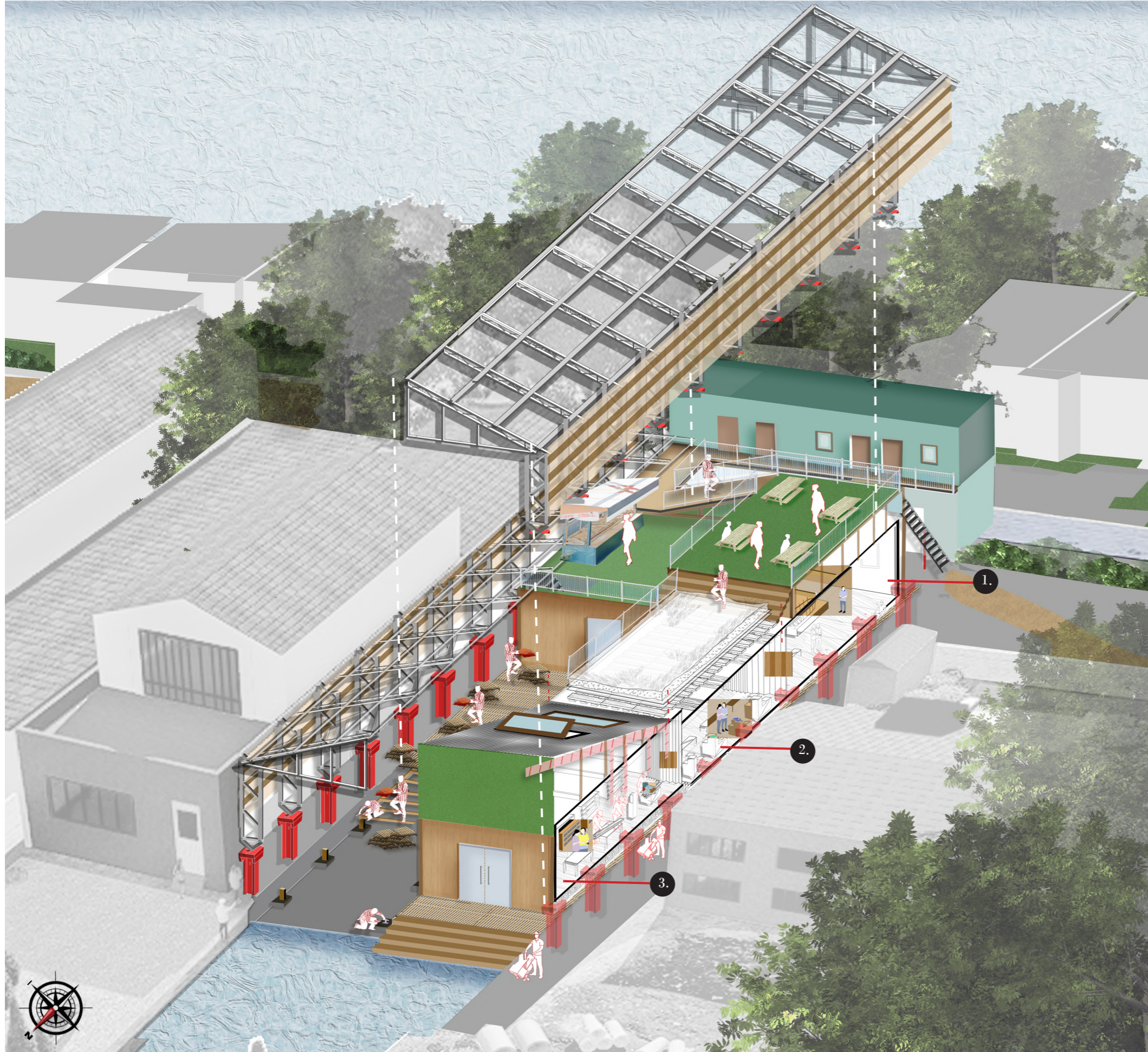

1.

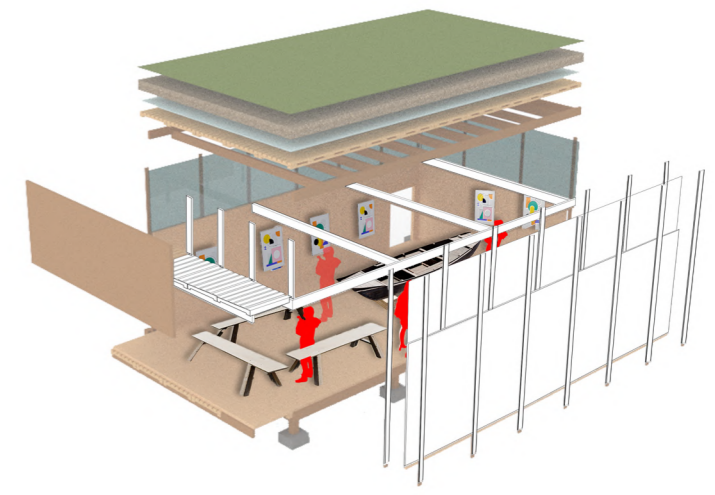

EXHIBITION SPACE 1: *Boatdrelling oriented*

2.

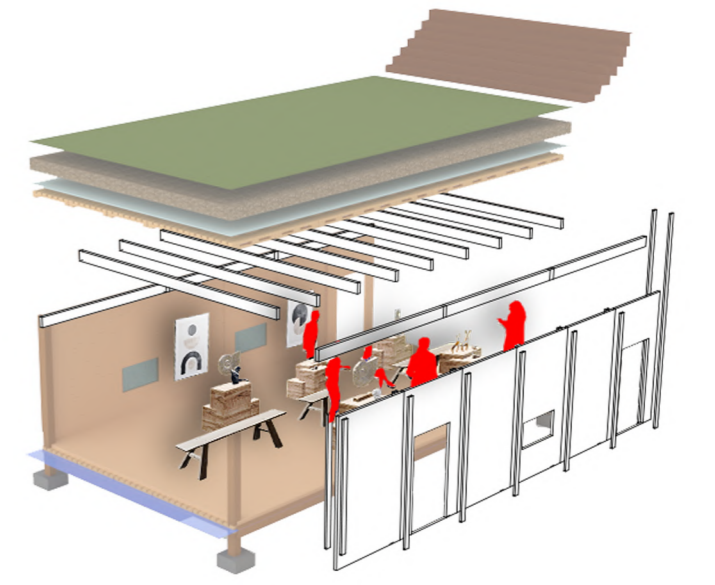

EXHIBITION SPACE 2: *Ceramics oriented*

3.

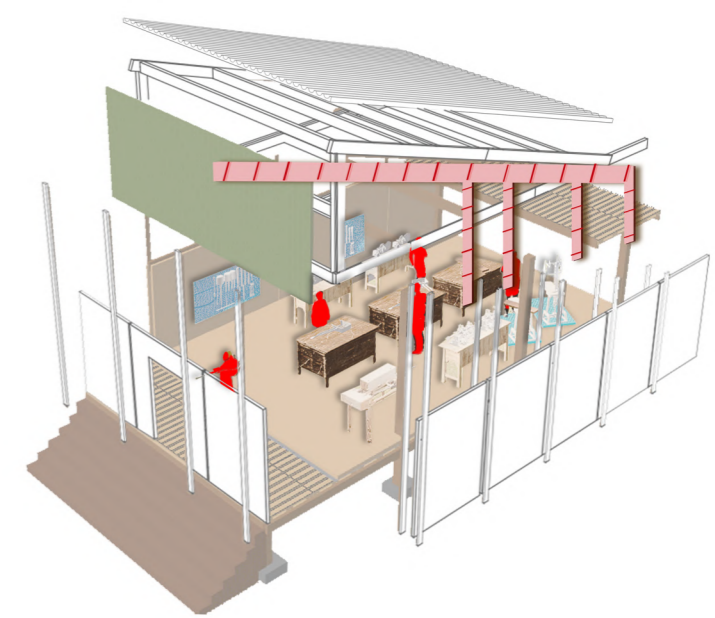

WORKSHOP SPACE: *Structural Management*

SITE EXPLODED AXONOMETRIC : *Use Of Space highlighting Important sections & Textures*



The Highlight showcases the presence of a roof top cafe in connection to ramp connectivity in the background, displaying the timber textures used in construction.

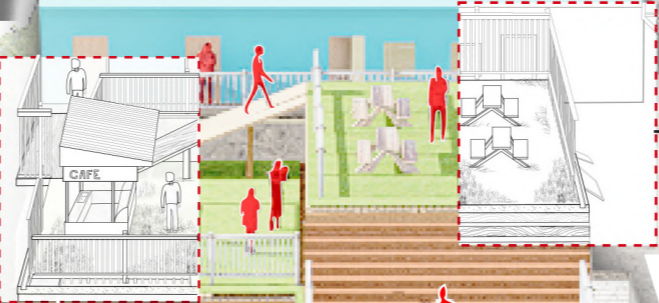

The Highlight showcases the presence of Roof seating showing the furniture elements, roof end gutter system and the edge opening of ventilation windows of the room below

The Highlight showcases the Reception area with the background of material sorting shelving in the back and the base truss of existing ramp, highlighting textures on site.

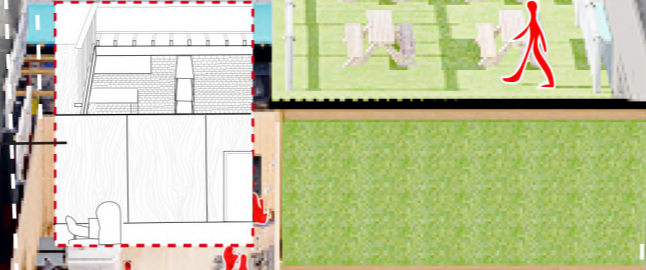

The Highlight showcases the Interior view of workshop usage and the exterior textures of timber plyboard and imber pallets for decking

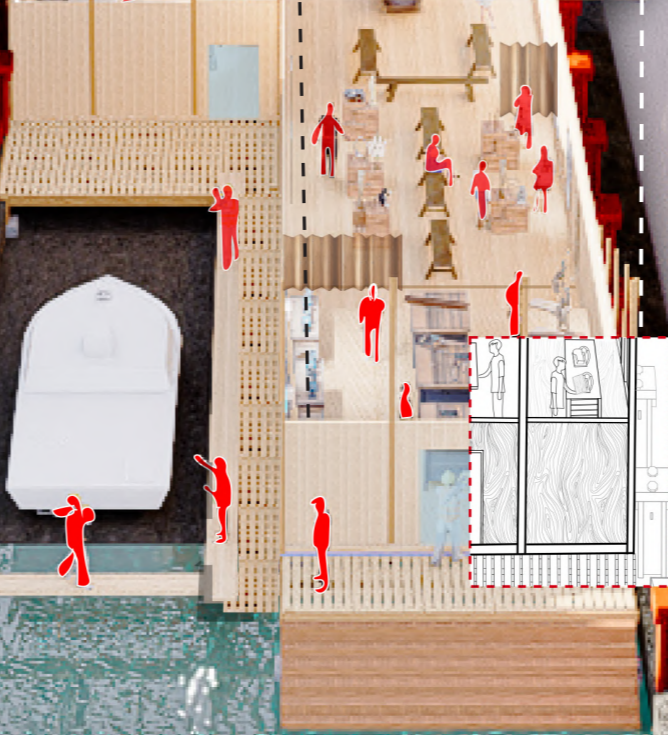

SITE VIEWS : *Interior*

1. Exhibition Room



2. Connecting Reception Room



3. Mixed Workshop Space

1. EXHIBITION ROOM

The image showcases the set up of furniture to present the site's locally produced artwork in a manageable manner to alternate for the wide spread open day.

2. CONNECTING RECEPTION ROOM

The image showcases the Phase 2 Reception space that acts as a mid time connection space for the function transition on site, leading an access route to the roof.

3. MIXED WORKSHOP SPACE

The image showcases the Working of the workshop on site, its intentionally placed towards the entry to inculcate proper lighting and ventilation away from the island. The workshop offers a mix of wood and metal work machines intended to manage the site.

SITE VIEWS : *Exterior*

SITE MAIN ACCESS ROUTE CONNECTING EXISTING ENTRANCES

The image showcases the view of the original entrances connection, after the inclusion of the proposed design, the view showcases the deliberate design of a double heighted ramp opening to allow enough light to the main access crossing of the site.



PROPOSAL ROOF VIEW AND FUNCTION OF ADDITION ROOF LIGHT WINDOWS

The image showcases the view of the original entrances connection, after the inclusion of the proposed design, the view showcases the deliberate design of a double heighted ramp opening to allow enough light to the main access crossing of the site.

SITE WELL BEING : *Fire safety and structural Analysis*

The self build feature can be carried along on site based on the spatial safety and accessibility, the analysis reflects on the site's fire safet, distribution of load in the structure for adequete stability and ways to keep timber Safe from Water (site corresponding impact) anf fire.

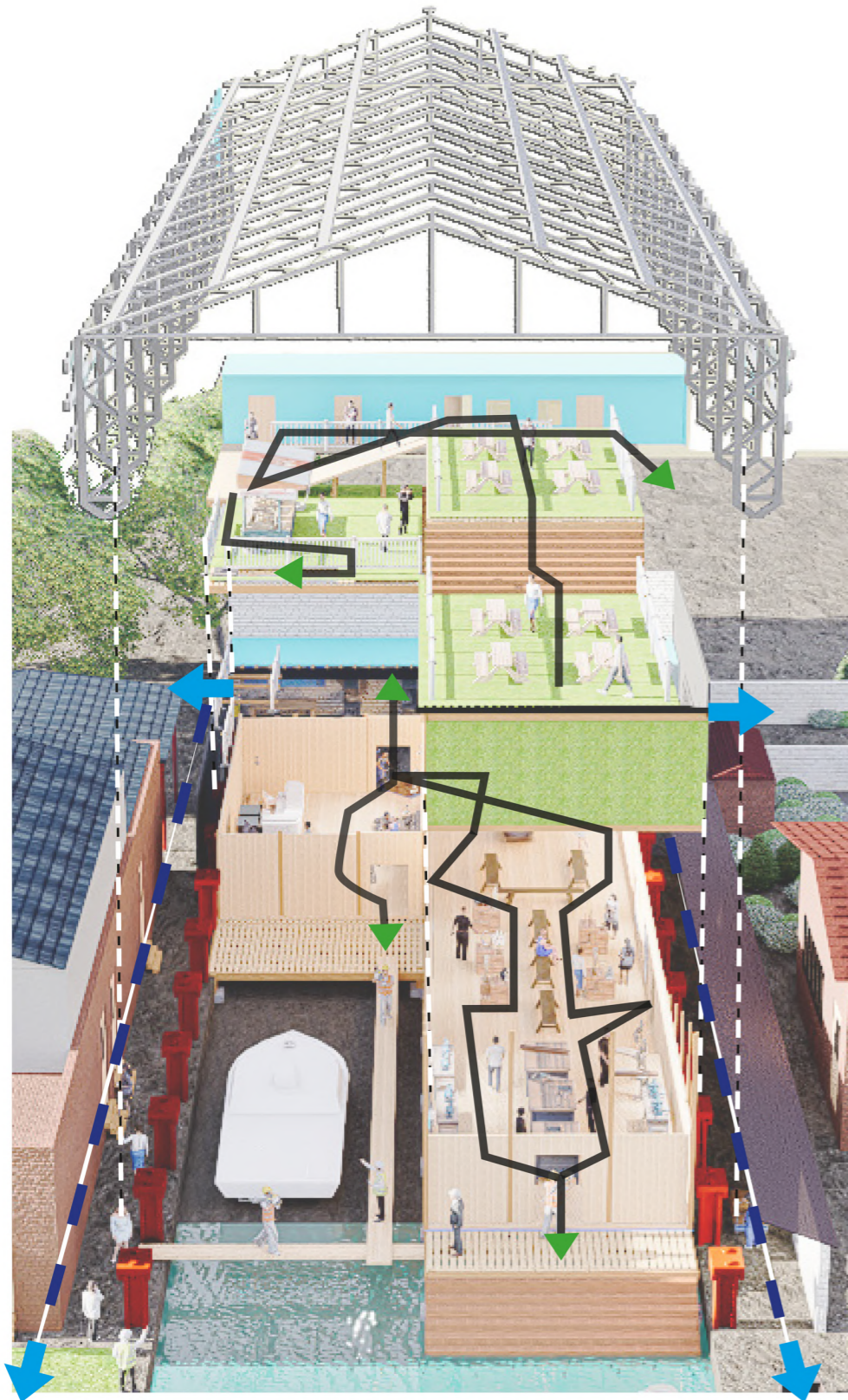

◇ Fire Accessibility in axonometric view (MID PHASING)

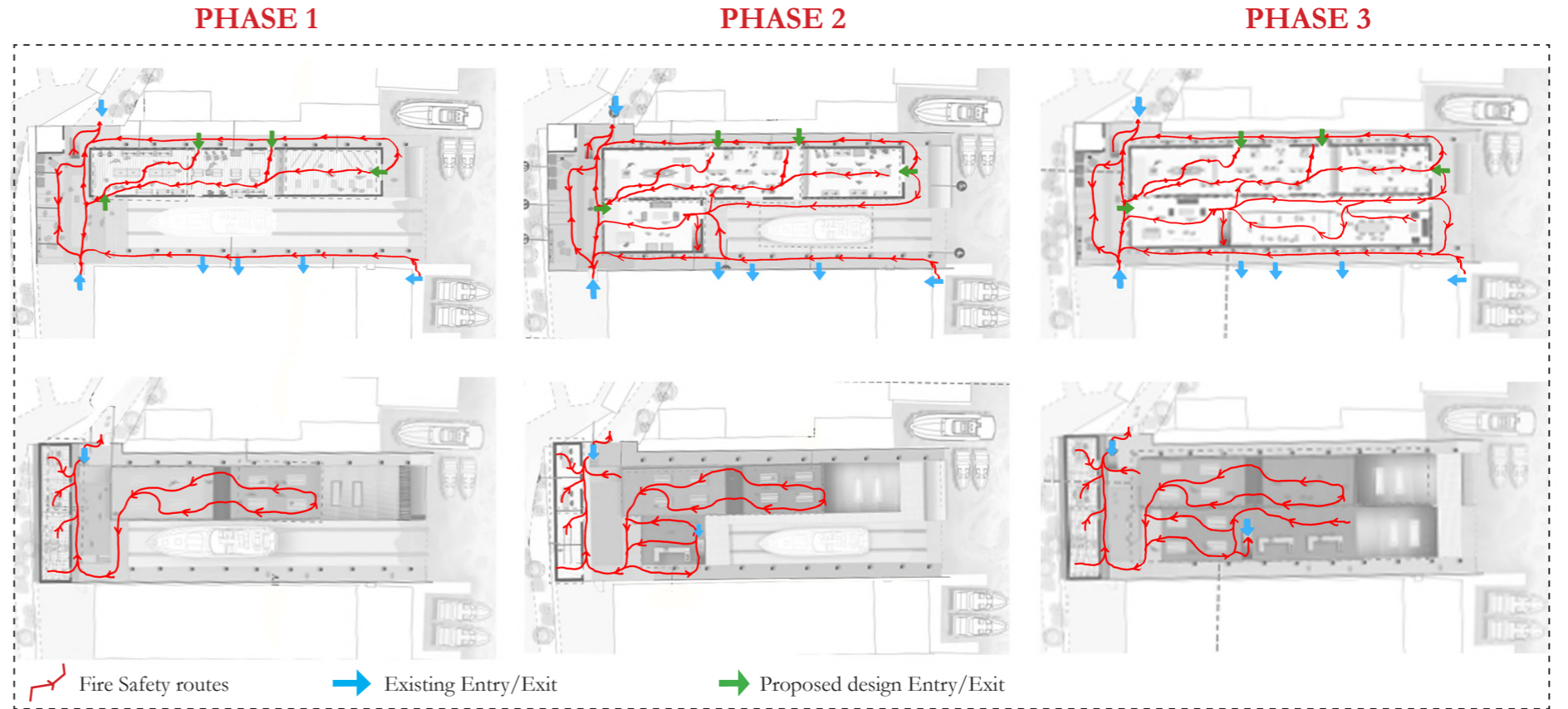

Fire Safety Access routes on Site based on Each Phase

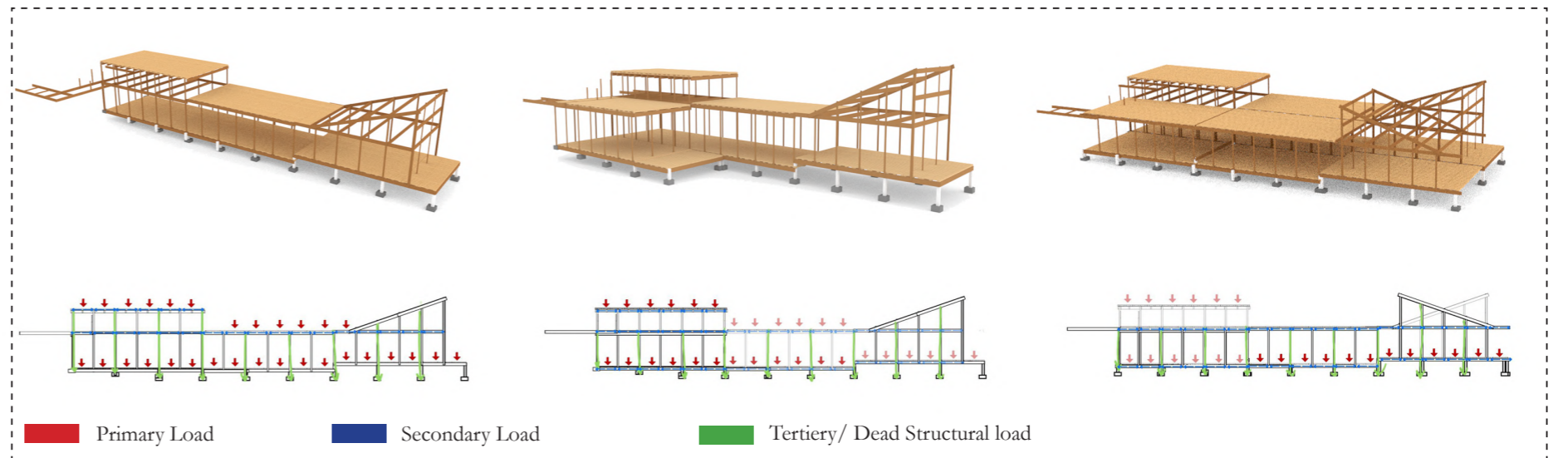

Structural Load Paths based on each Phase



◇ WATER RESISTANCE :Silicon base water Repellent



◇ FIRE SAFETY : Fireshield Intumescent Timber Coating

A clear coating option to make the exterior timber plyboard waterproof to stay safe in a humid site condition on the island.

A coating option for the timber to provide it an extra layer of thickness in case of fire or excessive heat to protect indoors.

SITE ENVIRONMENTAL IMPACT : *Rain Water Harvesting, Ventilation & Passive Cooling*

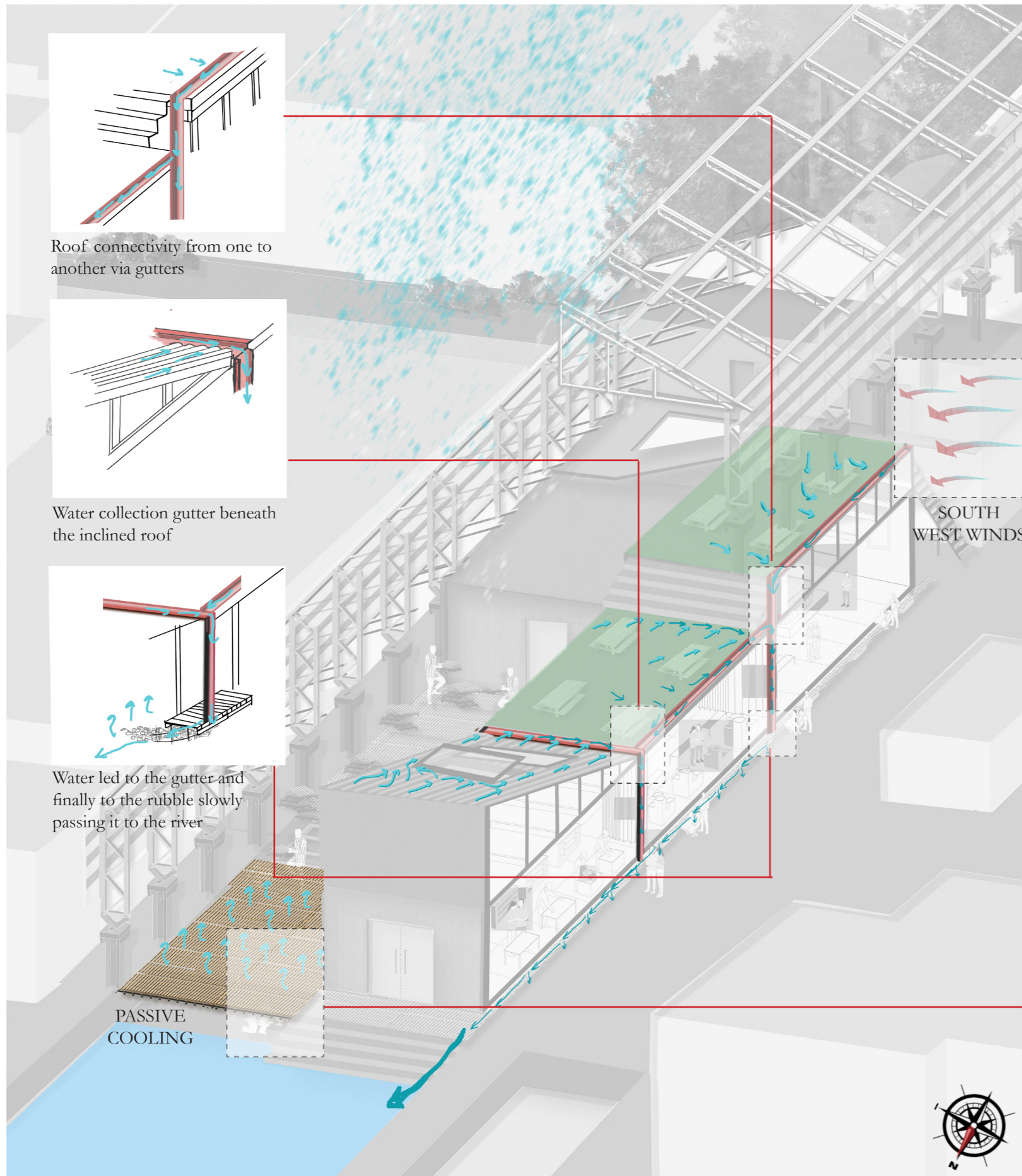

Site Rain Water Harvesting via gutter system leading water to the rubble, slowly transferring to the actual water body

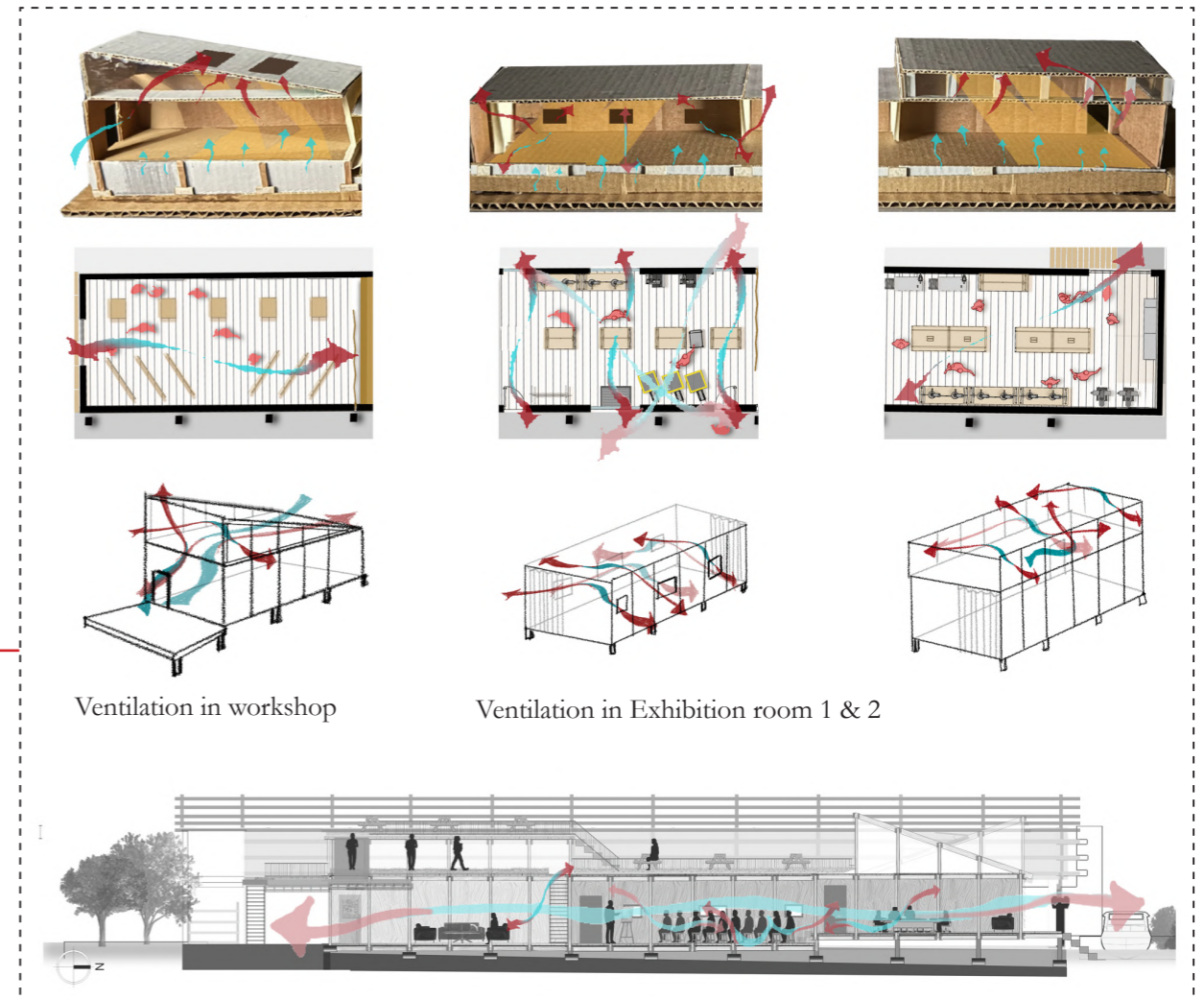

Site Ventilation Analysis based on individual and overall basis

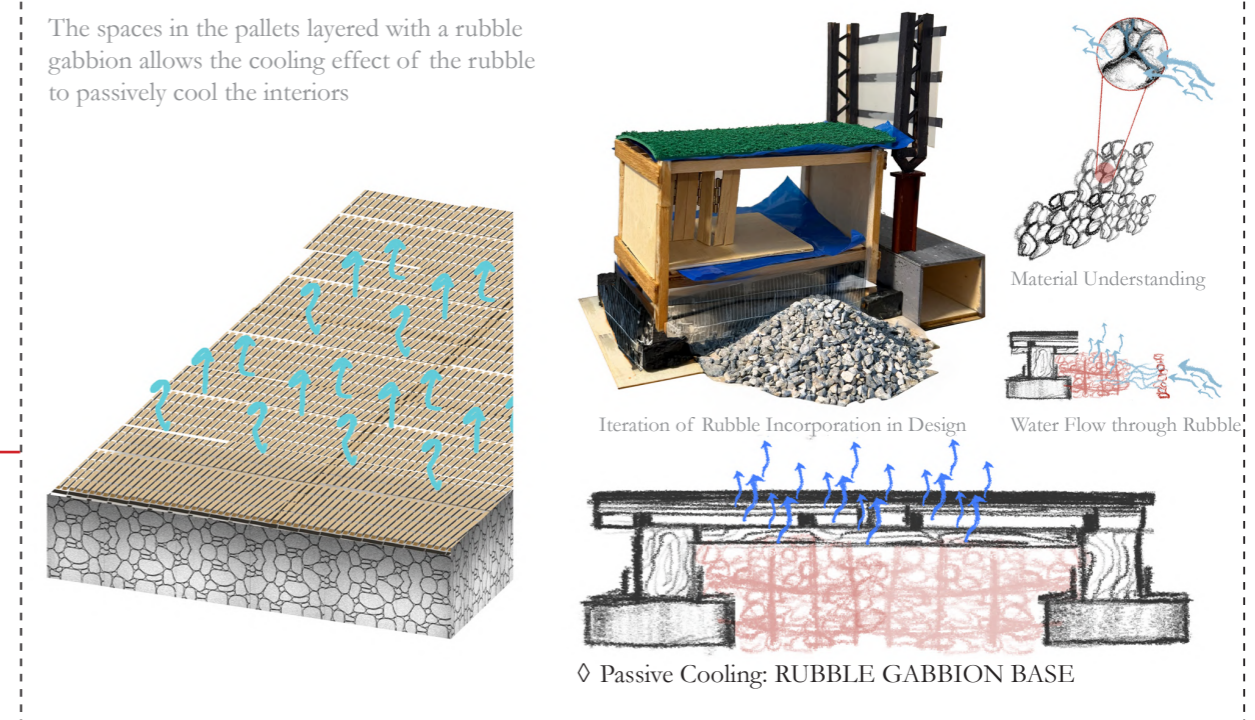

Site Passive Cooling from the rubble filling base