

ORIGINAL ARTICLE

Magnetotactic bacteria used to generate electricity based on Faraday's law of electromagnetic induction

B.A. Smit¹, E. Van Zyl¹, J.J. Joubert¹, W. Meyer², S. Prévéral³, C.T. Lefèvre³ and S.N. Venter¹ 

¹ Department of Microbiology and Plant Pathology, University of Pretoria, Pretoria, South Africa

² Department of Physics, University of Pretoria, Pretoria, South Africa

³ CNRS/CEA/Aix-Marseille Université, UMR7265 Biosciences and Biotechnologies Institute, Laboratoire de Bioénergétique Cellulaire, Saint Paul lez Durance, France

Significance and Impact of the Study: This study provides proof-of-concept of electromagnetic induction using magnetosomes or magnetotactic bacteria in an experimental setup based on the law of Faraday. The concept of using these bacteria or their biomineralized magnetic nanoparticles as a biological alternative in low voltage electricity generation has the potential to be further explored and developed.

Keywords

electricity, electromagnetic induction, Faraday's law, magnetosomes, magnetotactic bacteria.

Correspondence

Stephanus N. Venter, Department of Microbiology and Plant Pathology, University of Pretoria, Private Bag X 20, Hatfield, Pretoria 0028, South Africa.

E-mail: Fanus.Venter@up.ac.za

2017/2485: received 8 August 2017, revised 5 February 2018 and accepted 5 February 2018

doi:10.1111/lam.12862

Abstract

Magnetotactic bacteria (MTB) have the unique ability to produce magnetic particles surrounded by a biomembrane to form the magnetosome organelle. Therefore, MTB have novel physical and magnetic properties and have consequently been used in several biotechnological applications. The magnetic properties of these micro-organisms and their magnetosomes have, however, never been used for the generation of electricity as described in this letter. Comparisons were made between, firstly, the electricity generated from purified magnetosomes, MTB culture (bacterial cells with magnetosomes) and sterile, liquid growth medium (control). Secondly, the electricity generated by a dilution series of purified magnetosomes were compared. A statistically significant difference was found between the voltage measured from the purified magnetosomes (highest voltage), MTB culture (lower voltage) and liquid growth medium (lowest voltage). In the dilution series, the voltage measured increased as the magnetosome concentration increased, but only up to an optimum concentration ($0.0376 \text{ mg ml}^{-1}$). In this study, we have demonstrated that a significantly higher voltage than that of the control could be measured when MTB or purified magnetosomes were pumped through a solenoid by applying Faraday's law of electromagnetic induction.

Introduction

Magnetotactic bacteria biomineralize intracellular organelles composed of a phospholipid bilayer membrane with bound magnetite (Fe_3O_4), greigite (Fe_3S_4) or both crystals. These magnetosomes are used during magnetotaxis, in conjunction with chemotaxis, which enable the bacteria to reach optimal growth conditions in aqueous environments (Lefèvre and Bazylinski 2013). The magnetosome biomineralization is genetically controlled (Uebe and Schüler 2016) and it has been suggested that magnetosome formation is linked to environmental conditions

such as oxygen availability (Bazylinski *et al.* 2013). Individual magnetite crystals in MTB have a diameter of between 35 and 120 nm, thus placing it in the single magnetic domain size range. This gives the magnetosomes the highest possible magnetic moment per unit volume. Usually the magnetosomes are in straight chains to optimize the magnetic dipole moment which gives it the ability to passively align the cell according to the earth's geomagnetic field lines even when cells are dead (Frankel 1984; Bazylinski and Frankel 2004).

The potential application of MTB in various fields has made an impact, especially on biomedical research. Most

recently, MTB were reported as a possible treatment for malaria (Murugan *et al.* 2017). The use of magnetosomes as a potential antitumour drug carrier has also been successfully applied (Sun *et al.* 2008). Magnetotactic bacteria are also used for the improved imaging of tumours by magnetic resonance imaging (MRI) (Mériaux *et al.* 2015) and (Boucher *et al.* 2017). Furthermore, it has been suggested that cancers could be treated using magnetosomes in magnetic hyperthermia (Alphandéry *et al.* 2012). Photothermal therapy using magnetosomes is also considered as potential cancer treatment (Chen *et al.* 2016). Other applications of MTB in biotechnology include biological phosphate removal with *Magnetospirillum gryphiswaldense* (Zhou *et al.* 2017), organophosphate pesticide biodegradation with magnetosomes acting as nanobiocatalysts (Ginet *et al.* 2011), biosorbents for heavy metals (Zhou *et al.* 2012) and bioremediation of cobalt (Tajer-Mohammad-Ghazvini *et al.* 2016). Lastly, it has been shown that magnetosomes can immobilize enzyme activity such as uricase and glucose oxidase. However, magnetosomes proved to be 40 times more effective in immobilizing these enzymes compared to artificial magnetic particles and 100 times more effective compared to magnetic iron-zinc particles (Matsunaga *et al.* 1996).

Micro-organisms have been employed to produce alternative forms of energy as well as recently discovered electricigens. Electricigens are able to oxidize organic compounds to carbon dioxide completely with electrodes being the sole electron acceptor while still maintaining sufficient electron transfer for growth. *Shewanella* and *Geobacter* species have been used as electricigens (Lovley 2006). In the case of *Shewanella*, electron transfer does not take place directly but with electron shuttles, whereas with *Geobacter* electron transfer to the electrodes do take place directly in a microbial fuel cell setup (Reguera *et al.* 2005). Thus, *Geobacter* has an advantage over *Shewanella* as *Shewanella* incompletely oxidizes organic acids such as lactate (Lovley 2006). There are other lesser-known electrogenic bacteria used to produce electricity such as *Dietzia* and *Pseudomonas* species. *Dietzia* sp. typically forms biofilms that secrete redox mediators (Sacco *et al.* 2017), *Pseudomonas* species also use mediators for electron transfer (Mavrodi *et al.* 2001). The potential of MTB in the field of energy production has not been explored using electromagnetic induction.

Faraday's law of electromagnetic induction states that if a magnetic field changes relative to a solenoid, an electromagnetic force is induced on the solenoid (Faraday 1832). The aim of this study was to investigate the possibility that MTB and/or pure magnetosomes could potentially be used to convert mechanical energy into electrical energy, using the principle of electromagnetic induction. A mini (pilot) setup was used to investigate whether a

net voltage could be measured when magnetosomes/MTB were pumped through copper coils.

Results and discussion

The magnetotactic bacterium, *Magnetospirillum magneticum* strain AMB-1 was used in this study to test whether this bacterium or its purified magnetosomes could be used to produce an electromotive force. The bacterium produced an average of 15 magnetosomes per cell when grown in culture medium (Fig. 1a). Upon investigation of the extracted and purified magnetosomes, it was observed that the magnetosomes remained in suspension, and did not form aggregates (Fig. 1b). The magnetosome membrane was also observed to be still surrounding the magnetic particles (Fig. 1c).

As shown in Fig. 2 the experimental setup consisted of a capillary (thin end of a Pasteur pipette) placed between two poles of an electromagnet (0.5–0.6T) (Leybold, 56214; powersource: Iso Tech IPS 303DD transformer). Before the pipette was placed between the poles, copper wire (0.1 mm diameter and enamelled) was spun around the pipette starting at a distance of 8 cm from the tip to create a 3 mm × 3 mm cylindrical coil (solenoid) around the pipette. The distance between the electromagnet and the solenoid was 0.5 cm with solutions passing through the magnetic field first and then the solenoid. The ends of the copper coil were connected to a multimeter (Hewlett Packard 34970A) which captured the data.

A plastic pipe from the peristaltic pump (Watson Marlow 205S) was connected to the large end of the pipette. The experimental solutions and controls were pumped through the pipette, passing through the magnetic field and coil. Solutions were pumped at a flow rate of 4.4 ml min⁻¹.

Voltage measurements were taken every second and the multimeter recorded the average value over each second. With power line frequency synchronization, the background interferences were suppressed with each measurement. The averages of each second were used to present the results graphically. For representation of the data the same measurements were split into positive (Fig. 3) and negative (Fig. 4) values. This was done in order to calculate the alternating current correctly. Measurements were repeated between 3 and 5 times under identical conditions to keep the electrical background interference the same. The first and last 5-s of each series of measurements were discarded as operation of the pump or computer sometimes created interferences. In order to limit the unavoidable background interferences from the surroundings it was also important that the multimeter had the ability to integrate and synchronize the data.

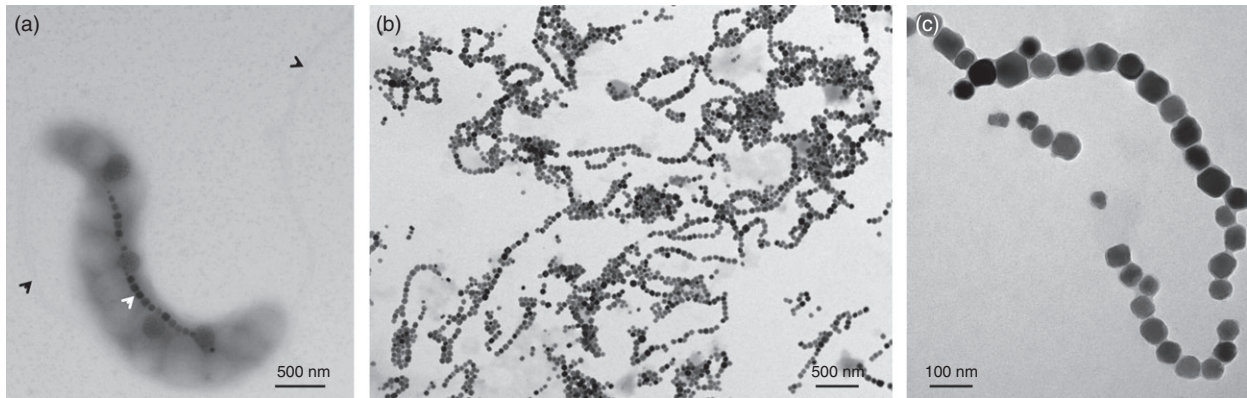

Figure 1 Transmission electron microscope (TEM) images of magnetosomes and the magnetosome membrane. (a) TEM micrograph of a cell of *Magnetospirillum magneticum* strain AMB-1 deposited onto a Formvar-coated electron microscope grid showing a chain of magnetosomes (white arrowhead) and the two polar flagella of the cell (black arrowhead). (b and c) TEM micrograph of extracted and purified magnetosome chains showing cuboctahedral magnetite crystals surrounded by the magnetosome membrane.

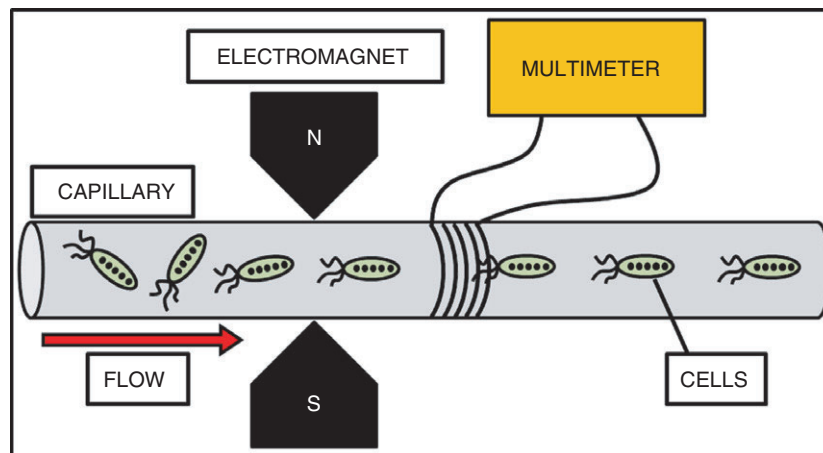

Figure 2 Diagrammatic representation of the experimental setup in which the voltage produced by different materials was tested. The suspensions were pumped from left to right in the capillary and magnetic materials were aligned by the electromagnet if it was needed. Materials then passed through the solenoid and induced an emf on the coil. This voltage was then measured by the multimeter and analysed. [Colour figure can be viewed at wileyonlinelibrary.com]

The voltage measurements for the induction experiments are shown as positive and negative values respectively (Figs 3 and 4, Tables S1 and S2) to demonstrate the observed alternating current. The results clearly indicated that the uninoculated growth medium (negative control) produced the lowest voltage, the AMB-1 culture in the liquid growth medium a higher voltage and the pure magnetosomes suspended in liquid growth medium, the highest voltage. From the dilution series it was observed that the voltage increased as the magnetosome concentration increased, but only up to a certain concentration ($0.0376 \text{ mg ml}^{-1}$), where, interestingly, the voltage dropped steeply (results not shown). The analysis of variance was performed on both tests (with null hypotheses $\mu_{\text{medium}} = \mu_{\text{culture}} = \mu_{\text{magnetosomes}}$ and

$\mu_{\text{low concentration}} = \mu_{\text{medium concentration}} = \mu_{\text{high concentration}}$) according to D'Agostino *et al.* (2006). The analysis of variance test confirmed that the sets of data displayed were significantly different from each other (Tables S1 and S2).

Here, we have successfully shown the possibility to produce energy with MTB and magnetosomes. The fact that an alternating current has been measured can be ascribed to the magnetic nanoparticles passing completely through the solenoid as separate magnetosomes or magnetosome strings. This observation was also reported for the first time by Faraday (1832) in his original study with magnets and we hereby confirm his findings in this novel approach. Furthermore, if the magnetosomes were inducing a current as separate magnetosomes and acting as a

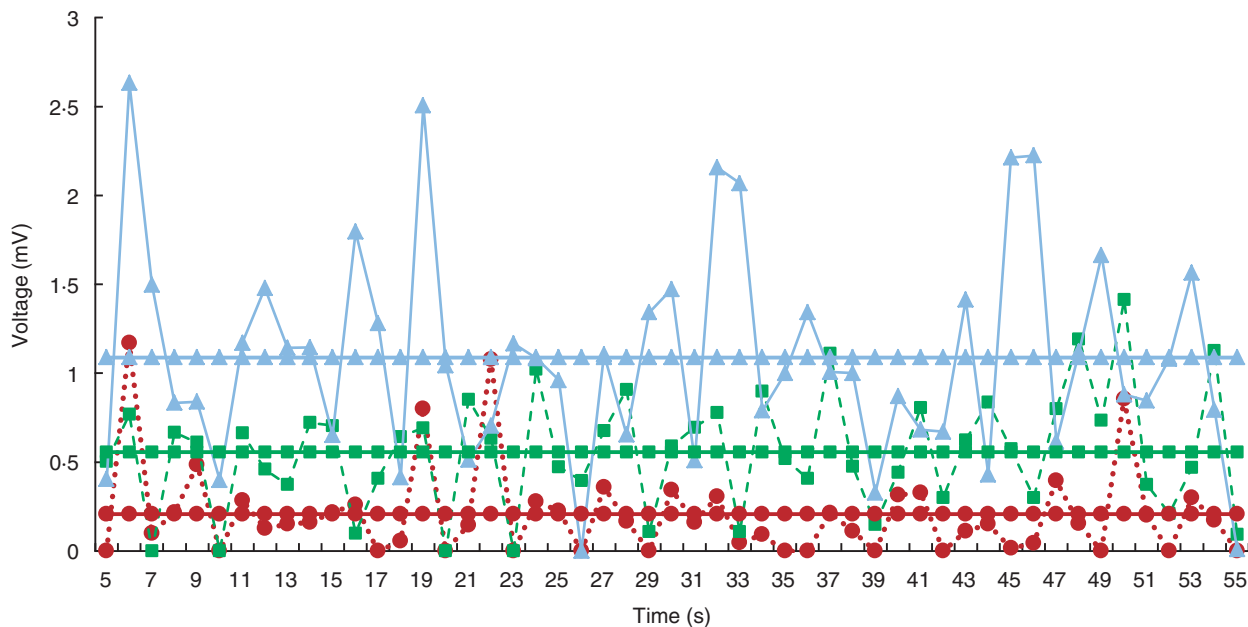

Figure 3 Positive voltage measured from uninoculated growth medium (•••••), liquid AMB-1 culture (•••••) and magnetosomes (•••••) suspended in liquid growth medium. Horizontal lines represent the average value of each test over the 55 s: magnetosomes 1.09 mV, liquid AMB-1 culture 0.56 mV and uninoculated growth medium 0.21 mV. [Colour figure can be viewed at wileyonlinelibrary.com]

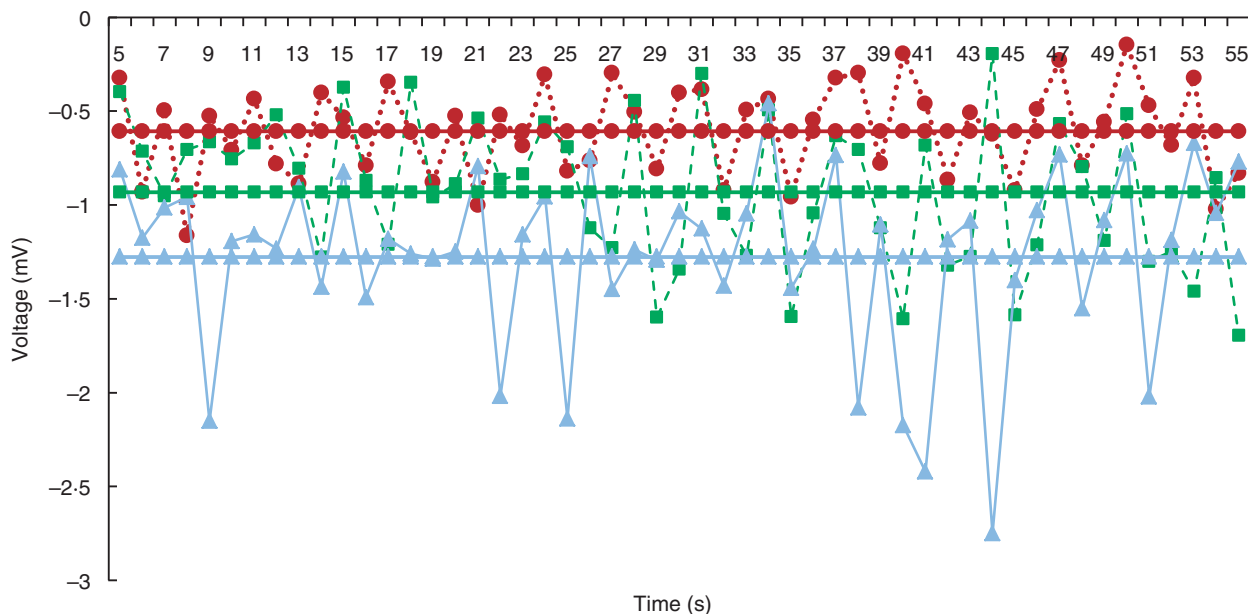

Figure 4 Negative voltage measured from uninoculated growth medium (•••••), liquid AMB-1 culture (•••••) and magnetosomes (•••••) suspended in liquid growth medium. Horizontal lines represent the average value of each test over the 55 s: magnetosomes -1.28 mV, liquid AMB-1 culture -0.93 mV and uninoculated growth medium -0.61 mV. [Colour figure can be viewed at wileyonlinelibrary.com]

uniform distribution, then an alternating current could also possibly be explained by the peristaltic actions of the pump. As the last roller of the pump squeezed the tube, liquid were pushed forward at a faster rate for a very brief

moment. On the other hand, the reverse could occur: as the flattened tube was released, the liquid could flow for a brief moment in the opposite direction in relation to the coil, which could have caused a negative voltage and

Downloaded from https://academic.oup.com/lambio/article/66/5/362/6699185 by guest on 06 February 2023

thus an alternating current could be generated. Another explanation for an alternating current could be that the magnet held magnetosomes with the magnetic force at the pole until many magnetosomes caused a flow obstruction and were then released as a slightly higher concentration. This might have caused an alternating current as the magnetosome distribution was not uniform, but in effect, a dipole was created.

In the experiment with the magnetosome dilution series, the voltage measured was directly related to the magnetosome concentration. The increase in voltage and sudden drop as the magnetosome concentration increased can possibly be explained by the number of magnetosomes attached to each other because of their magnetism. It can be shown that magnetic balls placed in a straight line touching each other will form a circle as more magnets are attached. We postulate that the same phenomenon occurred as the concentration of magnetosomes increased. The string of magnetosomes formed a circle and the magnetic field lines of the circle were concentrated towards the centre. In the case of a straight string, the magnetic field lines would protrude from the ends, resulting in a higher voltage due to more magnetic field lines moving through the solenoid (Giambatista *et al.* 2013).

A net voltage (millivolts) was measured in the novel manner described in this paper and we have successfully proven this concept. Although the emf was only in the millivolt range, it has the potential for many applications. This study adds knowledge to the field of applications involving MTB, and suggests that MTB and their magnetosomes can potentially be utilized as an alternative source of electrical energy, especially where millivolts are required. We realize that the electrical energy generated is not economical as we used a peristaltic pump to simulate the cells' swimming ability. In further studies the economical output could be addressed as we believe our setup can be improved. Moreover, the electricity production using MTB is not yet competitive compared to what is produced with *Geobacter* (Bond and Lovley 2002) for instance but our proof of concept we present here along with progresses in MTB cultivation could make our setup competitive in the future. Furthermore, this study could be enhanced by developing a model which can predict the voltage produced in relation to the magnetosome or cell concentration. However, as we are not able to determine exactly in which conformation (rings, individual or strings) the magnetosomes or cells were passing through the coil, a model of this scale is not in the scope of this letter but may be beneficial to a larger paper. In further studies the effect of different magnetosome sizes, amounts and orientations in different species as well as other factors, such as, magnetosome membrane and cell wall thickness and cell size could be measured.

Materials and methods

Growth of MTB and magnetosome purification

Magnetospirillum magneticum (AMB-1) was grown at 28°C in defined media described by Mériaux *et al.* (2015). Cultures in late-exponential growth phase were used in all the experiments. Cells might have died during the course of experimental work, but as we used a constant flow, this would not have had any effect on the induction. Magnetosomes of strain AMB-1 were extracted and purified according to Mériaux *et al.* (2015).

Controls and experiment

AMB-1 liquid culture and AMB-1 magnetite magnetosomes (3.39 mg ml⁻¹ suspended in 30 ml of uninoculated liquid culture) were used in the described setup to test for induction. Uninoculated AMB-1 liquid media acted as the negative control. A bar magnet was brought next to the coils to confirm that the experimental setup was functional as seen by the change in voltage. The voltage produced by a dilution series of magnetosomes, suspended in physiological salt water (0.9% sodium chloride), was also measured. The initial concentration of the magnetosome suspension was 0.113 mg ml⁻¹. This suspension was diluted 1 : 3 and 1 : 9.

Microscopy of magnetosomes and MTB

For TEM imaging, 10 µl deposits of a culture or diluted magnetosomes suspension were allowed to sediment for one minute onto 200 mesh copper grids covered by a formvar-carbon film. After removal of the liquid with Kimwipe paper, digital electron micrographs were recorded with a Tecnai™ G2 BioTWIN transmission electron microscope (FEI Company, Hillsboro, OR, USA) at 100 kV acceleration voltage.

Acknowledgements

We thank Prof. Marla Tuffin (University of the Western Cape), Bernard Genty, Michel Philibert, Michel Péan and Nicolas Ginet (all from the CEA), Prof. Zander Myburg and Prof. Marion Meyer (both from the UP), Ms Carin de Beer (Hoërskool Waterkloof), Mr Paul Moulang, Ms Helena Coetzee, Mr Andries and Ms Hetty Smit. S.P. and C.T.L. were funded by the French National Research Agency (APP-P2N 2012 and ANR-16-TERC-0025-01).

Conflict of Interest

No conflict of interest declared.

References

- Alphandéry, E., Gyout, F. and Chebbi, I. (2012) Preparation of chains of magnetosomes, isolated from *Magnetospirillum magneticum* strain AMB-1 magnetotactic bacteria, yielding efficient treatment of tumors using magnetic hyperthermia. *Int J Pharm* **434**, 444–452.
- Bazylnski, D.A. and Frankel, R.B. (2004) Magnetosome formation in prokaryotes. *Nat Rev Microbiol* **2**, 217–230.
- Bazylnski, D.A., Lefèvre, C.T. and Schüler, D. (2013) Magnetotactic Bacteria. In *The Prokaryotes – Prokaryotic Physiology and Biochemistry*, eds. Rosenberg, E., DeLong, E.F., Lory, S., Stackebrandt, E. and Thompson, F. pp. 454–485. Berlin, Heidelberg: Springer-Verlag.
- Bond, D.R. and Lovley, D.R. (2002) Electricity production by *Geobacter sulfurreducens* attached to electrodes. *Appl Environ Microbiol* **69**, 1548–1555.
- Boucher, M., Geffroy, F., Prévèral, S., Bellanger, S., Selinque, E., Adryanczyk-Perrier, G., Péan, M., Lefèvre, C.T. *et al.* (2017) Genetically tailored magnetosomes used as MRI probe for molecular imaging of brain tumor. *Biomaterials* **121**, 167–178.
- Chen, C., Wang, S., Li, L., Wang, P., Chen, C., Sun, Z. and Song, T. (2016) Bacterial magnetic nanoparticles for photothermal therapy of cancer under the guidance of MRI. *Biomaterials* **104**, 352–360.
- D'Agostino, R.B.S., Sullivan, L.M. and Beiser, A.S. (2006) *Introductory Applied Biostatistics*, 1st ed. Belmont: Brooks/Cole.
- Faraday, M. (1832) Experimental researches in electricity. *Philos Trans R Soc Lond* **122**, 125–162.
- Frankel, R.B. (1984) Magnetic guidance of organisms. *Annu Rev Biophys Bioeng* **13**, 85–103.
- Giambattista, A., McCarthy Richardson, B. and Richardson, R.C. (2013) *College Physics*, 4th ed. New York: McGraw-Hill.
- Ginet, N., Pardoux, R., Adryanczyk, G., Garcia, D., Brutescio, C. and Pignol, D. (2011) Single-step production of a recyclable nanobiocatalyst for organophosphate pesticides biodegradation using functionalized bacterial magnetosomes. *PLoS ONE* **6**, e21442.
- Lefèvre, C.T. and Bazylnski, D.A. (2013) Ecology, diversity, and evolution of magnetotactic bacteria. *Microbiol Mol Biol Rev* **77**, 497–526.
- Lovley, D.R. (2006) Bug juice: harvesting electricity with microorganisms. *Nat Rev* **4**, 497–508.
- Matsunaga, T., Kawasaki, M., Yu, X., Tsujimura, N. and Nakamura, N. (1996) Chemiluminescence enzyme immunoassay using bacterial magnetic particles. *Anal Chem* **68**, 3551–3554.
- Mavrodi, D.V., Bonsall, R.F., Delaney, S.M., Soule, M.J., Phillips, G. and Thomashow, L.S. (2001) Functional analysis of genes for biosynthesis of pyocyanin and phenazine 1-carboxamide from *Pseudomonas aeruginosa* PAO1. *J Bacteriol* **183**, 6454–6465.
- Mériaux, S., Boucher, M., Marty, B., Lalatonne, Y., Prévèral, S., Motte, L., Lefèvre, C.T., Geffroy, F. *et al.* (2015) Magnetosomes, biogenic magnetic nanomaterials for brain molecular imaging with 17.2 T MRI scanner. *Adv Healthc Mater* **4**, 1076–1083.
- Murugan, K., Wei, J., Alsalhi, M.S., Nicoletti, M., Paulpandi, M., Samidoss, C.M., Dinesh, D., Chandramohan, B. *et al.* (2017) Magnetic nanoparticles are highly toxic to chloroquine-resistant *Plasmodium falciparum*, dengue virus (DEN-2), and their mosquito vectors. *Parasitol Res* **116**, 495–502.
- Reguera, G., McCarthy, K.D., Mehta, T., Nicoll, J.S., Tuominen, M.T. and Lovley, D.R. (2005) Extracellular electron transfer via microbial nanowires. *Nature* **435**, 1098–1101.
- Sacco, N.J., Bonetto, M.C. and Cortón, E. (2017) Isolation and characterization of a novel electrogenic bacterium, *Dietzia* sp. RNV-4. *PLoS ONE* **12**, e0169955.
- Sun, J., Duan, J., Dai, S., Ren, J., Guo, L., Jiang, W. and Li, Y. (2008) Preparation and anti-tumor efficiency evaluation of doxorubicin-loaded bacterial magnetosomes: magnetic nanoparticles as drug carriers isolated from *Magnetospirillum gryphiswaldense*. *Biotechnol Bioeng* **101**, 1313–1320.
- Tajer-Mohammad-Ghazvini, P., Kasra-Kermanshahi, R., Nozad-Golikand, R., Sadeghizadeh, M., Ghorbanzadeh-Mashkani, S. and Dabbagh, R. (2016) Cobalt separation by *Alphaproteobacterium* MTB-KTN90: magnetotactic bacteria in bioremediation. *Bioprocess Biosyst Eng* **39**, 1899–1911.
- Uebe, R. and Schüler, D. (2016) Magnetosome biogenesis in magnetotactic bacteria. *Nat Rev Microbiol* **14**, 621–637.
- Zhou, W., Zhang, Y., Ding, X., Liu, Y., Shen, F., Zhang, X., Deng, S., Xiao, H. *et al.* (2012) Magnetotactic bacteria: promising biosorbents for heavy metals. *Appl Microbiol Biotechnol* **95**, 1097–1104.
- Zhou, Y., Lisowski, W., Zhou, Y., Jern, N.W., Huang, K. and Fong, E. (2017) Genetic improvement of *Magnetospirillum gryphiswaldense* for enhanced biological removal of phosphate. *Biotechnol Lett* **39**, 1–6.

Supporting Information

Additional Supporting Information may be found in the online version of this article:

Table S1. Voltage measured from the uninoculated medium, MTB culture and purified magnetosomes respectively.

Table S2. Voltage measured from the dilution series of purified magnetosomes.